



**PNEUMATIC HAMMER
MARTEAU PIQUEUR
MARTILLO PICADORA**



MAC11D



Ref : MAC3DP04651 Indice : 04

ALLIANCE NORTH AMERICA, Inc.
1100 Hope Street
CYPRESS, CA 90630

Tel : 1-562-450-3570
Fax : 1-562-450-3570
e-mail : sales@anacorp.com

www.anacorp.com

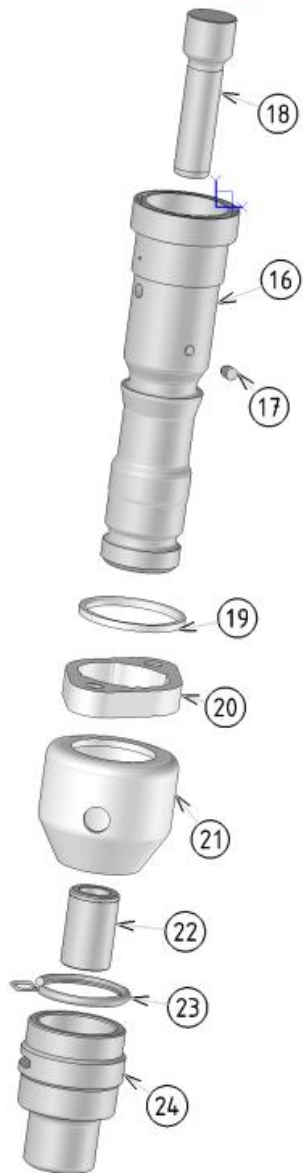
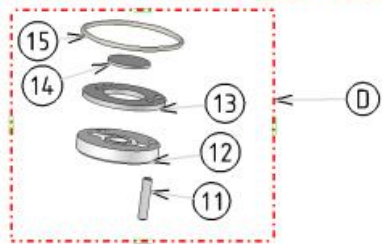
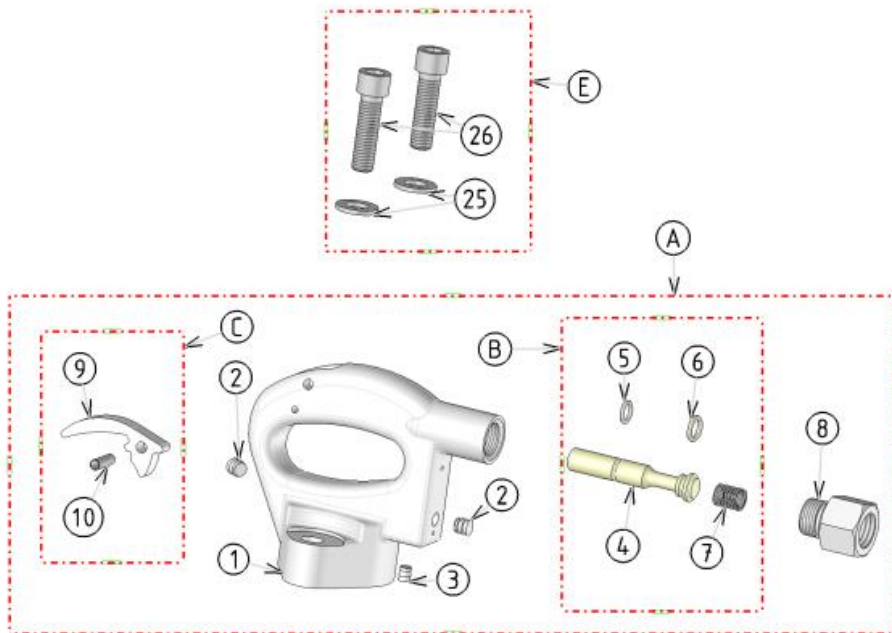

Repère	Référence	Nombre	Designation	Désignation	Designación
1	MAC3AP00837	1	- Handle	- Poignée	- Empuñadura
2	MAC3AP00838	2	- Plug	- Bouchon	- Tapa
3	MAC3AP00852	1	- Plug	- Bouchon	- Tapa
4	MAC3AP00821	1	- Valve	- Soupape	- Válvula
5	MAC3AS00839	1	- O-ring	- Joint	- Junta
6	MAC3AS00840	1	- O-ring	- Joint	- Junta
7	MAC3AP00841	1	- Spring	- Ressort	- Muelle
8	MAC3AP04692	1	- Nipple	- Mamelon	- Racor
9	MAC3AP04051	1	- Trigger	- Gâchette	- Gatillo
10	MAC3AS00844	1	- Pin	- Goupille	- Eje
11	MAC3AS00832	1	- Pin	- Goupille	- Eje
12	MAC3AP00818	1	- Seat	- Siège de frappe	- Silla de impacto
13	MAC3AP00834	1	- Shimplate	- Plaque dépaiseur	- Placa
14	MAC3AP00833	1	- Insert	- Pastille	- Pastilla
15	MAC3AS00835	1	- O-ring	- Joint	- Junta
16	MAC3AP03434	1	- Cylinder	- Cylindre	- Cilindro
17	MAC3AP00852	1	- Plug	- Bouchon	- Tapa
18	MAC3AP00828	1	- Piston	- Piston	- Pistón
19	MAC3AP00851	1	- Ring	- Bague	- Anillo
20	MAC3AP00850	1	- Flange	- Bride	- Brida
21	MAC3AP00825	1	- Muffler	- Atténuateur	- Mufla
22	MAC3AP03431	1	- Sleeve R 0.680	- Manchon R 17x60	- Mango R 0.680
	MAC3AP03428		- Sleeve RH 0.580	- Manchon RH 17x60	- Mango RH 0.580
23	MAC3AP03447	1	- Spring retainer lock	- Ressort décaleur	- Muelle Retenedor
24	MAC3AP03437	1	- Retainer	- Décaleur	- Retenedor
25	MAC3AS00849	2	- Washer	- Rondelle	- Arandela
26	MAC3AS00848	2	- Screw	- Vis	- Tornillo

KIT		Kit Pour Réparation	Repair Kit	Kit de Reparación
A	MAC3KS04999	- complete Handle	- Poignée complète	- Empuñadura completa
		1, 2(x2), 3, 4, 5, 6, 7, 8, 9, 10		
B	MAC3KS02137	- Valve	- Soupape	- Válvula
		4, 5, 6, 7		
C	MAC3KS04108	- Trigger	- Gâchette	- Gatillo
		9, 10		
D	MAC3KS02138	- Inlet valve	- Distribution	- Distribución
		11, 12, 13, 14, 15		
E	MAC3KS02142	- screws	- Vis poignée	- Tornillo
		25(x2), 26(x2)		
	MAC3KS02236	- Maintenance	- Maintenance	- Mantenimiento
		5, 6, 15, 19		

Shank size / Emmanchement / Enmangadura (mm / In)	Weight / Poids / Peso (Kg / Lb)	Length / Longueur / Longitud (mm / In)
R 17x60 - R 0.680	5 – 11	354 – 13.9
RH 17x60 - RH 0.580	5 – 11	354 – 13.9

FEATURE, CARACTERISTIQUES, CARACTERISTICA	
Bore / Alésage / Escariado (mm / In)	Ø27.8 - 1"3/32
Piston stroke / Course piston / Carrera del piston (mm / In)	60 - 2"3/8
Impact rate / Cadence de frappe / Golpes por minuto (cps/min / B.P.M.)	2800
Pressure / Pression / Presion (Bar / Psi)	6 - 87
Air consumption / Consommation / Consumo de aire (l/mm / CMF)	500 - 17.7
Hose / Flexible / Manguera (mm / In)	Ø13 - Ø1/2"