

AIRMAN

SG

INSTRUCTION MANUAL

ENGINE GENERATOR

SDG13LAX-8E1

[3-PHASE·1-PHASE
SIMULTANEOUS USE TYPE]

Please be sure to read this manual
before using this machine.

N

HOKUETSU INDUSTRIES CO., LTD.

Preface

Thank you for choosing "AIRMAN"

- ◆ Keep this manual at hand and refer to it as necessary.
- ◆ If this manual is missing or damaged, order a new copy from our office or your nearest dealer.
Make sure that the manual is included with the machine when it is handed over to another user.
- ◆ The contents of this manual may differ from the machine as a result of design changes. If anything is unclear or you want advisement, contact our office or your nearest dealer.

Table of Contents



1. Major Components	1-1
1.1 Internal Components	1- 1
2. Transportation and Installation	2-1
2.1 Transporting Machine	2- 1
2.2 Conditions of Installation	2- 2
2.3 Grounding	2- 5
2.4 Selecting Cable	2- 8
2.5 Fuel Pipe Selector Valve	2- 9
3. Operation	3-1
3.1 Control Panel	3- 1
3.2 Simultaneous usage of three-phase and single-phase power	3- 2
3.3 Connecting Loads	3- 3
3.4 Engine oil·Coolant·Fuel	3- 6
3.5 Before Starting the Unit	3- 8
3.6 Operating Procedure	3-14
3.7 Emergency Stop	3-18
4. Failure and Troubleshooting	4-1
4.1 Protection device	4- 1
4.2 Troubleshooting	4- 4
5. Periodic Inspection	5-1
5.1 Important Items at Periodic Inspection and Maintenance	5- 1
5.2 Maintenance Schedule	5- 2
5.3 Periodic Replacement Parts	5- 3
5.4 Maintenance Items	5- 4
6. Storage and Disposal	6-1
6.1 Preparation for Long-term Storage	6- 1
6.2 Disposal of Product	6- 1
7. Specifications	7-1
7.1 Specifications	7- 1
7.2 Outline drawing	7- 2
7.3 Generator Wiring Diagram	7- 4
7.4 Engine Wiring Diagram	7- 5
7.5 Piping Diagram	7- 6

Safety

This section explains safety precautions for operation, inspection, maintenance, installation, movement and transportation. Read these safety requirements carefully and fully understand the contents before starting the machine.

For better understanding of the precautions in this manual and on this machine, safety precautions are classified into "DANGER", "WARNING" and "CAUTION" messages with a warning symbol  marked, according to the degree of hazard.

When one of these messages is found, please take preventive measures for safety and carry out "SAFE OPERATION AND PROPER MAINTENANCE OF THE MACHINE".

 DANGER	DANGER indicates an imminently hazardous situation which, if not avoided, will result in death or serious injury.
 WARNING	WARNING indicates a potentially hazardous situation which, if not avoided, could result in death or serious injury.
 CAUTION	CAUTION indicates a potentially hazardous situation which, if not avoided, may result in minor or moderate injury. It may also be used to alert against unsafe practices.
IMPORTANT	IMPORTANT indicates important caution messages for the performance or durability of the machine, which has no concern to injury or accident of or to a human body.

This manual does not describe all safety items. We, therefore, advise you to pay special attention to all items (even though they may not be described in the manual) for your safety.

PROPOSITION 65 WARNING

 WARNING
<p>Breathing engine exhaust exposes you to chemicals known to the State of California to cause cancer and birth defects or other reproductive harm.</p> <ul style="list-style-type: none">● Always start and operate the engine in a well-ventilated area.● If in an enclosed area, vent the exhaust system.● Do not modify or tamper with the exhaust system.● Do not idle the engine except as necessary
<p>For more information, go to www.P65warnings.ca.gov/diesel</p>

Safety

- ◆ If you have any questions about the machine, please contact our office or your nearest dealer.
Be sure to have your machine's serial number to assist in providing the correct information for you.
A plate stamped with the model and serial number is attached to side of the machine.

ENGINE GENERATOR	
MODEL	<input type="text"/>
SER. NO.	<input type="text"/>
GEN. OUTPUT	<input type="text"/> kVA
VOLTAGE	<input type="text"/> V
FREQUENCY	<input type="text"/> Hz
POWER FACTOR	80% PHASE 3
RULE	JEM 1398
NET DRY MASS	<input type="text"/> kg
OPERATING MASS	<input type="text"/> kg
HOKUETSU INDUSTRIES CO., LTD.	
MADE IN JAPAN	

※ Each illustrated figure (Fig.) has a number (for instance, A040491) at the right bottom. This number is not a part number, but it is used only for our reference number.

A040491

Safety

[Safety Warning Labels]

Following labels are attached to the machine.

Keep them clean at all times. If they are damaged or missing, immediately place an order with your nearest dealer for replacement. Part numbers are indicated on the lower right corner of the label. Adhere a new one to the original location.

1

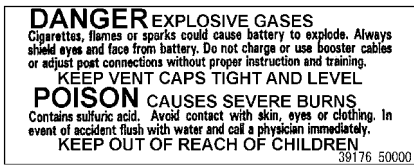

2

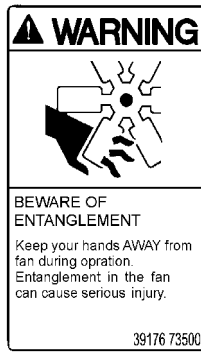

3

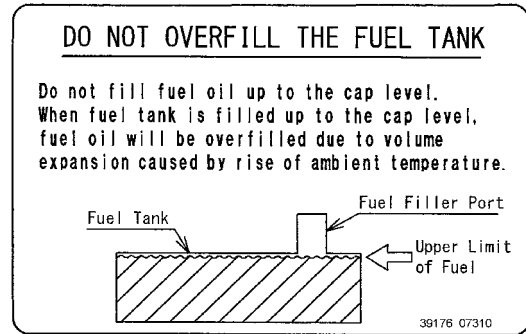

4

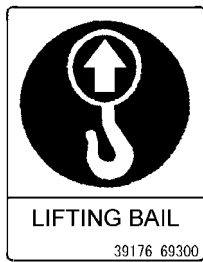

5



6

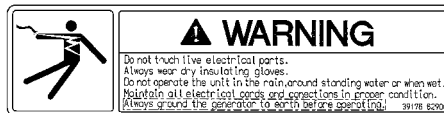

7



8

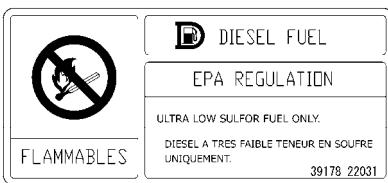

9



10

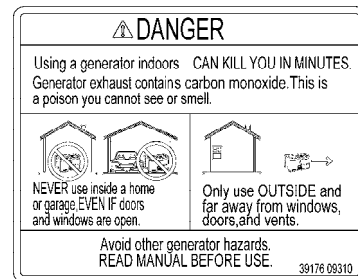

11

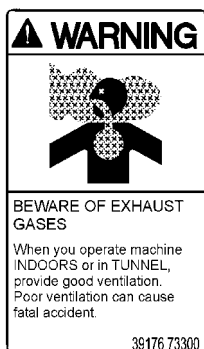

12

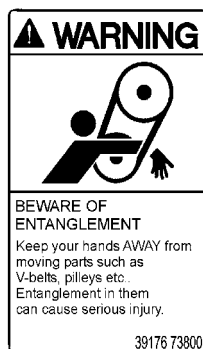

13



Safety

- The locations of the safety warning labels are as follows.

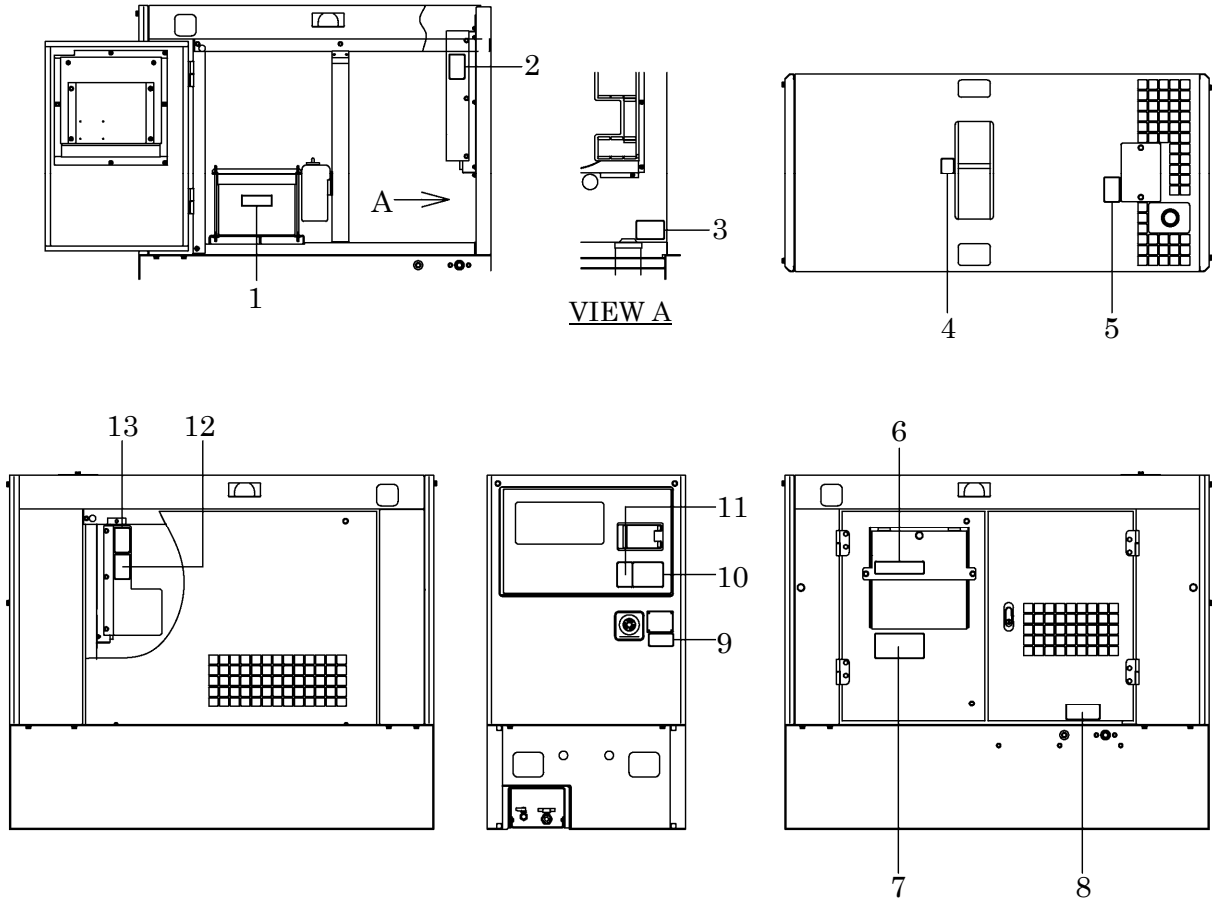

A180753-1

Safety

DANGER

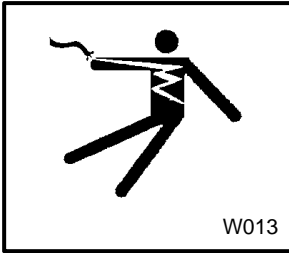

- Never touch the control panel during operation. Be aware that a voltage of several hundred volts is applied to the control panel.
- Be sure to stop the engine and turn control power switch OFF whenever the control panel has to be checked or operated. Disconnect the negative battery terminal during checking and maintenance.

WARNING

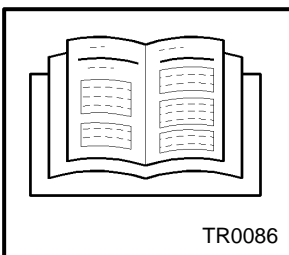

- Read each instruction plate which is displayed in the manual or on the machine carefully, understand its content and follow the indications thereof. Do not modify the machine without prior approval.
- The safety may be compromised, functions may be deteriorated, or machine life may be shortened.
- Never use the machine for the other purposes than power supply. Otherwise, serious accidents may occur.

WARNING

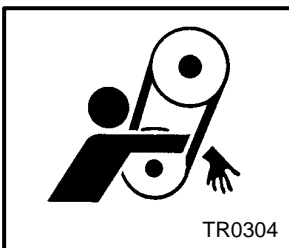

- Keep hands off from the rotating machinery or belts while running. It could cause serious injuries to hands.

WARNING



- When cleaning dust accumulated in devices such as filters, etc., with compressed air, wear safety glasses, etc. to protect your eyes

Safety

CAUTION

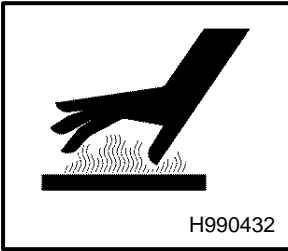

- Be sure to stop the engine and let the coolant water sufficiently cool down before draining it.
- If the drain valve is opened before the coolant water is cool enough, hot water could jet out, causing burns or scalding.

CAUTION

- When washing the machine, cover the control panel, generator and its electric parts to prevent them from being exposed to splashing water and avoid possible decrease in electrical insulation or other troubles to the machine.
- Dust, sand and dirt accumulated inside control panel could cause malfunction or difficulties with the instruments. Clean them using compressed air.

CAUTION

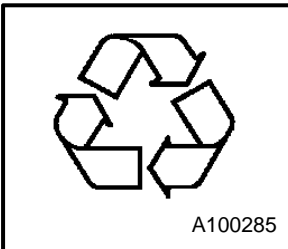

- Waste liquid from the machine contains harmful material. Do not discharge it onto the ground or into the river, lake or sea. Such material will pollute the environment.
- Be sure to use a container to hold waste liquid from the machine.
- Be sure to follow the designated regulations when disposing of oil, fuel, coolant (antifreeze), filter, battery or other harmful materials.

CAUTION

- The engine of this machine contains many electrical and electronic parts. Before welding, be sure to disconnect all electronic control equipment.
Failure to do so could result in equipment malfunction due to excessive current.

1. Major Components

1.1 Internal Components

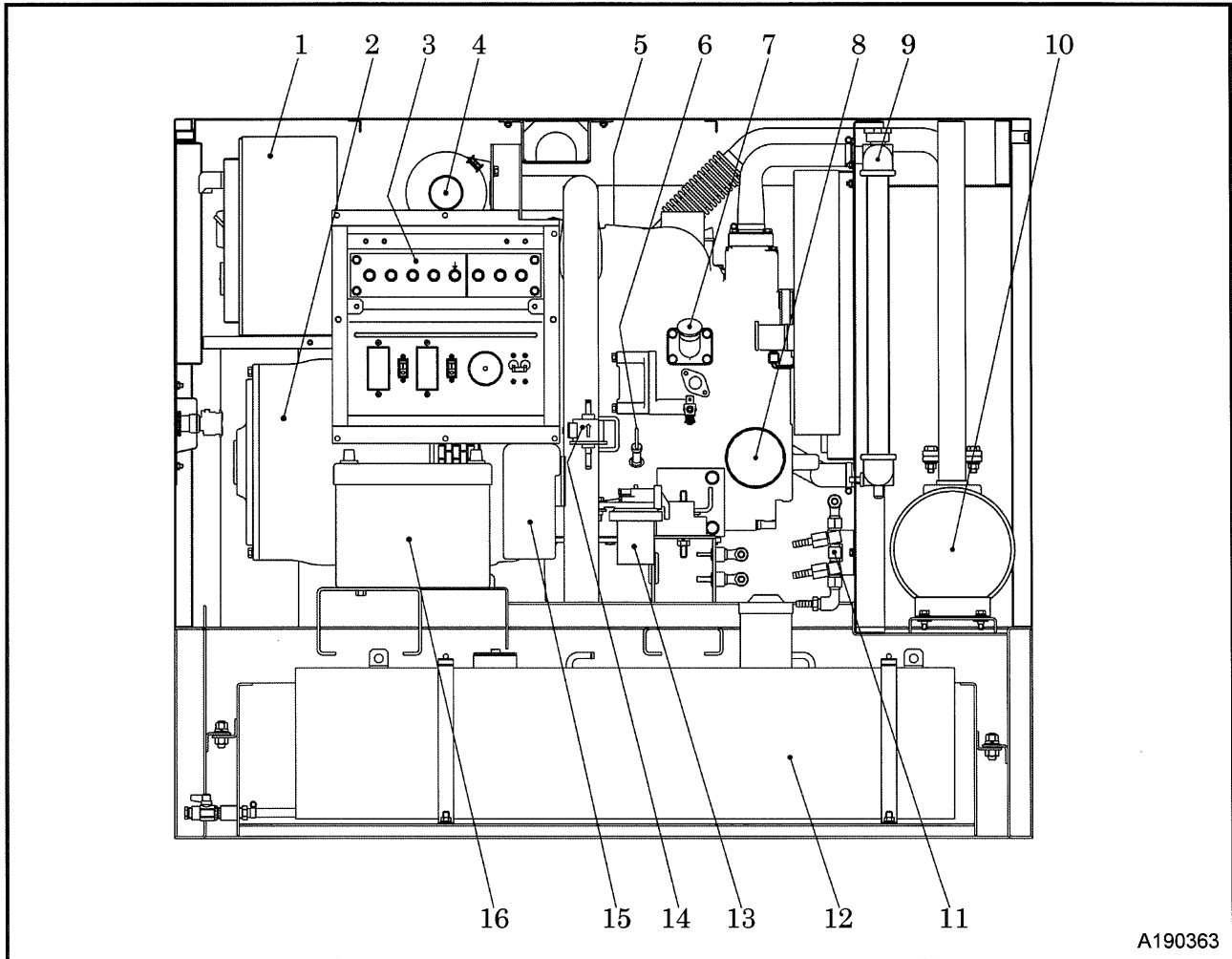

A190363

No.	Description	Function
1	Control Panel	Controlling device; various meters and controls.
2	Alternator	Generating AC power to be supplied.
3	Output terminals	Outlet port for AC power.
4	Air Filter	Filtering dust from intake air.
5	Engine	Driving the generator.
6	Engine Oil Level Gauge	Checking the engine oil level and contamination
7	Engine Oil Filler Port	Supplying and replenishing engine oil to engine.
8	Engine Oil Filter	Filtering engine oil in the system.
9	Radiator	Cooling the coolant for engine in the system
10	Exhaust Muffler	Silencing the noise caused before discharging the air.
11	Fuel Pipe Selector Valve	Switching to supply fuel from outer tank.
12	Fuel Tank	Storing fuel.
13	Fuel Filter	Filtering foreign matter and dust mixed in fuel.
14	Fuel air-bleeding electromagnetic pump	Automatically bleeding air from fuel pipes.
15	Reserve Tank	Checking coolant level and supplying it.
16	Battery	Electrically starting engine.

2. Transportation and Installation

2.1 Transporting Machine

When loading and unloading machine, be sure to use the lifting bail provided on the center of the machine top.

2.1.1 Lifting

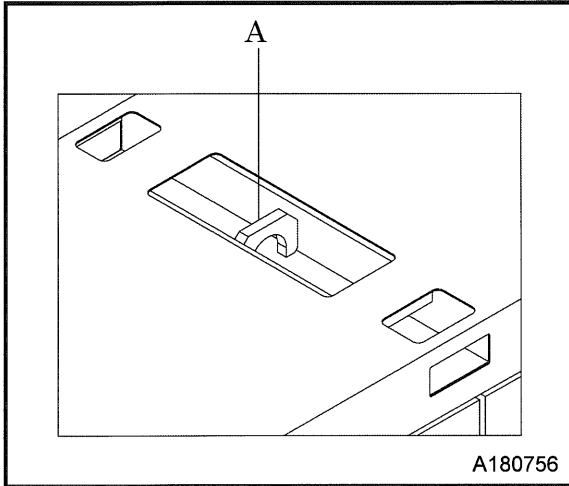

<Procedure>

1. Before lifting the unit up, make sure to check the lifting bail [A] for any cracks or loosened bolts.
 2. Connect the hook of the crane or shackle with lifting bail fitted at the top center of the unit, and make sure that there is no person standing around the unit. Then perform hoisting operation.
- Select an appropriate crane or truck by referring to the mass and dimensions mentioned in “Specifications”.
 - Only a qualified crane operator is allowed to operate a crane.



Transportation

- Never go underneath the unit when suspended because it is very dangerous.
- Do not lift the unit while it is running. Otherwise, a fatal or serious accident may occur.

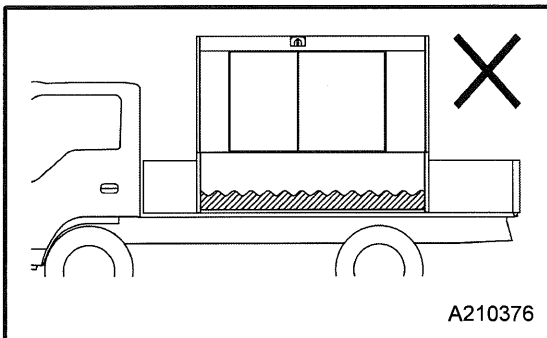
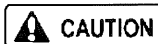

- Before transporting, check if there is condensate (fuel, oil and coolant) inside the oil fence, and if so drain it. (See 3.5.5)
- When transporting with condensate (fuel, oil and coolant) accumulated inside the oil fence, the condensate may flow out of the machine.

2. Transportation and Installation

2.2 Conditions of Installation

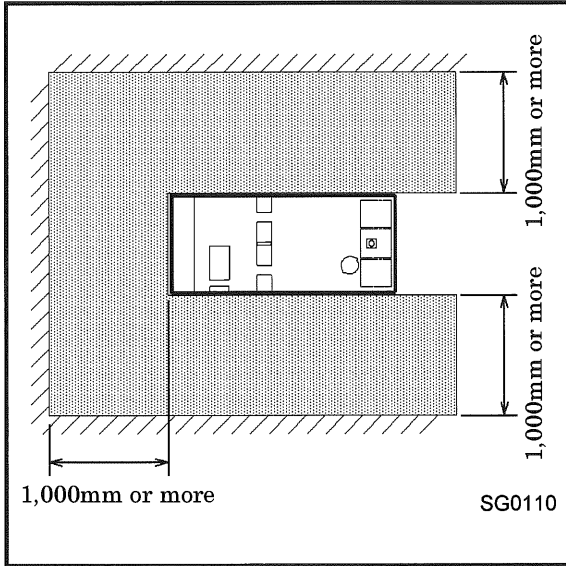

The machine has to be installed on a dry, firm, and level area.

- The machine should be operated in the following conditions:
 - Ambient temp: 5°F to 104°F (-15°C to 40°C)
 - Humidity: Less than 85%
 - Altitude: Lower than 1,000m above sea level.
- ✘ Using the machine outside the above conditions may cause serious failure.
- If more than two units are placed parallel in operation, keep enough distance so that exhaust air from the one does not affect the other one.
- Keep enough space around the unit for inspection and maintenance access.

WARNING

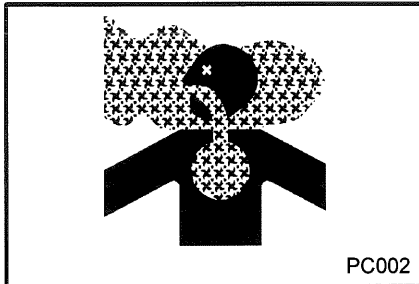

- Exhaust gas from the engine is poisonous, and it could cause casualties if inhaled. Avoid using the machine in an insufficiently ventilated building or a tunnel.
- Do not position the exhaust gas outlet in the direction of a person or a house.

WARNING

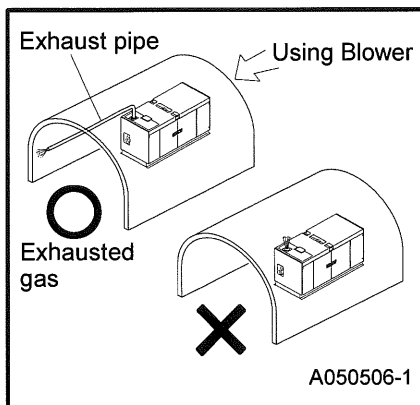

- In case that the unit is installed inside any tunnel, make sure to provide fresh air and ventilate it.
- In this case, make sure to extend the exhaust fume pipe outdoors, and also make sure to prevent any leak from any connection pipes.

2. Transportation and Installation

WARNING

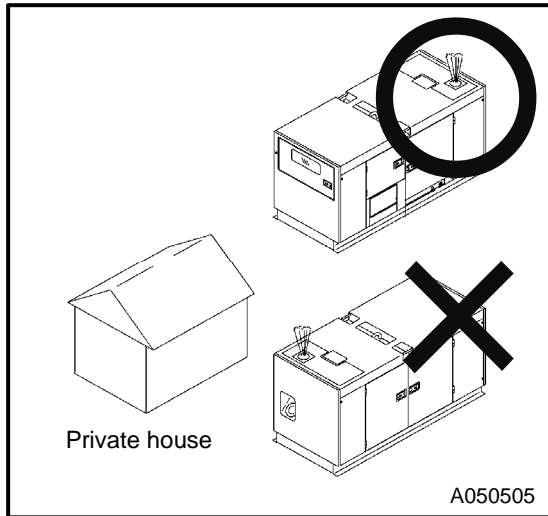

- Never locate the unit with the exhaust muffler facing any private house.
- As the exhaust gas from the engine is poisonous, never direct it to any other persons passing by.

WARNING

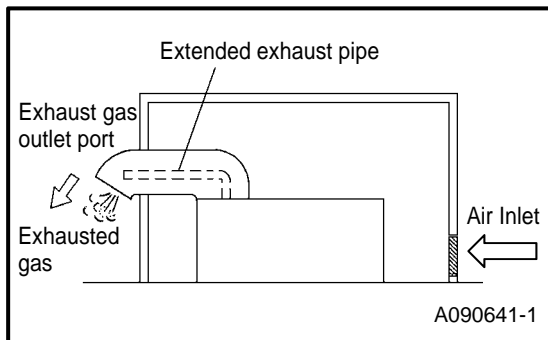

In case that the machine is installed indoors

- In case that the unit is installed indoors for operation, suction air port and exhaust fume outlet port should be provided for better air ventilation.
- Make sure to secure enough space in front of air suction port and to secure it after exhaust fume outlet port so that the engine will not get overheated.
- An exhaust pipe or the like should be provided at the exhaust outlet port so as to send exhaust fumes outdoors.
- The cooling air outlet port of radiator should have access to the outdoors through a duct or the like for air ventilation.

2. Transportation and Installation

CAUTION

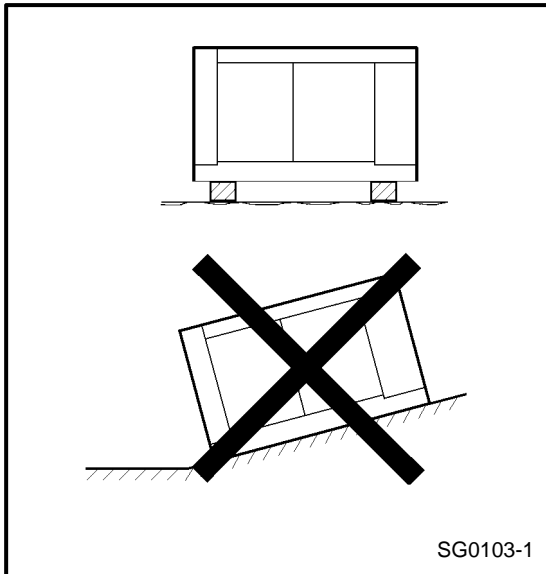

- The unit should be installed within 5 ° degree inclination.
- If installation site is not flat, put square bar under the unit so as to install it horizontally.
- Avoid installing the unit in a damp place or a place where water collects. Such an installation could cause electric shock.
- When installing the unit at the sea shore, make sure that it is not exposed directly to sea water because there is a risk of the change to the insulation resistance of the generator assembly or control panel inside. To request a model with measures against salt damage, please consult the nearest sales office.
- When installing the unit at a sandy place, make sure that exhaust from the generator or radiator does not blow the sand up in the air or into the machine.

CAUTION

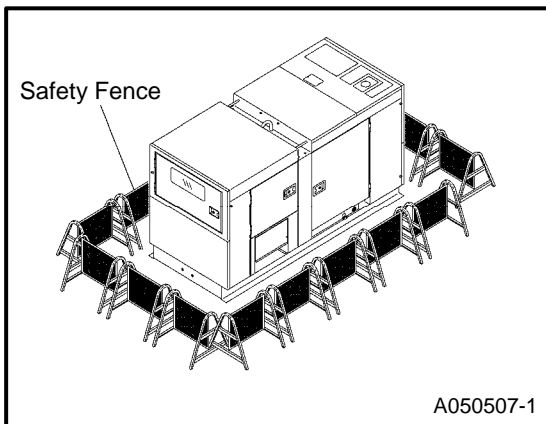

- In order to prevent from any persons other than those engaged in the job site from using or interacting with the machine, please prepare for safety fences around the unit.

2. Transportation and Installation

2.3 Grounding

2.3.1 Ground Terminal

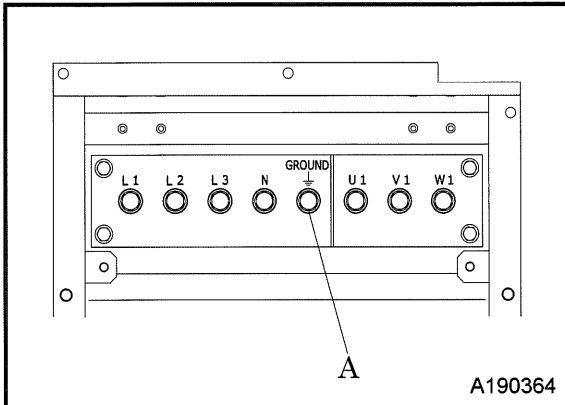

- The ground terminal [A] on the AC output terminal board is connected to the earth ground of this unit and to the earth terminal of each outlet.

※「V1」 is not neutral. Do not connect to ground.

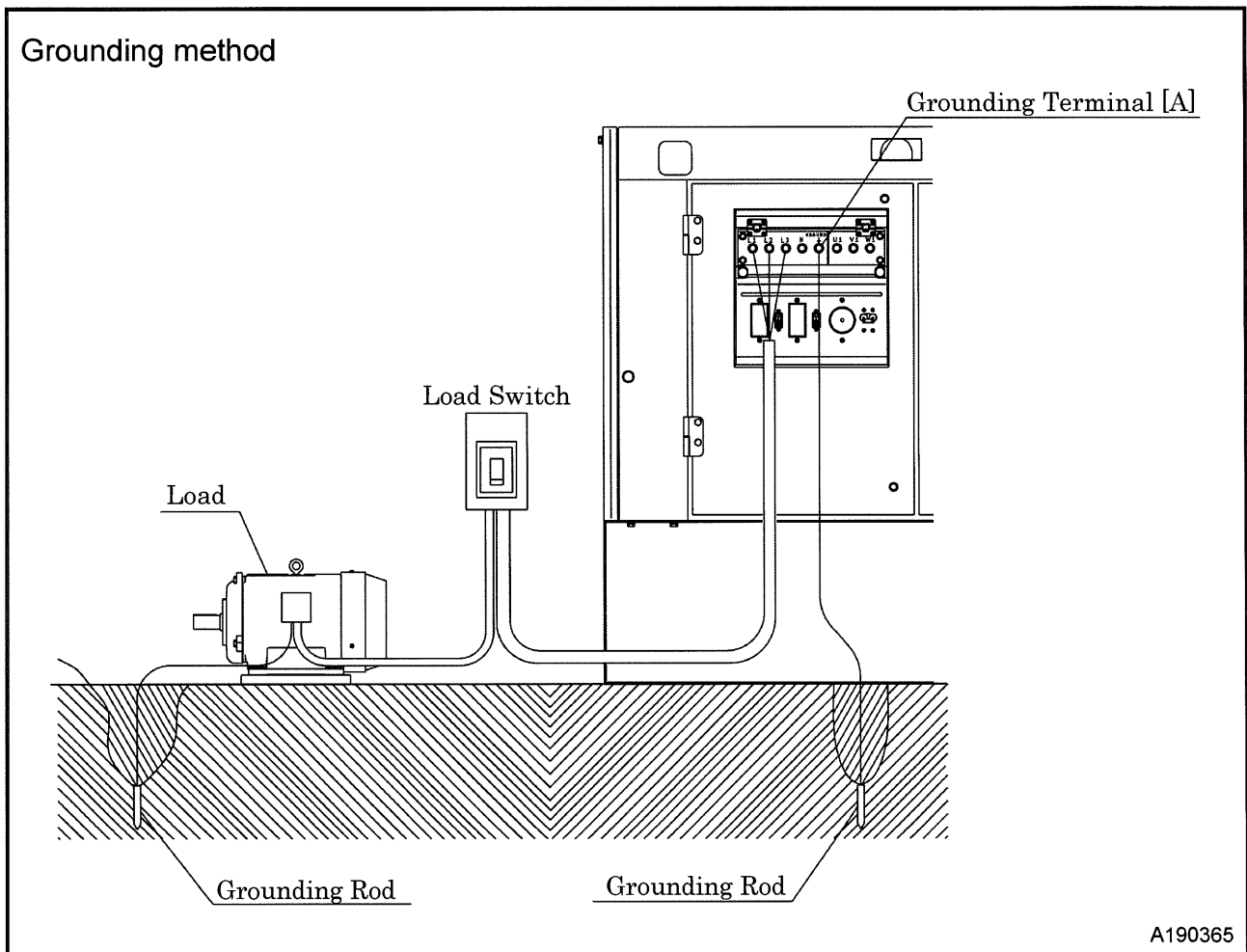

2.3.2 Grounding System

AIRMAN's generators have a system ground that connects generator frame components to the ground terminals in the AC output receptacles. The AC neutral wire (N) is connected to the system ground.

2. Transportation and Installation

2.3.3 GFCI Receptacles

- All of the 20 ampere 120 volt receptacles on the generator are protected by a GFCI (Ground-fault circuit interrupter) for protection against the hazards of ground fault currents. An example of ground-fault current is the current which would flow through a person who is using an appliance with faulty insulation and, at the same time, is in contact with an electrical ground such as a plumbing fixture, wet floor, or earth.
- The ground-fault circuit interrupter will not protect against short circuits or overloads. The circuit breaker in the control panel which supplies power to the circuit provides that protection.
- The ground-fault circuit interrupter can be identified by the TEST and RESET buttons. The receptacles on the GFCI can be tested with the TEST and RESET buttons.

TEST BUTTON: To test, depress the "TEST" button. (Power is turned off)

RESET BUTTON: To restore power, depress the "RESET" button.

- Perform this test monthly or every 250 hours operation, whichever comes first, in order to ensure proper operation of the GFCI receptacle. If the generator is stored outdoors, unprotected from the weather, test the GFCI receptacle before each use. Record your test on the GFCI test card provided on the control panel.

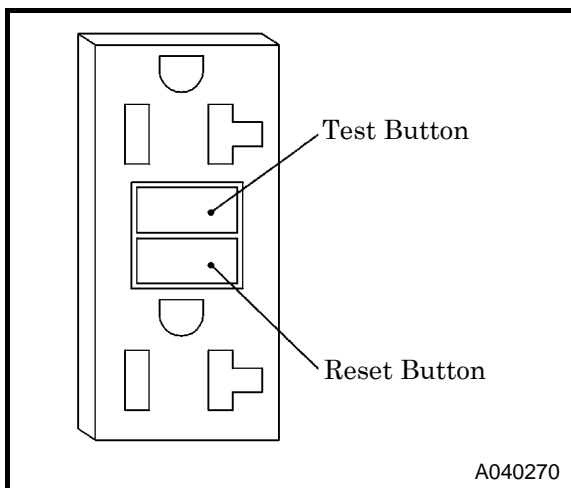

CAUTION

- Using the generator in rain, snow or near water can lead to death from electric shock. Keep the generator dry.

2. Transportation and Installation

2.3.4 Connections to a Building's Electrical System

Connections for standby power to a building's electrical system must be made by a qualified electrician. The connection must isolate the generator power from utility power and must comply with all applicable laws and electrical codes.

 **CAUTION**

- Improper connections to a building's electrical system can allow electrical current from the generator to backfeed into the utility lines. Such backfeed may electrocute utility company workers or others who are in contact with the lines during a power outage. Consult the utility company or a qualified electrician.
- Improper connections to a building's electrical system can allow electrical current from the utility company to backfeed into the generator. When utility power is restored, the generator may explode, burn, or cause a fire in the building's electrical system.

2. Transportation and Installation

2.4 Selecting Cable

- Select a cable with sufficient diameter by considering the permissible current on the cable and the distance from the generator to the load.
- If the current flowing to the load exceeds the permissible current of the cable, resultant overheating may burn the cable. Similarly, if the cable is too small in thickness to the length, the input voltage to the load will fall to cause the load input power to drop, as a result, the performance of the machine cannot be displayed.

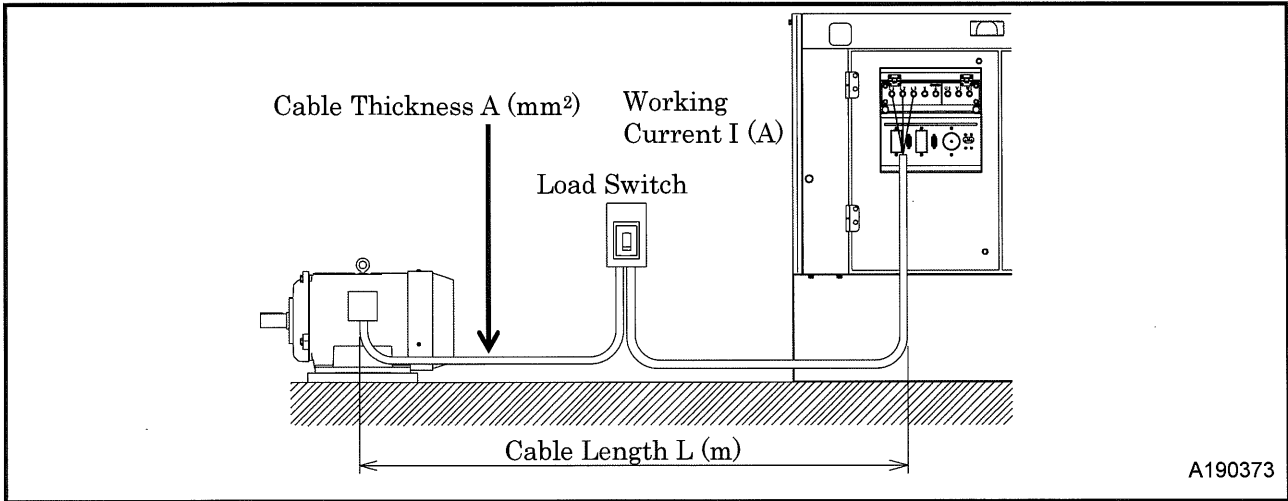

- Simplified formula to seek voltage drop or cross-sectional area of the cable from cable length and working current. Select such a cable length and thickness so that the voltage drop will remain within 5%.

Output system	Voltage drop	Cross-sectional area of the cable	e : Voltage drop (V) e' : Voltage drop between an outside line or one line of each phase, and a neutral line (V)
1-phase,2-wire type	$e = \frac{35.6 \times L \times I}{1,000 \times A}$	$A = \frac{35.6 \times L \times I}{1,000 \times e}$	A : Cable thickness (mm ²) L : Cable length (m) I : Working current (A)
3-phase,3-wire type	$e = \frac{30.8 \times L \times I}{1,000 \times A}$	$A = \frac{30.8 \times L \times I}{1,000 \times e}$	
1-phase,3-wire type and 3-phase,4-wire type	$e' = \frac{17.8 \times L \times I}{1,000 \times A}$	$A = \frac{17.8 \times L \times I}{1,000 \times e'}$	

- The following tables show the relations between the cable length and the cable thickness (nominal cross-sectional area) suited to the working current.

(Based on the condition that working voltage is 200 V, with voltage drop of 10V.)

Single-Conductor Cable

Unit: ft (m)

Length \ Current	165 (50)	246 (75)	328 (100)	410 (125)	492 (150)	656 (200)
50A	8	14	22	22	30	38

Three-Conductor Cable

Unit: ft (m)

Length \ Current	165 (50)	246 (75)	328 (100)	410 (125)	492 (150)	656 (200)
50A	14	14	22	22	30	38

2. Transportation and Installation

2.5 Fuel Pipe Selector Valve

2.5.1 Overview

This valve is designed to feed fuel directly from an external fuel tank or from the installed fuel tank as described below.

2.5.2 Operation method

<Procedure>

1. Machine is delivered from factory with fuel line piping and selector valves built in as shown in the following Fig.1. When operating a machine, using installed fuel tank, run the machine with the fuel line piping and the handles of selector valves factory-arranged.
2. When using a separate storage tank, remove the plug fitted at the connections to the separator tank and make piping as shown in Fig.2. And then turn the handles of the selector valve as shown in Fig.2.
3. When removing the piping connection, make sure to return the handles to the original positions shown in Fig.1 and install the plugs.

2.5.3 Installation of Separate Storage Fuel tank and piping method

<Procedure>

1. Use oil resistant hoses with an inside diameter of 8mm to 10mm.
2. Install the fuel tank so that the fuel level of the tank is between 0 and 2.5m high from the machine installation level.
3. In order to avoid suction of water and sediment together, install the suction pipe so that the inlet port of suction pipe may be kept between 15mm and 20mm higher than the bottom line of the tank. Also install the outlet port of the return pipe inside the tank. (See Fig.2·A)
4. When refilling fuel in the tank, take great care to not allow water and sediment in.

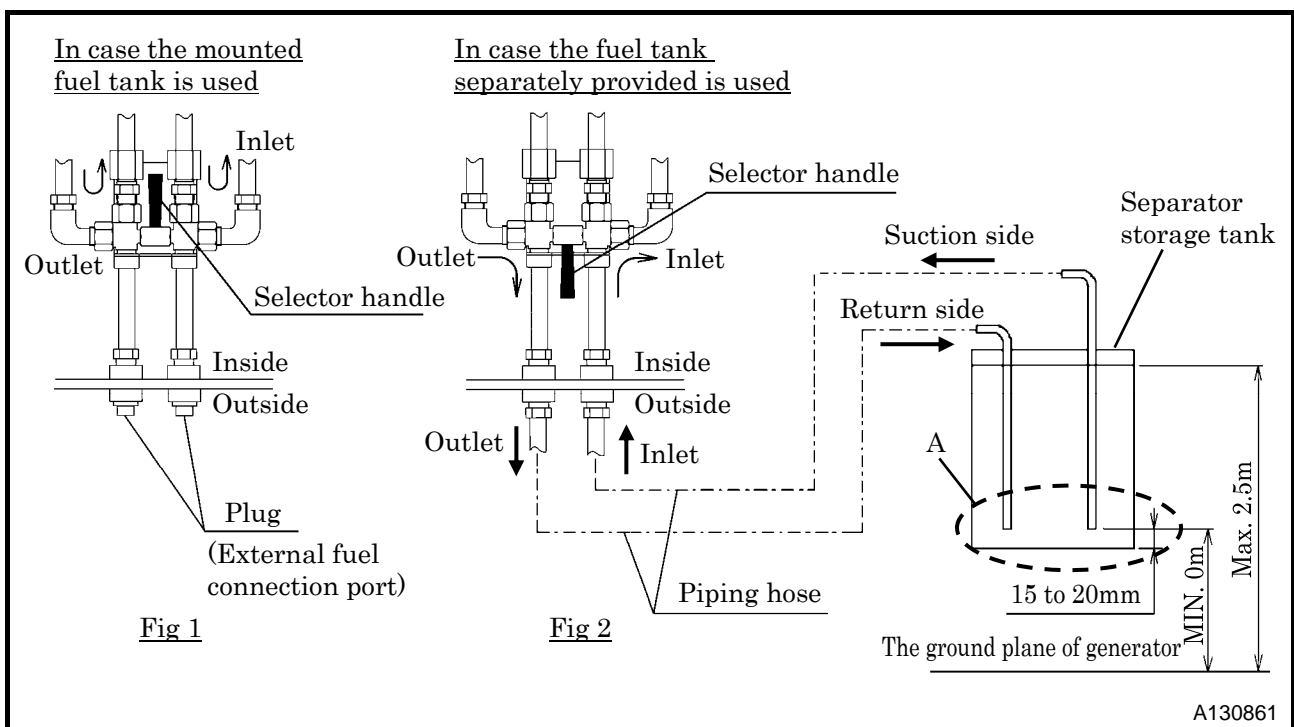

2. Transportation and Installation

 CAUTION

- Always keep watching the fuel feeding conditions while feeding fuel from the external fuel storage tank.
- Make sure to change the handles of the selector valves to the predetermined positions. If you make a mistake in turning the handles, it can burst the fuel pipe and cause overflowing. It could lead to a serious accident.
- Do not use excessive force to the selector valve handle. It could cause damage or fuel leakage.

3. Operation

3.1 Control Panel

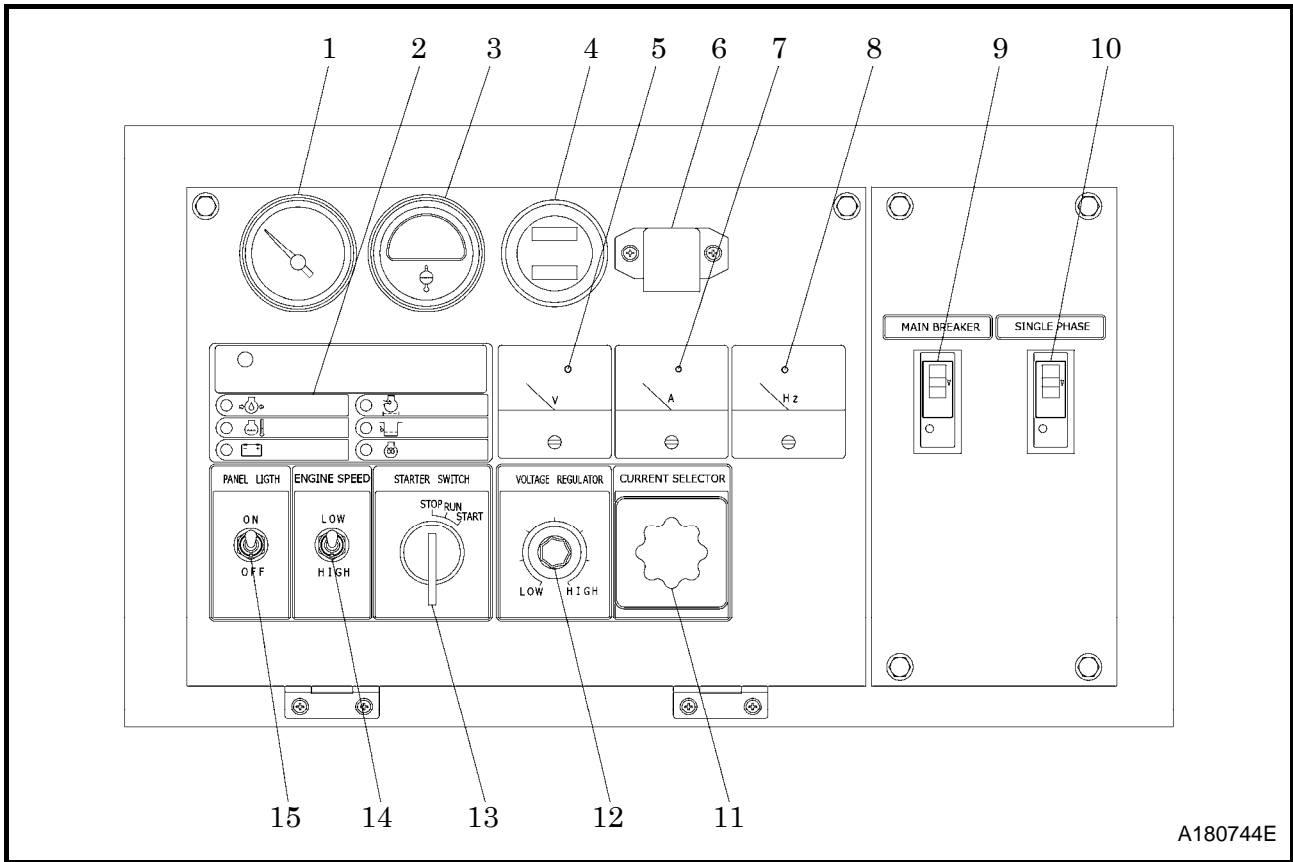

A180744E

- | | |
|--|----------------------------------|
| 1. Voltmeter | 10. Single-phase circuit breaker |
| 2. Monitor lamp (for details, See 4.1.1) | 11. Current selector |
| 3. Water temperature gauge | 12. Voltage regulator |
| 4. Fuelmeter with hourmeter | 13. Starter switch |
| 5. Voltmeter | 14. Engine Speed selector switch |
| 6. Panel light | 15. Panel light switch |
| 7. Ammeter | |
| 8. Frequency meter | |
| 9. Three-phase circuit breaker | |

3. Operation

3.2 Simultaneous usage of three-phase and single-phase power

This generator is capable of simultaneously outputting three-phase and single-phase power with no need to switch output settings.

[3Φ, 4 wire and 1Φ, 3 wire setup for simultaneous use]

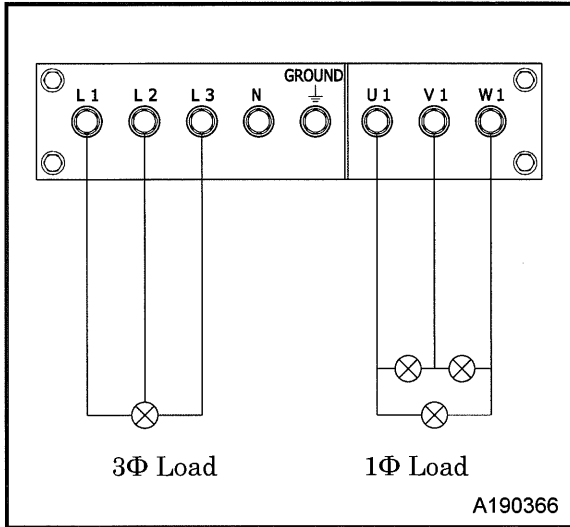

- Make sure that the combined three-phase and single-phase output does not exceed the total allowable current for the unit (see sample table below).

Output	Allowable current during simultaneous use(A)			
	0	10	20	30
3Φ, 4 wire (240V)	0	10	20	30
1Φ, 3 wire (240V)	40	28	14	0

- ※ Refer to section 3.3 for instructions on how to connect three-phase or single-phase loads.

[Checking current during simultaneous use]

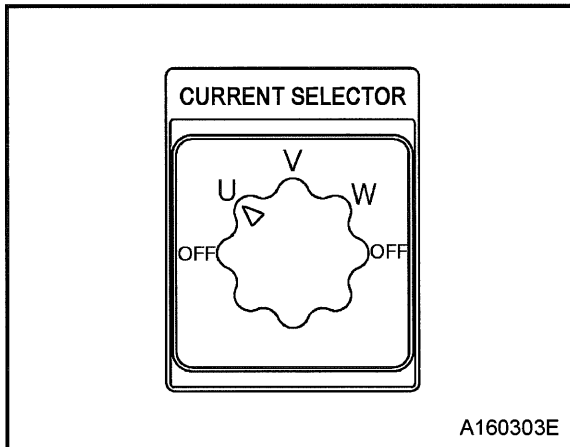

- Using the ammeter, check to make sure that each phase is within limits. See table below for the required current selector setting for each phase to be tested.

Current Selector	Phases being measured	
	3Φ, 4 wire	1Φ, 3 wire
U	L1	U1
V	L2	-
W	L3	W1

3. Operation

3.3 Connecting Loads

Select a cable with sufficient diameter by considering the load capacity and the distance from the generator to the load. Use terminals for connection and securely fasten them. **(See 2.4)**

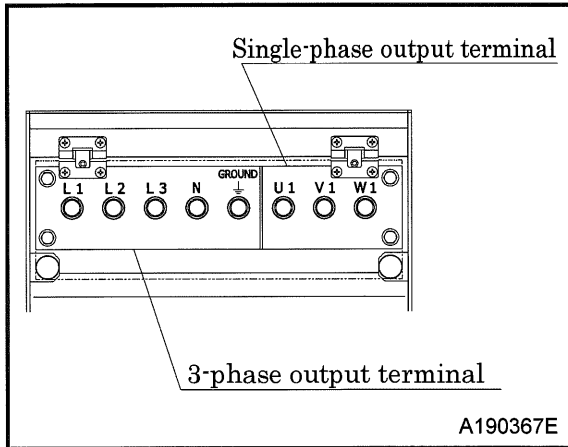

- After checking phase number and voltage of the load, make sure to connect them correctly.

---Terminal Size---

3-phase output (L1·L2·L3·N·G)	M8
Single-phase output (U1·V1·W1)	M8

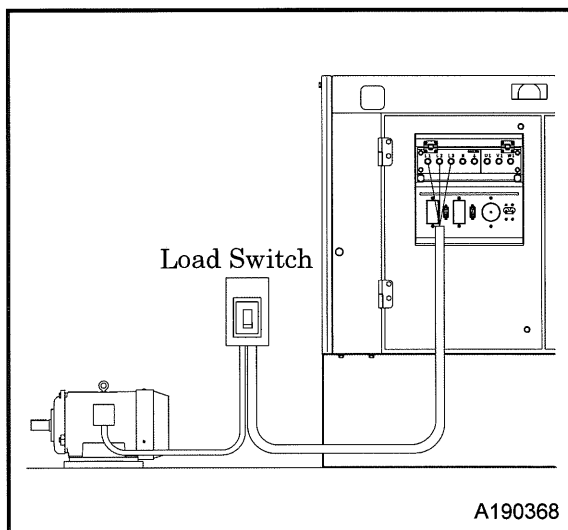

- Install a load switch between the output terminal and the load to switch on/off the load. Do not switch the load on/off directly by the circuit-breaker of the generator. It could cause damage to the circuit-breaker.
- Connect the connecting cable to the load so that the output terminals should not touch each other.

WARNING

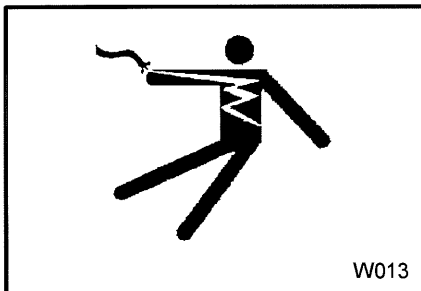

- When removing or connecting a connecting cable for changing load, be sure to switch OFF the circuit breaker, and then carry out a work. The operator must keep the key during operation.
- For a connecting cable to load, do not use a cable with damaged sheath nor an inappropriate insulation cable to the voltage. Secure connections between each cable terminal and input/output terminal. Otherwise, it may be slackened during operation and may cause a fire or an electric shock accident.

3. Operation

3.3.1 Auxiliary AC Power

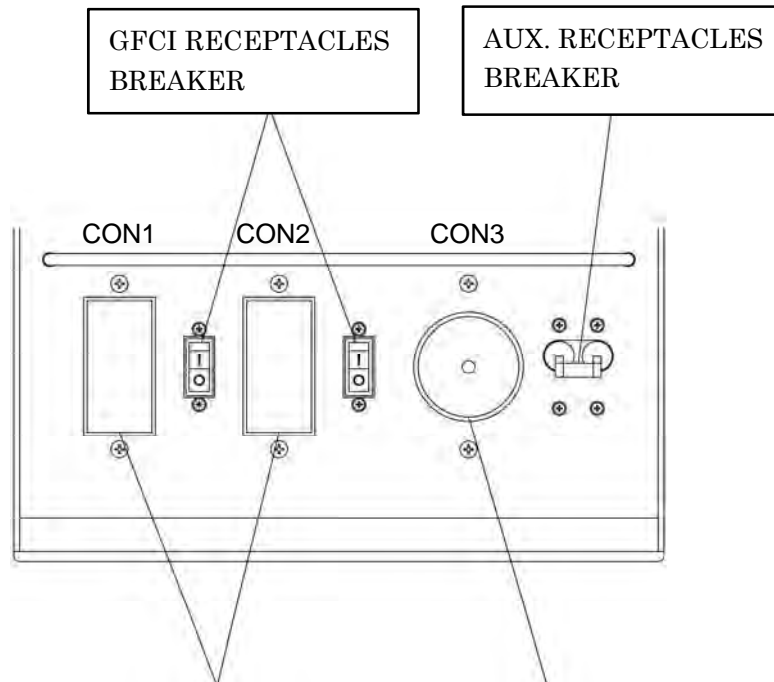

GFCI RECEPTACLES.
120V 20AMPS

AUX.RECECTACLES
240/120V 30AMPS

A180748

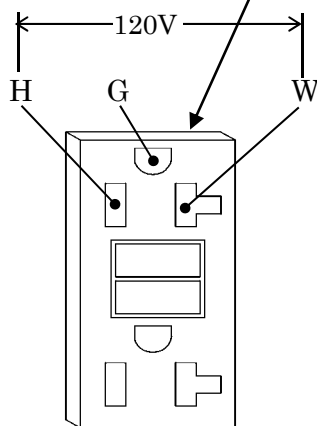

A040270

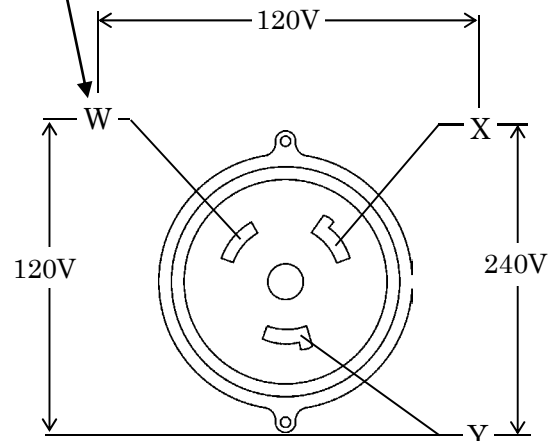

A040271

<How to use GFCI Receptacles>

1Φ/120V power from GFCI receptacles is available.

<Procedure>

1. Start the generator unit and turn the main breaker [ON] on the control panel.
2. Turn the receptacle breaker of output terminal [ON].

<How to use aux. receptacles>

1Φ 240/120V power is available from the auxiliary receptacles.

<Procedure>

1. Start the generator unit and turn the main breaker [ON] on the control panel.
2. Turn the receptacle breaker of output terminal [ON].

3. Operation

3.3.2 Connecting a single-phase load (1Φ, 3 wire / receptacles)

The table below shows the maximum load for each output terminal.

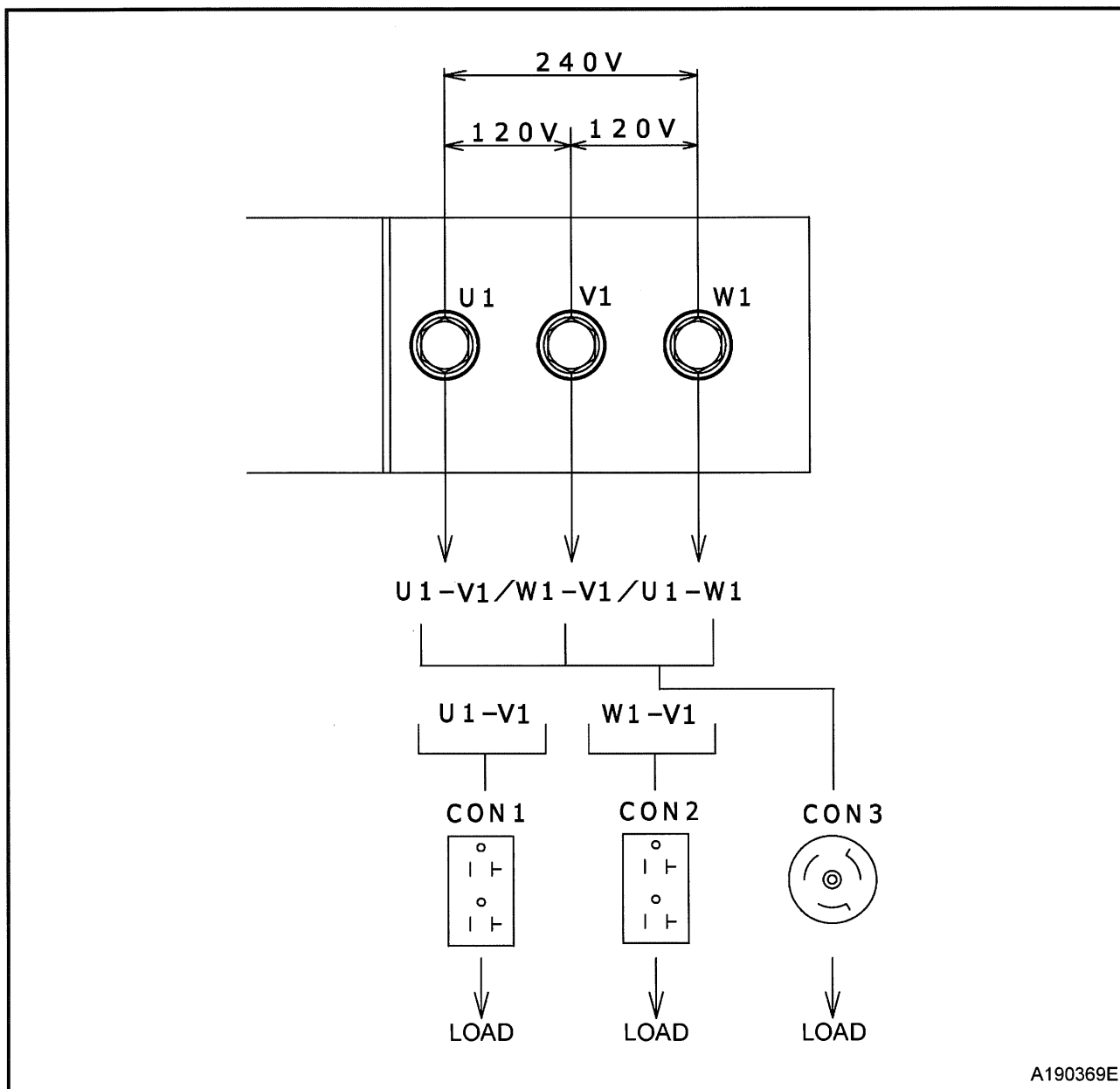

- The maximum rated output (kVA) of each terminal/receptacle is shown in the table below. Be sure not to connect loads exceeding the maximum rated output.

1Φ, 3 wire Terminal		1Φ 120V Receptacle		1Φ 120/240V Receptacle	Total Load Capacity
		CON1	CON2	CON3	
U1-W1	9.6	2.4	2.4	7.2	9.6
U1-V1	4.8				4.8
W1-V1	4.8				4.8

3. Operation

3.4 Engine Oil · Coolant · Fuel

3.4.1 Engine Oil

Use engine oil recommended below. Be sure to use CF class or higher engine oil or superior class. (Using engine oil with poor quality may shorten the life of the engine).

Classification	API service classification CF class or higher
Viscosity	SAE10W-30 (as ex-factory)

IMPORTANT

- Viscosity of engine oil greatly affects starting, performance, and oil consumption of the engine, as well as wear of the moving parts. Choose appropriate oil based upon the table below according to the outside air temperature.

Ambient temperature range and oil viscosity (SAE)

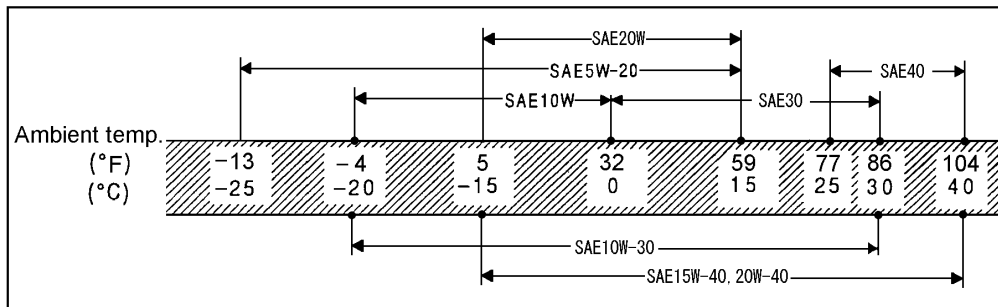

A180160E

- Do not mix oils. If two or more different brands of oil are mixed, its performance can be deteriorated.
- When the machine is operating under a light load (20% or less) for a prolonged period of time, check the viscosity of the engine oil and other fluids, and replace oil early using about half of the regular replacement time as a guide.
- Unit is delivered ex. factory, filled with engine oil recommended by engine manufacturer
- Dispose of oil in accordance with local laws and regulations.

3. Operation

3.4.2 Coolant

Coolant freezing could cause cracks of cylinder and radiator. Be sure to always use mixture of LLC (antifreeze) and soft water (like tap water) of good quality.

IMPORTANT

- When water with dirt, sand, or dust, or hard water such as well water (ground water) is used, deposits can form inside the radiator or on the cylinder head and resulting in engine overheat from poor coolant flow.
- Adjust mixing ratio of coolant according to the temperature. (55% volume coolant is filled when the unit is shipped from factory.) Use coolant within the range of its mixing ratio between 60%. (If LLC (antifreeze) exceeds more than 60%, it may decrease its antifreezing effect.)

Mixing ratio of LLC (antifreeze) (reference)

Outside temperature (°F)	5	-4	-13	-22	-31	-40	-49
Outside temperature (°C)	-15	-20	-25	-30	-35	-40	-45
Mixing ratio (%)	30	35	40	45	50	55	60

- Dispose of LLC (Antifreeze) in accordance with local laws and regulations.

3.4.3 Fuel

IMPORTANT

- Never use fuel with sulfur content greater than 0.0015% (15 ppm).
- Use only ultra-low sulfur fuel.
- Dispose of fuel in accordance with local laws and regulations.

CAUTION

- Diesel fuel is required to meet the following conditions.
 - Free from even minute dust particles
 - High optimum viscosity
 - High cetane number (more than 45)
 - High fluidity even at low temperature
 - Low carbon residue content

3. Operation

3.5 Before Starting the Unit

Be sure to check the unit before operation. When any abnormality is found, be sure to repair it before starting. Be sure to make daily check before operation. If the unit is operated without prior check and without noticing its abnormality, such operation could cause seizure of components or may even cause fire.

3.5.1 Check Engine Oil Level

The unit should be level before the checking oil level. When you check oil level after you have started operation, wait more than 10 minutes after stopping the engine before checking the oil level.

<Procedures>

1. Pull out the engine oil level gauge and wipe it with a clean cloth.
 2. Re-insert the engine oil level gauge fully and pull it out again. If the gauge shows the oil level between LOW and FULL limits, it is normal.
 3. When the oil level is below its LOW, add engine oil from engine oil filler port [A].
- If the oil is found to be dirty or contaminated, change the oil. **(See 5.4.1)**
 - To prevent engine output reduction when oil level is too high, do not put more oil in than FULL.

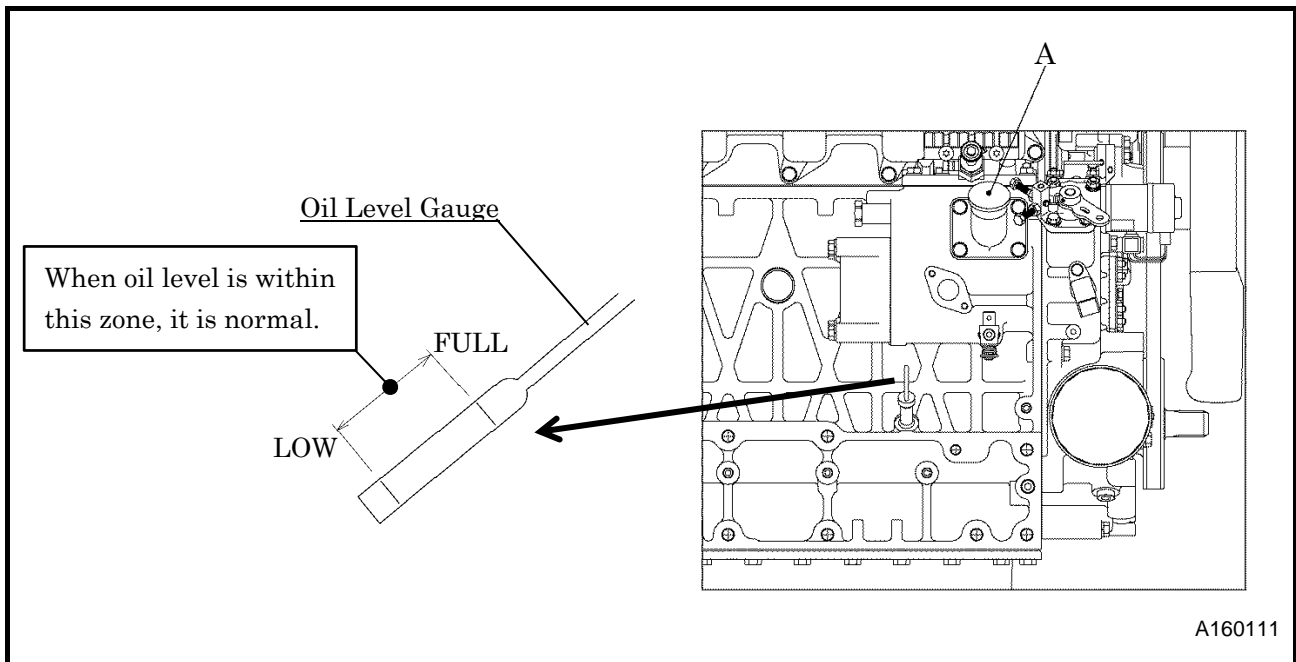

3. Operation

3.5.2 Check Coolant Level

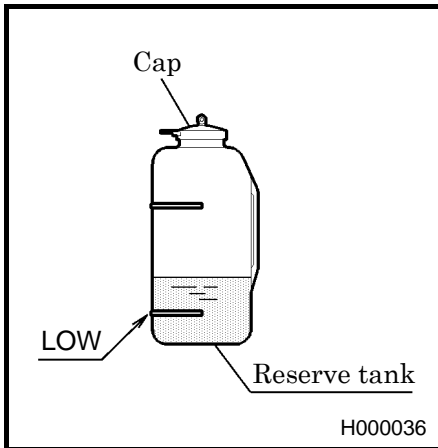

- Check the coolant level in the surge tank. If it is lower than the limit, open the cap and refill the coolant. (Level must be kept above LOW.)
- If the coolant in the surge tank is exceedingly low or empty, remove the radiator cap and check the amount of coolant in the radiator. Refill coolant within the radiator and surge tank. (See 5.4.20)

CAUTION

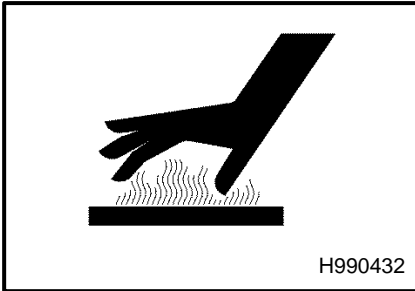

- When removing the radiator cap, lightly turn it and release the internal pressure without completely opening it once the first stage lock is released. After confirming that the internal pressure has been released, turn it off while pushing in until the second stage lock is released. If this procedure is neglected, its inner pressure can blow off the radiator cap, and steam jetting out of the radiator could cause scalding.

IMPORTANT

- Do not operate the machine without sufficient coolant. Insufficient coolant can cause air bubbles to form and damage the radiator.

3. Operation

3.5.3 Check Fuel

Before starting operation, make sure to check the level of residual fuel so that fuel shortage during operation can be avoided. If necessary, drain condensate accumulated at the bottom of the fuel tank.

- Refilling fuel tank should be done in an outdoor well-ventilated place.
- **Do not fill fuel up to the filler level.**

When fuel tank is filled up to the filler level, the expansion volume of the tank is too small and could lead to problems with fuel flow and containment. Furthermore, fuel may spill from the fuel tank due to vibration caused during movement or transportation of the unit.

CAUTION



D004

- Do not, under any circumstance, bring lit cigarettes and/or matches to the fuel.
- The fuel is extremely flammable and dangerous. Be careful of fire because the fuel is very likely to catch fire.
- Refuel only after stopping the engine, and never leave open fuel can near the machine. Do not spill. It could cause a fire. When it is spilled, wipe it up completely.

3.5.4 Check Fuel Filter Drain

If the red float [A] is raised above its base, drain any condensate accumulated in the fuel filter.

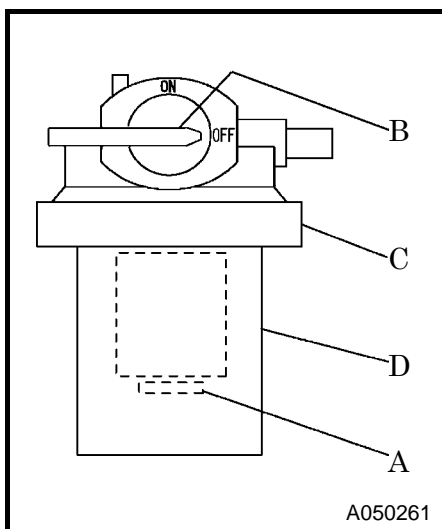

<Procedure>

1. Place the lever [B] of fuel filter to [OFF] position.
2. Loosen the ring nut [C] and remove the cup [D].
 - Carefully handle the cup because it is filled with fuel, and never spill the fuel inside the machine.
3. After draining the water collected inside, clean the cup [D] and then install it.
4. Turn the lever [B] to [ON] position and fill the cup with fuel. Then bleed air. **(See 3.6.6)**
 - Drain the condensate into a container, and then dispose of condensate according to the designated regulations.

3. Operation

3.5.5 Check Oil Fence Drain

Drain port in oil fence is provided on the side of oil fence.

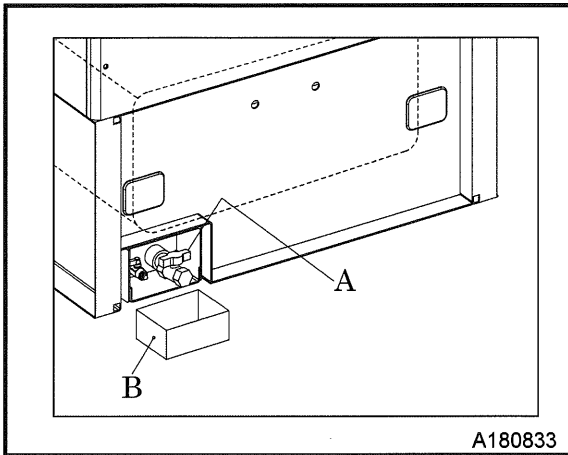

- Open drain valve [A] to drain out the condensate in the oil fence.
- After making sure that all condensate is completely drained out, close drain valve.
- Drain the condensate into a container [B], and then dispose of condensate according to the designated regulations.

CAUTION

- If the drain contains fuel, oil, or coolant, inspect each part for leaks.

3.5.6 Check Interior

Periodically check the inside of the generator for dust and flammables

CAUTION

- Please wear personal protective equipment, such as a helmet, safety glasses, earplugs, safety shoes, gloves, and a mask as appropriate to the work environment.
- Periodically check the inside of the generator for dust and flammables. When any flammables such as chips of wood, dead leaves (dry leaves) and waste paper are left near heated exhaust muffler and heated exhaust pipe, all of them should be removed.
- Keep a fire extinguisher available by the machine in case of unexpected fire.
- It is advisable to have a list of phone numbers of doctors, ambulance and the fire department available in case of emergency.

3.5.7 Clean Instruments In Control Panel

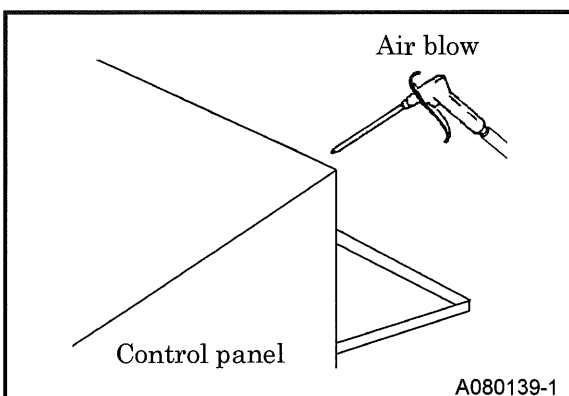

- Before starting operation, open control panel and check each breaker, terminal plate and each controller for any dust, sand and dirt accumulated.
- If the machine is operated with dust, sand, or dirt in the instrumentation, it could cause malfunction or damage. When necessary, clean the inside of the panel with compressed air. Wear protective eyewear when cleaning.

3. Operation

3.5.8 Check Belt Tension

Adjust the belt by the following procedure:

Unfasten the mounting bolts of the alternator to adjust the alternator belt.

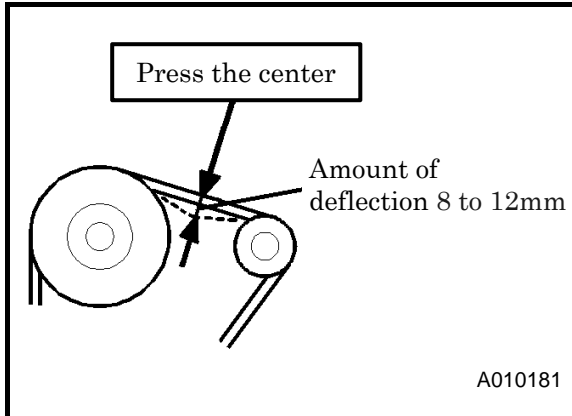

<Procedure>

1. Visually check there are no cracks or wear or other damage to the belt.
2. Belt tension is adjusted by loosening the alternator mounting bolts and nuts. While pressing the center of the belt slightly, adjust belt tension by loosening fitting bolt so the amount of deflection is between 8 to 12mm (98.1 N).
3. If there is any oil or coolant on the belt, wipe it off completely during service.

WARNING

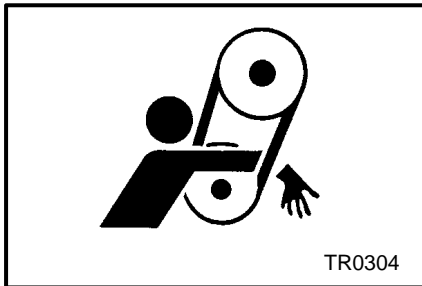

- Be sure to stop the engine and remove the starter key whenever the tension of the belt is to be adjusted.
- Remove the negative (-) side cable from the battery.
- If the machine is running, it might catch the operator's hand into the belts, and this could cause a serious injury.
- Be sure to stop the engine and remove the starter key whenever the tension of the belt is to be adjusted.
- If the machine is running, it might catch the operator's hand into the belts, and this could cause a serious injury.

IMPORTANT

- Over-tensioning of the belt leads to shaft breakage and reduced bearing life. If it is too loose, belt slippage may lead to premature breakage of the belt or damage to the machine due to overheating.

3. Operation

3.5.9 Check Thermo Label of Alternator

Thermo-label on the stator irreversibly changes its color from white to brown by reaching or exceeding 212°F (100°C), that signalize overload during operation. Do not overload the generator.

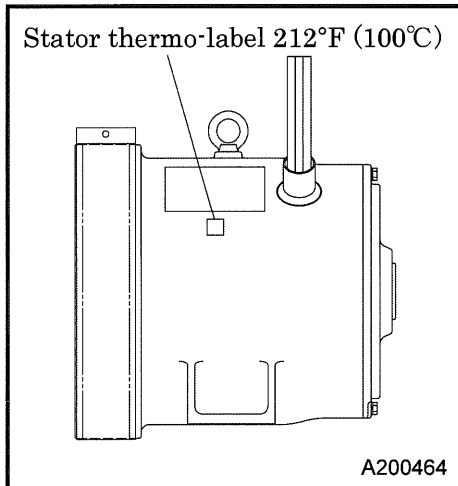

- Remove the trash and dust from the generator inside by compressed air blowing.
- Replace thermo-label, if it have changed the color once.
- When replacing, contact your nearest dealer.

3.5.10 Check Doors

Pull the handle forward to open the door. Be sure to close the door tightly so that its latch is firmly caught.

WARNING

PK0028

- Keep the door closed and locked while running the machine.
- When opening the door unavoidably, be careful not to touch the moving s and hot parts. Scalding or serious injury could result.

3. Operation

3.6 Operating Procedure

Make sure that all enclosure doors are closed before starting.

3.6.1 Operating Procedure

To start, please follow the procedure below.

<Engine starts>

1. Make sure that Three-phase circuit breaker [A] and Single-phase circuit breaker [B] are [OFF].
2. Turn the starter switch [C] to [RUN] position, and the glow lamp [D] goes on.
(If water temperature is high, glow lamp will not go on.)
3. Immediately after the glow lamp distinguishes, turn starter switch [C] fully to the right to start engine.
4. Once the engine has started up, leave the engine running to warm up for approximately 5 minutes.
(If operates machine for warming-up at cold time, turn the Engine Speed selector switch [E] to "HIGH" position after warming-up operation.)

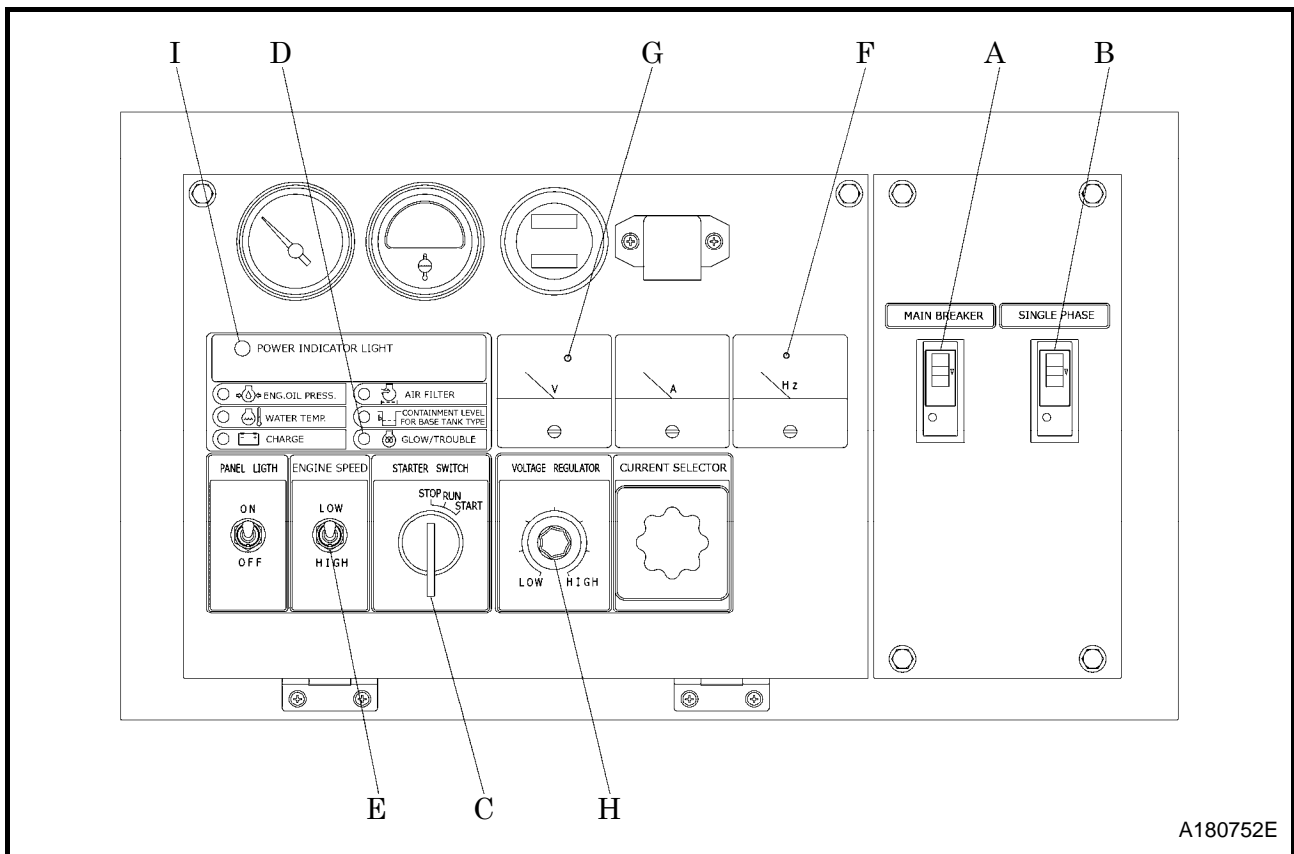

WARNING



- Keep the output terminal cover shut and locked whenever the machine is running. Note that a voltage of several hundred volts is applied to the output terminal and control board. When opening the output terminal cover is unavoidable, be careful not to touch the output terminal. Electric shock or serious injury could result.

3. Operation

<Check frequency and voltage>

1. After finishing warming up operation, check and confirm frequency meter [F].
2. While watching the voltmeter [G], turn the voltage adjuster [H] knob to set the voltage to the rated.
(See 3.6.2)
3. The power indicator light [I] is lighted green during operation.

<Operation with Load>



1. Set the Three-phase circuit breaker [A] and Single-phase circuit breaker [B] to [ON] and supply power to the load.
 2. During operation, check and confirm whether the generator functions properly. (See. Next page)
- ※ Before starting to supply power to the load, make sure that the voltage is in accordance with the load.

IMPORTANT

- After the engine starts up, warm it up unloaded for approx. 5 minutes.
- Warming up after starting up is necessary for smooth operation of the engine.
Do not operate the engine at full load immediately after it starts up.
This will shorten the equipment life.
- During the warm-up operation, examine the different parts of the equipment for any looseness, leakage of water, oil, fuel, and other irregularities.
- Also, make sure that the alarm lamps are off.
- Be sure to operate the generator at the rated frequency, irrespective of the load capacity.
If the machine is operated with a frequency lower than the rated frequency, it could cause the generator main machine or to be burned.

3.6.2 Gauge indication while operating

- During normal operation, each indication of instruments is shown in the table below.
Refer to the table for daily checks.

		Voltmeter (V)	Frequency meter (Hz)	Ammeter (A)	Monitor lamp				
					Engine oil pressure	Water temp.	Charge	Air filter	oil fence
Before Starting up	Starter switch (RUN)	0	0	0	 ON	● OFF	 ON	● OFF	● OFF
		During operation (Full load)	240	60	30 or less	● OFF			
During operation (Unload)		240	60	0					

3. Operation

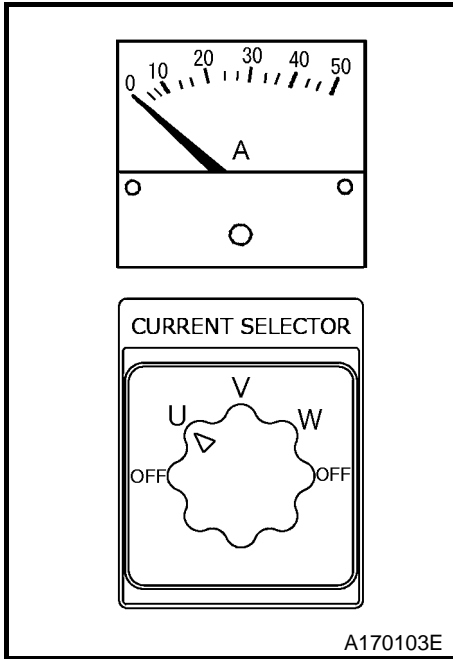

- Be sure to check at times to see if gauges or each component of the machine are properly working, or if there is any air-leak, oil-leak, water-leak or fuel-leak etc.
 - The table above gives standard values. They may vary slightly depending on the operating conditions and other factors.
 - In single-phase load operation, check the current of U, V, and W phase with the ammeter, by turning the current selection switch.
- When each current is unbalanced, change load connections so that the current of U, V, and W, can be equally balanced. Also make sure that the current of each phase does not exceed the rated one.
- ※ Keep the operation log to record constant inspection of each component, so that trouble of the machine can be easily discovered and preventive measures can be taken.

CAUTION

PK0028

- Do not under any circumstance, open the portions below during operation.
- Coolant drain valve
- Engine oil drain valve

CAUTION

H990432

- Never work nearby hot portions of the machine while it is running.
- Do not touch hot portions of the machine while inspecting the machine when running.
- Parts such as the engine, exhaust manifold, exhaust pipe, muffler and radiator are especially hot. Never touch those parts, because it could cause scalding.
- Coolant water and engine oil are also very hot and dangerous to touch. Avoid checking or refilling them while the machine is running.

CAUTION

- When the breaker functions often during operation, reduce the load.
- When using 1-phase load, check the current of each phase and try to keep the load of each phase constantly average.
- If you continue to operate the generator while ignoring or neglecting these cautions, it could cause overheating and result in fire. Furthermore, should operation continue at a lower level than the standard rated frequency, it could burn the generator and any motors of the attached load.

3. Operation

3.6.3 Panel light

- The control panel is equipped with an LED light. Turn the panel light switch [ON] to use.
- When illumination is not necessary, turn the light [OFF]. If the machine is always operated with the lamp switched [ON], the lamp life can be reduced.

3.6.4 Procedure of stopping

<Procedure>

1. Power off of all connected loads.
2. Set the Three-phase circuit breaker [A] and Single-phase circuit breaker [B] on the control panel of the machine to [OFF] position.
3. After about 5 minutes cooling down operation, turn the starter switch [C] to [STOP] position.

3.6.5 Operating procedures when engine fails to start up on first attempt

When the engine fails to start up even following the start-up procedures, do not keep the starter running, but set the starter switch back to [STOP] and wait about 30 seconds. Then, repeat the start-up procedure once again. If the repeated procedure does not allow the engine to run, the following causes are suspected. Therefore, check the following:

- No fuel
- Clogging of the fuel filter
- Discharge of battery (Low cranking speed)

3.6.6 Fuel line air bleeding device

If the machine runs out of fuel, bleed the air, according to the following procedures.

<Procedure>

1. Replenish fuel.
2. Turn the starter switch to [RUN] position.
Then the electric pump will start to automatically bleed air from the fuel pipes.
3. Air bleeding will be completed within 20-30 seconds.

3. Operation

3.7 Emergency Stop

3.7.1 Emergency stopping procedures

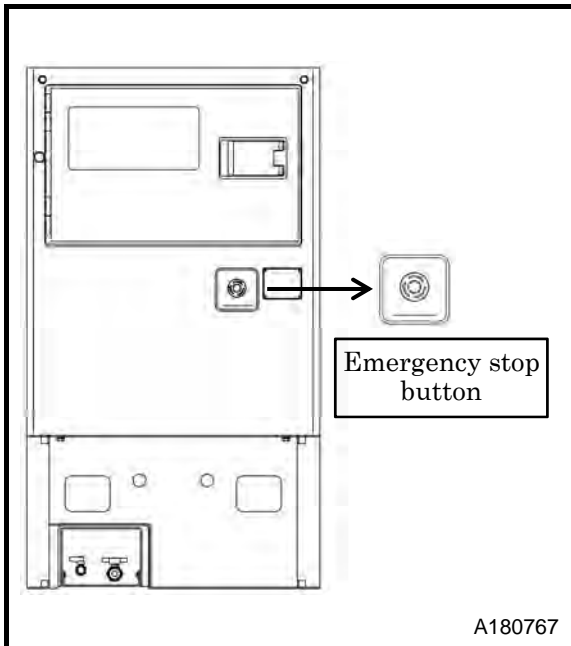

- If it is necessary to stop the generator for emergency, press the Emergency Stop button located under the control panel.
When shutting down with the emergency stop button, the machine will stop immediately.

3.7.2 Cancellation of emergency stop button

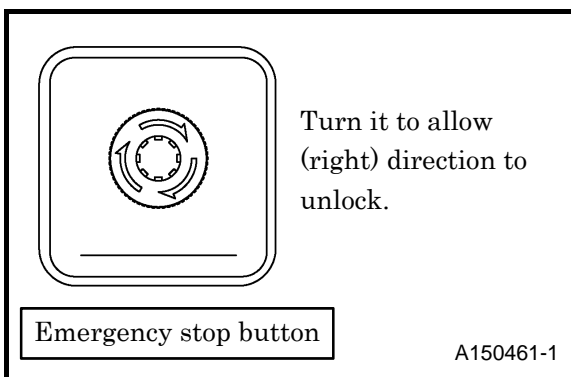

- After emergency stopping, be sure to carry out an investigation of the problem which caused you to use the emergency stop and take appropriate countermeasures. Release emergency stop button only after resolving the problem that required an emergency stop. To reset the button, turn the button head in the direction of the arrow.
※ If it is not reset, the machine cannot restart.

4. Failure and Troubleshooting







4.1 Protection device

To prevent issues during operation, this machine is equipped with various protection devices.

4.1.1 List of protection devices

This machine is equipped with the following devices in the table.

Repair and make necessary treatment in accordance with the item ○.

Item	Engine stops	Circuit breaker trips.	Warning display ※1	Abnormality display ※2	Monitor lamp	Functions
Engine oil pressure drop	○	—	○	○		When engine oil pressure drops, it functions. Operating pressure: lower than 7.25PSI(0.05MPa)
Water temperature rises ①	○	—	○	○		In case of abnormal rise of engine water temperature, it functions. Operating temperature: 239°F(115°C)
Water temperature rises ②	○	—	○	○		If water temperature switch should not function and water temperature should rise higher, this switch could function. Operating temperature: 248°F(120°C)
Over current or short circuit	—	○	—	—	—	In case of overload or short circuit accident, it functions.
Discharged battery	○	—	○	○		It functions when improper battery charging happens due to the break of belt, etc.
Clogging of air filter	—	—	○	—		When air filter is clogged and it becomes necessary to clean it, it functions.
Elevation of the level of oil fence ※3	—	—	○	—		When condensate (fuel, engine oil and coolant) is accumulated more than 5.3gal (20 liters)

※1 **When the contact point of abnormal inspection switch turns “ON”, it makes the lamp of warning display lights up.**

※2 **When the fault diagnosis functions actuates, it blinks the abnormality display lamp. The fault condition is represented by the flashing patterns of the lamp.**

※3 **When the monitor lamp lights in the oil fence, immediately drain it. (For the capacity of the oil fence, refer to 7.1 Specifications). To protect environment, do not drain it directly into rivers. (For details, See PS-6)**

CAUTION

- If the protective device operates and the engine stops or the circuit breaker trips, refer to the cause of the failure and the countermeasure item, eliminate the cause and restart operation.

4. Failure and Troubleshooting

4.1.2 Emergency stop function

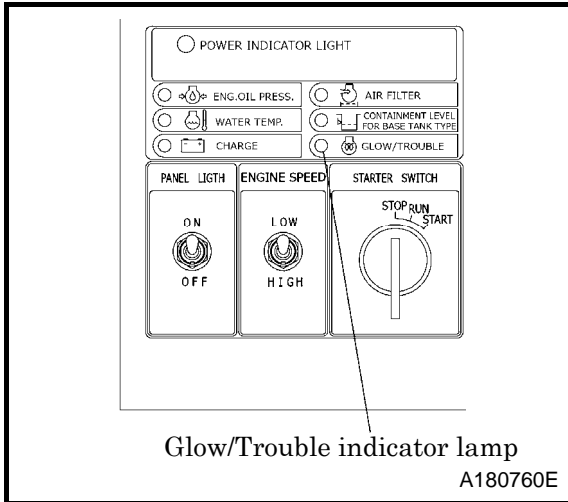

- This unit is equipped with the following protection devices. According to the kinds of trouble, the glow/trouble indicator lamp indicates each trouble by the pattern of flickering and also functions to stop engine in emergency.

Trouble	Flickering pattern of trouble indicator	Functions
Excessive RPM	L 1 and S 1	When engine speed rises abnormally, it functions. RPM speed: 2,070min ⁻¹
Drop of engine oil pressure	L 1 and S 2	When engine oil pressure drops, it functions. Function oil pressure: less than 7.25PSI(0.05MPa)
Battery charging faulty	L 1 and S 3	When battery charging is not performed well owing to a broken belt, it functions.
Rise of coolant temperature ①	L 1 and S 4	When engine coolant temperature rises abnormally, it functions. Function temperature: 239°F(115°C) (Water temperature switch)
Rise of coolant temperature ②	L 1 and S 6	When engine coolant temperature rises abnormally, it functions. Function temperature: 248°F(120°C) (ECU)
Protection of starter	L 1 and S 7	When starter continues to run longer than 12 seconds.
Malfunction of RPM sensor	L 2 and S 1	When RPM sensor is in disorder or cable connection is disconnected or short-circuited.
Trouble of solenoid sensor	L 2 and S 2	When cable of actuator is disconnected or short-circuited.
Disconnection of coolant temperature sensor	L 2 and S 4	When cable of coolant temperature sensor is disconnected.
Short-circuiting of coolant temp. sensor	L 2 and S 5	When cable of coolant temperature sensor is short-circuited.
Disconnection of alternator L terminal	L 2 and S 6	When cable of alternator L terminal is disconnected.
Abnormal sensor power supply	L 2 and S 7	When ECV power supply short circuits. (Analog 5V goes lower than 4V)
Excessive voltage	L 3 and S 1	When voltage of alternator rides abnormally. Function voltage: 18V.
Running out of fuel	L 3 and S 2	When engine stops due to running out of fuel or fuel system clogging.
Engine pulse abnormality	L 3 and S 4	When a crank gear tooth abnormality is detected.

※When engine is brought to emergency stop, some of the above flashing patterns is indicated.
L and S mean Long time and short time alternatively. Also the numbers of each L and S mean repeated time of flickering lamp.

4. Failure and Troubleshooting

4.1.3 Circuit Breaker

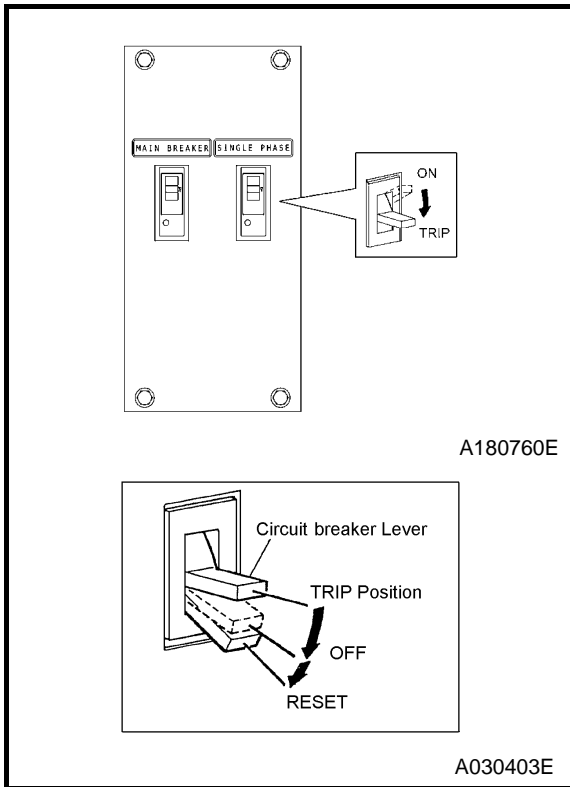

- In case of an overload or short-circuited wire connection, the circuit-breaker trips.
- When the breaker is tripped, stop the machine immediately and reset the circuit breaker after resolving the cause of the trouble.

<How to reset>

- In order to reset the lever of circuit breaker, press the lever downward firmly until the lever “clicks” into place.

4.1.4 Circuit protector (CP) for AVR protection

AVR is equipped with a circuit-protector (CP) for protection against over current. It will activate under the following conditions:

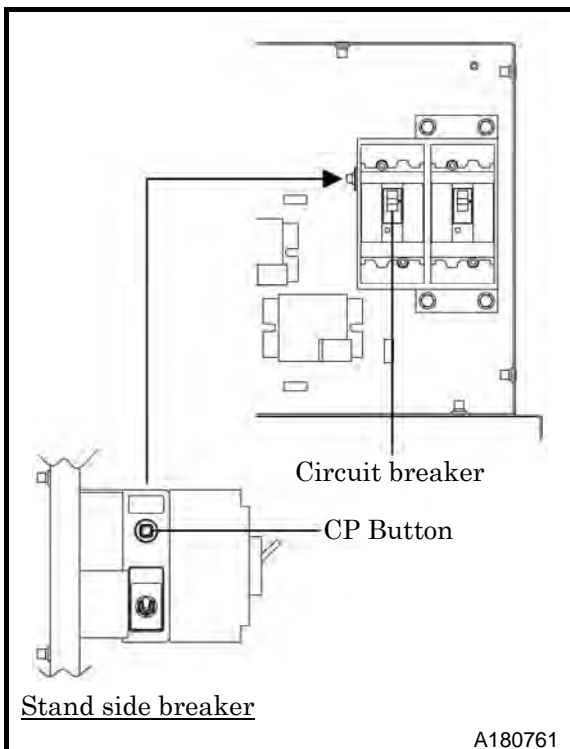

- The machine is overloaded while engine speed is still low.
- The output voltage of machine is increased higher than the specified voltage.

<Symptom>

- When the CP operates, following symptoms will occur.
 1. The voltage will not reach rated voltage.
 2. The voltage is usable, but voltage fluctuation is wide and voltage restoration is slow when loaded.

<How to reset>

- Reset it by pressing CP (AVR) button provided at the side of the breaker plate in the control panel.

4. Failure and Troubleshooting

4.2 Troubleshooting

Should any trouble occur during operation, do not leave it. Investigate the cause and take appropriate measures. Read the manual carefully and fully understand what to do in case of trouble.

- The better you understand the construction and function of the machine, the faster you can find a problem and solution.
- This chapter describes the state, cause and countermeasures of important troubles in detail:

4.2.1 Generator version

Symptom	Cause	Counter measures								
Starter does not rotate. Low starter revolution speed even when starting.	(1) Battery malfunction (2) Charging malfunction (3) Alternator malfunction (4) Starter malfunction	<table border="0"> <tr> <td style="font-size: 2em; vertical-align: middle;">}</td> <td>Check battery → Charge</td> </tr> <tr> <td></td> <td style="text-align: right;">Change</td> </tr> <tr> <td></td> <td>Change</td> </tr> <tr> <td></td> <td>Change</td> </tr> </table>	}	Check battery → Charge		Change		Change		Change
}	Check battery → Charge									
	Change									
	Change									
	Change									
Starter rotates normally but engine does not start up.	(1) No diesel fuel oil (2) Air mixing in fuel piping (3) Fuel filter clogging (4) Nozzle clogging (5) Malfunction of controller	Replenish fuel Bleed air Disassemble/Clean and Change Disassemble and clean Check fuse Check connector Check controller								
Engine oil pressure drop monitor lamp glows.	(1) Engine oil shortage (2) Engine oil filter clogging (3) Loosened or disconnected wiring, or connector (4) Oil pressure switch malfunction	Replenish fuel Change Check/fasten Change								
Coolant temperature rise monitor lamp glows.	(1) Shortage of coolant (2) Slip of belt (3) Radiator clogging (4) Faulty thermostat (5) Looseness, disconnection of wiring or connectors (6) Faulty coolant temperature switch	Replenish Adjust tension Clean Change Check/fasten Change								
Recharging monitor lamp glows.	(1) Looseness, disconnection of wiring or connector (2) Alternator problem	Check/fasten Change								
Air filter clogging monitor lamp glows.	(1) Air filter clogging	Clean								

4. Failure and Troubleshooting

Symptom	Cause	Counter measures
Oil fence monitor lamp glows.	(1) The condensate (fuel, engine oil and coolant) is accumulated in the oil fence. (2) The liquid surface level detecting switch does not function good.	Drain the condensate Check/change
Circuit breaker trips.	(1) Overloaded (2) Short-circuit occurred at the load side.	Reduce the load Get rid of cause of short-circuiting.
Even when operated at a rated speed, no voltage or too low voltage generated.	(1) Poor tightening of terminals (2) Frequency selector switch does not match frequency produced (3) Broken or short-circuited circuit to exciter field winding (4) Faulty exciter (5) Function circuit protector (CP) for AVR protection (6) Faulty AVR (7) Broken or short-circuited winding of generator main unit (8) Faulty silicon rectifier (Installed on generator rotor) (9) Faulty voltmeter	Check/fasten Check/change Repair Repair Reset Change Repair Change Change
Too high voltage generated when set at the rated frequency , Voltage will not drop even when the voltage regulator controlling knob is turned.	(1) Loosened or disconnected wiring, or connector to AVR (2) Broken wire or poor contact of AVR variable resistor (3) Faulty AVR	Check/fasten Repair or change Change
Unstable voltage generation	(1) Poor tightening of each terminal (2) Function circuit protector (CP) for AVR protection (3) Faulty AVR	Check/fasten Reset Change

- Contact your nearest dealer if you find it difficult to repair by yourselves.
- Prefer the section “4.2.2 Engine Body” when facing engine trouble.

4. Failure and Troubleshooting

4.2.2 Engine body

In case engine trouble occurs, refer below table and do appropriate check and maintainance.

Phenomenon	Cause	Treatment method
In case hard to start engine	(1)Fuel would not flow	(1)Check fuel tank and remove impurities and water
		(2)Check fuel filter and replace it if it is dirty
	(2)Air and water are mixed in fuel oil piping	(1)Check pipe and tightening band and replace it with new one or repair it if it is damaged
		(2)Remove air
		(3)Remove water or change fuel
	(4)Check if the nozzle works properly or not. If not, replace it with new one	
(3)Oil viscosity is high at cold time. Engine rotation speed is low.	(1)Use oil properly according to temperature	
(4)Battery tends to go flat. Engine rotation speed is low. Engine would not work to start compression.	(1)Charge battery	
In case output shortage	(1)Fuel shortage	(1)Replenish fuel
		(2)Check fuel system (Especially beware of air mixing)
	(2)Air filter clogging	(1)Clean element
	In case engine stops suddenly	(1)Run out of fuel
(2)Check fuel system (Especially beware of air mixing)		
(2)Shortage of lubricating oil or poor lubrication		(1)Check engine oil quantity by looking at oil level gauge
		(2)Check lubricating oil system
In case exhaust gas color is bad	(1)Bad fuel is used	(1)Replace fuel with good one
	(2)Excessive quantity of engine oil is used	(2)Change oil quantity as regulated one
	(3)Incomplete combustion	(3)Check fuel system
In case overheat	(1)Cooling water boiling	(1)Check shortage and leakage of cooling water
		(2)Check tightness and looseness of fan belt
		(3)Clean dust in radiator fin tube
	(2)Shortage of engine oil	(1)Check oil level. Replenish oil if necessary
	(3)High concentration of LLC (antifreezing fluid)	(1)Replenish water only. Or replace it with LLC of designated mixing ratio
(4)Overload operation	(1)Reduce the load	

5. Periodic Inspection

5.1 Important Items at Periodic Inspection and Maintenance

The following table shows the inspection and maintenance intervals under normal operation conditions. When used or operated under hard environmental conditions, it is impossible to warrant the machine even if the above conditions are performed according to the intervals listed in the above table.

- Be sure to use appropriate tools for inspection and maintenance work. Inappropriate tools could cause unexpected injury.
- Please wear personal protective equipment such as a helmet, safety glasses, earplugs, safety shoes, gloves, and a mask as appropriate to the work environment
- Do not touch hot portions of the machine while inspecting the machine when running. Parts such as the engine, exhaust manifold, exhaust pipe, exhaust muffler, radiator, inter cooler, generator, and pipe are especially hot, so never touch those parts, because it could cause scalding.

WARNING

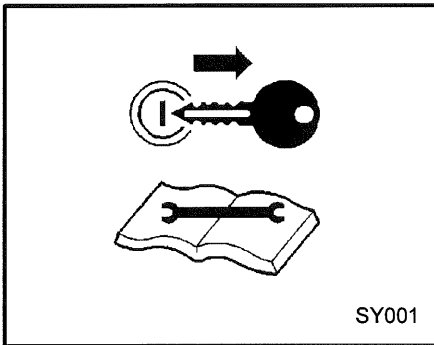

Hang a “Under Maintenance” tag

- Before starting inspection, switch off the circuit breaker of this machine, remove the starter key from the starter switch, and then hang a “Now Checking and under Maintenance” tag where it can be easily seen.
The checker must keep the key during checking and maintenance.
- Remove the negative (–) side cable from the battery. If the above procedure is neglected, and another person starts operating the machine during check or maintenance, it could cause serious injury.

IMPORTANT

Instructions and unspecified work prohibited

- Be sure to use recommended fuel, DEF, oil, grease, or antifreeze.
- Do not disassemble or adjust engine, generator or part(s) for which inspection or maintenance is not referred to in this manual.
- Use genuine parts for replacement.
- Any breakdown, caused by using unapproved parts or by wrong handling, will be out of the scope of “WARRANTY”.
- Do not pour water or steam on electrical components.
- Place a container or a pan underneath the oil port to receive waste liquid so that such liquid cannot be spilt out on the floor or inside the machine.
- Be sure that no waste liquid is disposed of on the ground. Such waste on the ground, river or lake will cause serious environmental contamination. Be sure to follow the local regulations. If harmful materials such as oil, antifreeze solution or filters are disposed of incorrectly, the responsible person should be punished by the authority.
- Observe local regulations when disposing of such toxic materials as oil, fuel, coolant (Antifreeze), filters, and battery etc.

5. Periodic Inspection

5.2 Maintenance Schedule

Such items marked ○ shall be carried out by customers. For the following items or clauses marked ●, contact your nearest dealer because they require expert technical knowledge on them.

The following table shows the intervals of inspection and maintenance under normal operation conditions. Inspection and maintenance should be done at either of the hour or the period mentioned in the remarks column, whichever comes earlier.

(This table is a guide only, it is not a guaranteed time. Please change maintenance interval according to usage load environmental condition.)

Maintenance	Daily	Every 50 hours	Every 250 hours	Every 500 hours	Every 1,000 hours	Ref.	Remarks
Generator	Clean instruments in control panel	○				3-11	Clean as required.
	Check thermo-label of alternator	○				3-13	
	Check each instrument and warning lamp.	○				3-15	
	Check GFCI receptacles			○		5-8	Every 1 month
	Check insulation resistance			○		5-9	Every 2 months
	Check thermos-label on the generator			○		5-10	Every 2 months
Engine related	Check engine oil level	○				3-8	
	Check coolant level	○				3-9	
	Check fuel	○				3-10	
	Check fuel filter drain	○				3-10	
	Check belt tension	○				3-12	In the case of NG, it exchanges.
	Change engine oil		○ (First time)	○		5-4	
	Change engine oil filter		○ (First time)	○		5-5	
	Check battery electrolyte			○		5-5	
	Check and clean air filter elements			○		5-7	Perform cleaning when the monitor lamp glows.
	Check accumulations in exhaust system			○		5-8	
	Drain fuel tank			○		5-10	
	Check specific gravity of battery electrolyte.				○	5-5	
	Change fuel filter element				○	5-10	
	Clean outside of radiator				○	5-11	Clean as required.
	Check exhaust flexible pipe				○	5-13	Every 4 months
	Change air filter element					○ 5-12	
	Change coolant (LLC)					○ (Every 2 years) 5-14	
	Check engine fuel hose.		○ (Check)			5-13	Every 2 years
	Clean inside the fuel tank.					●	
	Others	Check oil fence drain	○				3-11
Check terminal and wirings					○	5-11	Every 4 months
Check engine/generator mount					○	5-13	Every 1 year
Check each rubber hose					○	5-13	Every 1 year
Clean the oil fence and check for rust						● 5-13	Every 1 year

The above intervals of inspection and maintenance are respectively based on the operation time of 125 hours of used per month and of 1,500 hours of use per year.

5. Periodic Inspection

Maintenance		Every 1,000hours	Every 1,500hours	Every 3,000hours	Remarks
Engine body	Check engine valve clearance.	●			Please contact nearby distributor or engine distributor for inspection and maintenance.
	Adjust fuel injection nozzle		●		
	Check fuel injection timing			●	

5.3 Periodic Replacement Parts

Part number changes upon modification. For replacement of parts, make sure whether the part number is correct or applicable.

Description	Part Number	Q'ty
Engine Oil Filter Element	37438 07800	1
Air Filter Element	32143 11400	1
Fuel Filter Element [D]	43541 01300	1
O-ring for fuel filter [E]	KUBOTA 04811-50650	1
O-ring for fuel filter [F]	KUBOTA 04816-00160	1
Belt	KUBOTA 1G382-9701-0	1
Engine fuel hose	KUBOTA 17331-4250-2	1

5. Periodic Inspection

5.4 Maintenance Items

5.4.1 Change Engine Oil (Change the engine oil filter at the same time)

At 50 hours for the first change and every 250 hours thereafter

When checking, replenishing, and draining the engine oil, be sure to wait more than 10 minutes after engine stops to allow it to cool down.

<Procedure>

1. Remove the drain plug [A] attached outside the plane, open a drain valve [B] inside the plane, and discharge engine oil drain.
2. When the oil is completely drained, close a drain valve [B] after attaching a drain plug [A], remove the cap of an engine oil filler port [C], refill new engine oil.

[Oil supply: about 6.5L]

3. After finishing the oil supply, tighten the cap of engine oil filler port firmly.
4. Make sure to check engine oil level with the engine oil level gauge before start the unit.
5. After finishing the oil supply, tighten the cap of oil filter port firmly.

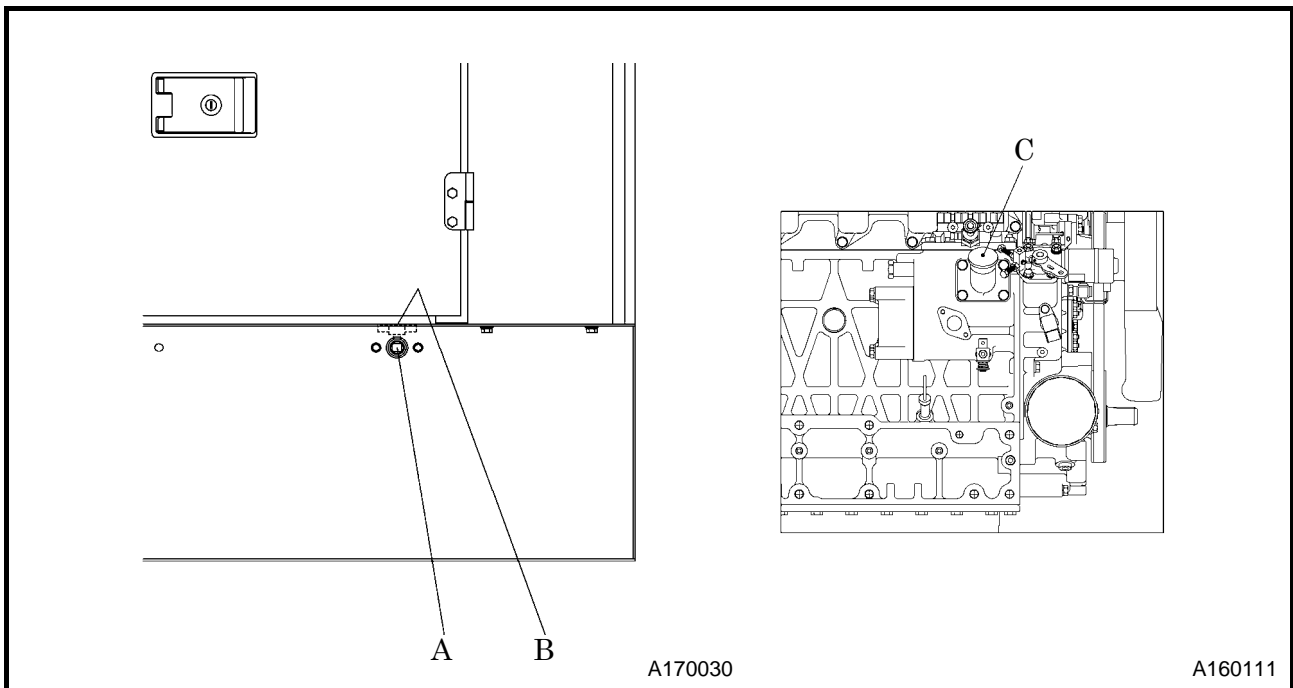

CAUTION

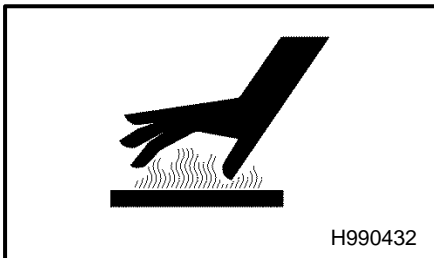

Caution in filling or draining engine oil

- Engine oil is very hot and highly pressurized during or just after the operation. Hot oil could blow out and can cause injury
- Never supply more engine oil than the proper level. Too much oil could cause white smoke out of the exhaust, and it can cause damage and accident to engine.

5. Periodic Inspection

5.4.2 Change Engine Oil Filter Element

At 50 hours for the first change and every 250 hours thereafter

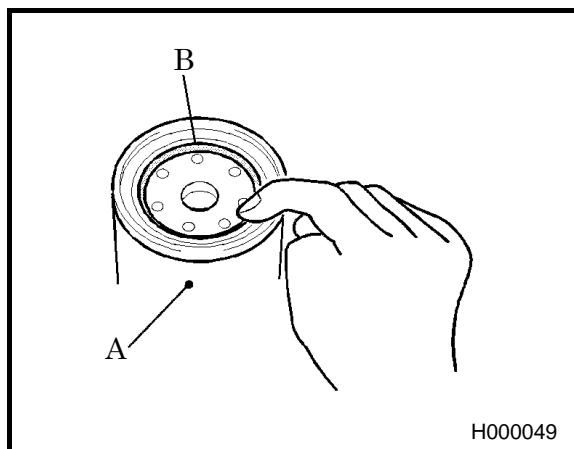

<Procedure>

1. Take out the oil filter element [A] using a filter wrench.
2. After coating fuel on the new oil filter element packing [B], screw it in. After the packing touches the sealing face, tighten another 2/3 turn with a filter wrench.
3. After installing the oil filter element, check it for any leak during operation. **(For part number, See 5.3)**

5.4.3 Check Battery

Battery electrolyte : every 250 hours

Specific gravity of battery electrolyte : every 500 hours

If there to be a problem in starting an engine due to a flat battery, carry out the checks by following the procedures below:

- **Ordinary type battery:**

Measure specific gravity of battery electrolyte, and if it shows below 1.24, recharge the battery immediately. **(See 5.4.4)**

- **Enclosed type battery:**

Check the indicator on top surface of the battery.

If the indicator shows that charge is needed, recharge the battery immediately.



If specific gravity of battery electrolyte does not rise despite replenishing distilled water or charging battery, replace battery with a new one quickly.

5. Periodic Inspection

5.4.4 Maintenance of Battery

Battery may generate hydrogen gas and may explode. Therefore, recharging should be done at a well-ventilated place.

- Do not check the battery by short-circuiting the positive and negative terminals with a metallic piece.
- Never operate the machine nor charge the batteries with low battery liquid. Continuing operation at this lower level will cause deterioration of some parts, reduction of battery life, and also it may cause explosions. Add distilled water so that the liquid level is between the “UPPER LEVEL” and “LOWER LEVEL” if the level is too low.
- Wear protective gloves and safety glasses when handling a battery.
 - If battery electrolytes contact your clothes or skin, wash it away with a large amount of water immediately.
 - If the battery electrolytes get into your eyes, flush them immediately with plenty of water and see a doctor at once. Severe damage to eyes and vision may result.

WARNING	Handling Battery
 D004	<ul style="list-style-type: none">● Keep flames away from battery.● Do not spark near the battery nor light a match, nor bring lit cigarette and match close to the battery.● Do not charge a frozen battery as it may explode. If the battery is frozen, warm it up until the battery temperature becomes 61°F to 86°F (16°C to 30°C).● Battery electrolyte is diluted sulfuric acid. In case of mishandling, it could cause skin burning.● Dispose of battery, observing local regulations.
 W010	
 TR0093	

[Charge battery]

- Use the battery charger after you confirm whether it is in good operating condition and ready for use.
- Disconnect the cable between battery and the machine, and charge the battery with a 12V battery charger. Do not charge two batteries at the same time.
- Be sure not to connect (+) and (-) terminals backwards.

5. Periodic Inspection

[How to use booster cable]

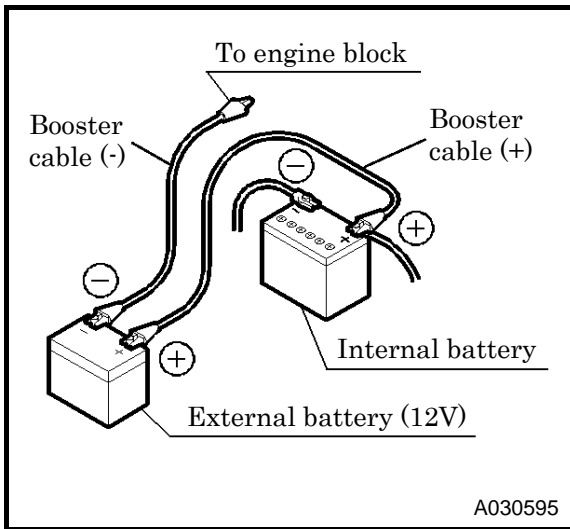

<Procedure>

1. Stop the engine.
2. Connect one end of the (+) booster cable to the (+) terminal of the machine battery.
3. Connect the other end of the (+) booster cable to the (+) terminal of the external battery.
4. Connect one end of the (-) booster cable to the (-) terminal of the external battery.
5. Connect the other end of the (-) booster cable to the engine block of the machine.
6. Start up the engine.
7. Disconnect the booster cable by following the procedure back in the reverse order.

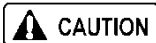

CAUTION *Do not reverse the cable connection*

- When a booster cable has to be used or when cables are connected again after a battery is replaced, be careful not to connect (+) and (-) terminals backwards. A backwards connection will cause sparking and damage to each component.

5.4.5 Check and Clean Air Filter Elements

Every 250 Hours

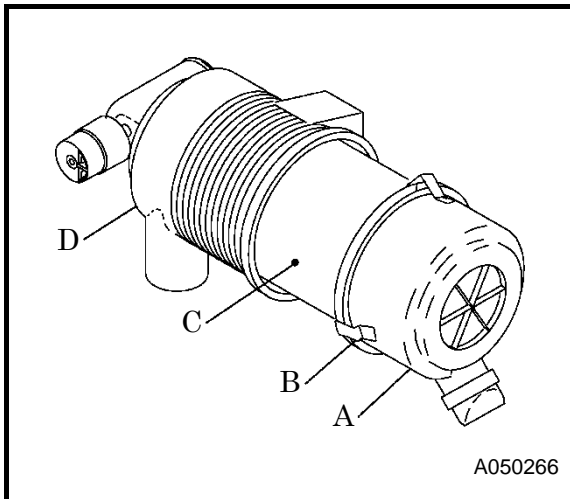

When the air filter monitor lamp glows, clean the air filter.

<Procedure>

1. After removing the cap [A] by loosening its cap fixing latch [B], clean its interior properly.
 2. Remove the element [C], and clean it.
 3. When installing the cap after finishing the cleaning job, push the element into the case [D] firmly by hand, and then make sure that the cap fixing latches attach securely to the case. Lastly, tighten the latches.
- If the element is found heavily dusty, replace it with a new one. **(For part number, See 5.3)**

IMPORTANT

- When an element that is clogged or has holes or cracks is used, dust or foreign material will get in the engine. This causes accelerated wear in moving parts within the engine. Be sure to perform daily checks and appropriate cleaning so that the life of the engine will not be shortened.

5. Periodic Inspection

5.4.6 Check Accumulations in Exhaust System

Every 250 Hours

When a diesel engine driven generator is continuously operated with less than 30% load or no load for a long time, carbon will be stuck inside the exhaust pipes, exhaust muffler, and engine body. Unburned fuel may also come out from connected portions of exhaust pipe and outlet port of the exhaust muffler. If it is continuously operated under the conditions, the fuel which comes out could ignite and cause a fire.

Further, wet-stacking and carbon accumulation could cause power drop in the engine as well as overheating, resulting a serious damage to the engine. If this occurs, eliminate the carbon accumulation by burning it under full load operation (to increase exhaust heat) until the exhaust gas becomes almost clear.

(For load current, refer to the following table as a standard value.)

Frequency	Hz	60
Rated voltage	V	240
Load current	A	24

CAUTION

- In case of load operation, increase load factor step by step with checking the conditions of exhaust. Do not place flammables surroundings because it could sometimes cause sparks from exhaust pipe.

5.4.7 Check GFCI Receptacles

Every 1 month or 250 Hours

Periodically, check the GFCI operation for safety.

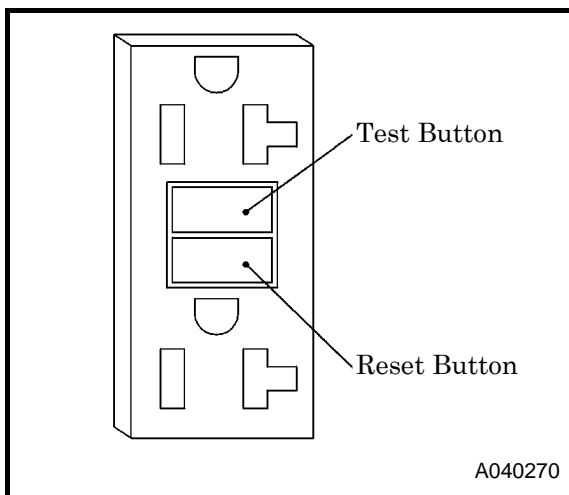

<Procedure>

1. Unplug all appliances from the generator.
2. Start the engine.
3. Turn [ON] the breaker on the instrument panel of this machine.
4. Press the test button.
5. Press the reset button.
 - The reset button should extend with a click.
 - If the reset button does not extend, contact your nearest dealer.
6. When the reset button extends during operation.
 - Unplug all appliances from the GFCI protected receptacle.
 - Press the reset button:

If the GFCI cannot be reset: The GFCI is faulty. Contact your nearest dealer.

If the GFCI resets properly: Check the appliance or the power cord.

DANGER

- If the generator is stored outdoors, unprotected from the weather, test the GFCI receptacle before each use.
- In case the GFCI has tripped due to the hazard of ground fault currents, investigate the cause and correct it.

5. Periodic Inspection

5.4.8 Check Insulation Resistance

Every 2 months or 250 Hours

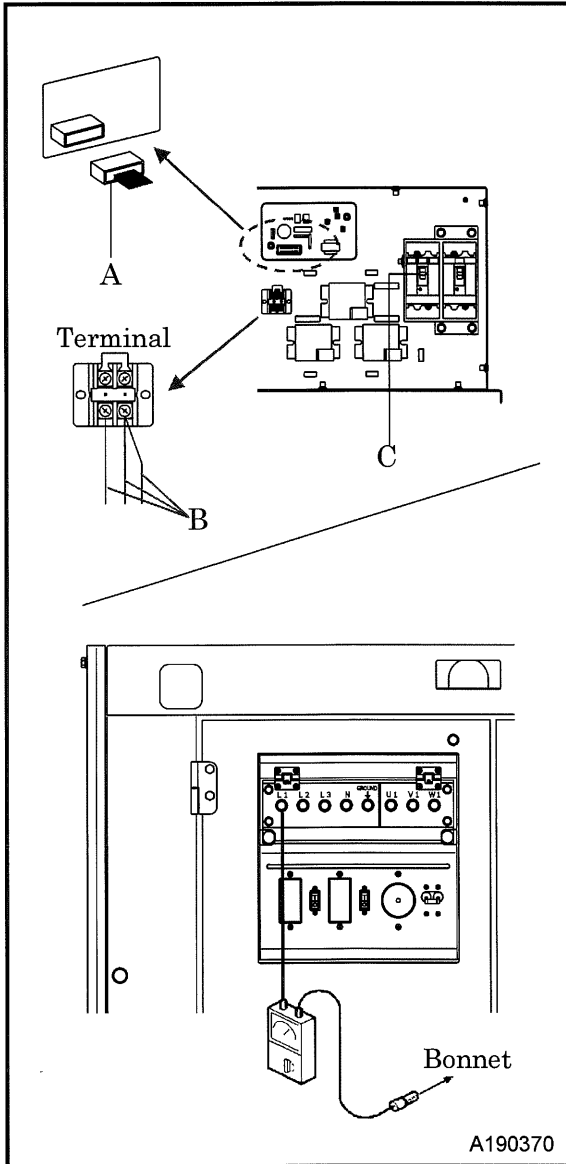

<Procedure>

1. Remove the load side cable from the output terminal board.
2. Remove the connector [A] inside the generator control panel.
3. Remove the 3 lead wires [B] from the lower side of the terminal block in the control panel.
4. Switch ON circuit breaker [C], measure each insulation resistance between the terminals L1, L2, L3 terminal and bonnet.
5. If insulation resistance value measured is found more than $1M\Omega$, it is good.
6. After insulation resistance has been confirmed, return the AVR [A] and the terminal block leads [B] to their original states.

IMPORTANT

- Insulation resistance should be regularly checked or measured with a 500V insulation resistance meter. If it is reduced to lower than $1M\Omega$, it could cause an electrical leakage or a fire.
- For recovery or improvement of insulation resistance, wipe and clean dust and dirt around output terminals, circuit breaker, generator body outlet port and receptacle and dry them. If it insulation resistance does not recover after cleaning, contact your nearest dealer.

5. Periodic Inspection

5.4.9 Check Thermo-Label on the Generator

Every 2 months or 250 Hours

Thermo-label on the rotor bearing irreversibly changes its color from white to blue by reaching or exceeding 176°F (80°C). Be sure to check the bearing for abnormal noise and vibration if it has changed color.

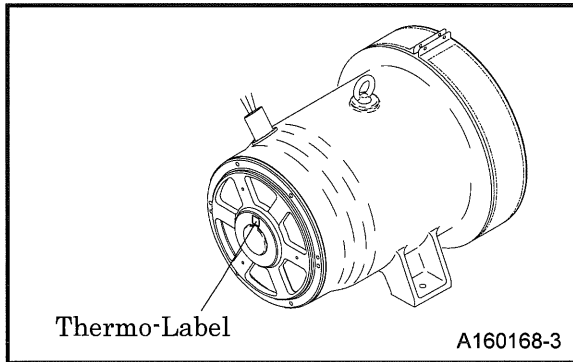

- Replace thermo-label if it has changed color.
- When replacing, contact your nearest dealer.

5.4.10 Drain Fuel Tank

Every 250 Hours

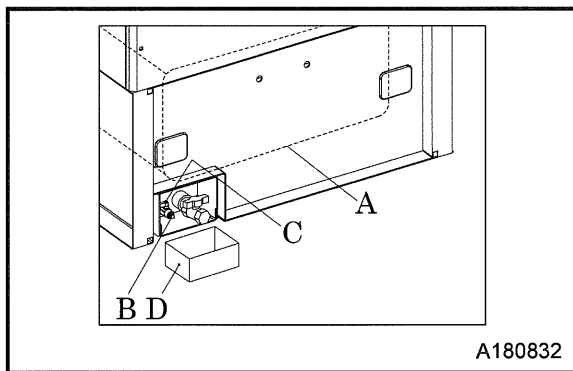

- To drain fuel tank, remove drain plug [B], and open drain valve [C] to drain the condensate accumulated in fuel tank [A].
- After making sure that all condensate is completely drained out, close drain valve firmly and install drain plug [B].
- Drain the condensate into a container [D] and dispose of condensate according to applicable regulations.

5.4.11 Change Fuel Filter Element

Every 500 Hours

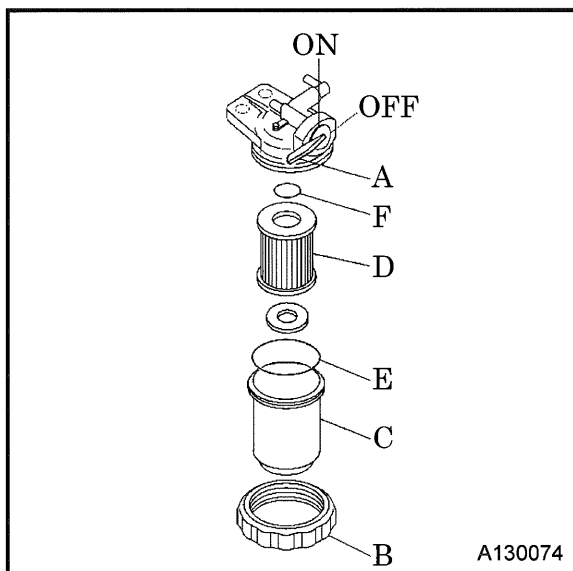

<Procedure>

1. Turn the lever [A] of fuel filter to [OFF] and cut off fuel supply.
2. Remove the cup [C] after loosening the ring nut [B], and then take off the element [D] from the inside.
3. Clean the cup and then install the new element and O-ring [E], [F]. **(For part number, See 5.3)**
4. Install to the body the cup equipped with the element. Then tighten the ring nut securely.
5. Turning lever of fuel filter to [ON] position, supply fuel in the cup. Then bleed air completely from fuel system. **(See 3.6.6)**

5. Periodic Inspection

5.4.12 Clean outside of Radiator

Every 500 Hours

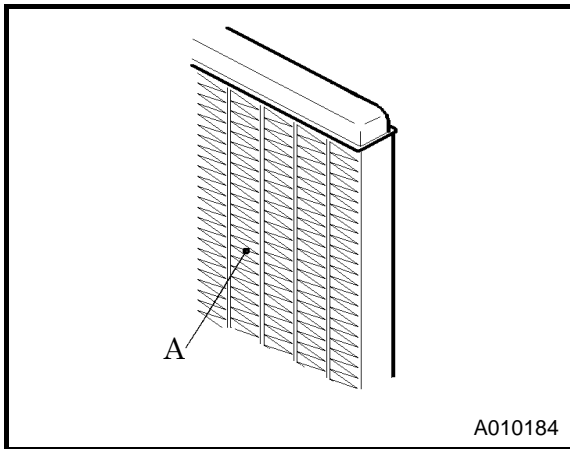

- When the fin tubes [A] of radiator are clogged by dust or other foreign materials, the heat exchange efficiency drops and this will raise coolant temperature. These tubes and fins should be cleaned depending on the state of dirt inside the tubes even before maintenance schedule.
- Do not use high pressure washer for cleaning as it may damage fin tubes.
- When the unit is used or installed near seaside, clean the radiator using fresh water at least than once a month.

5.4.13 Check Terminal and Wirings

Every 4 months or 500 Hours

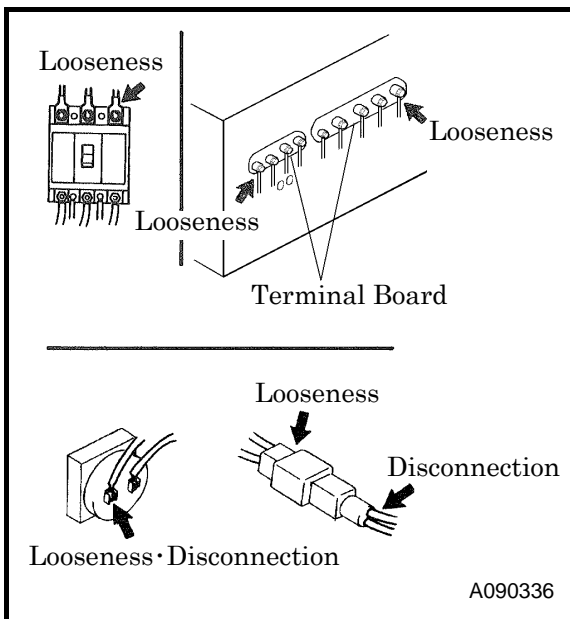

Check for any looseness on the cables, any damage on insulated covers, and disconnection, disconnected cables, or short-circuits etc.

[Checking points of electrical circuits on the generator side]

- Terminal connection of 3-phase output terminal plate.
- Main circuit of circuit breaker.
- Terminal connection on control box.
- Each terminal connection of each instrument.

[Checking points of electrical circuits on the engine side]

- Portion of connectors to the engine.
- Check for looseness of terminal connections.
- Rubbing and wear of the wire.

5. Periodic Inspection

5.4.14 Check Exhaust Flexible Pipe

Every 4 months or 500 Hours

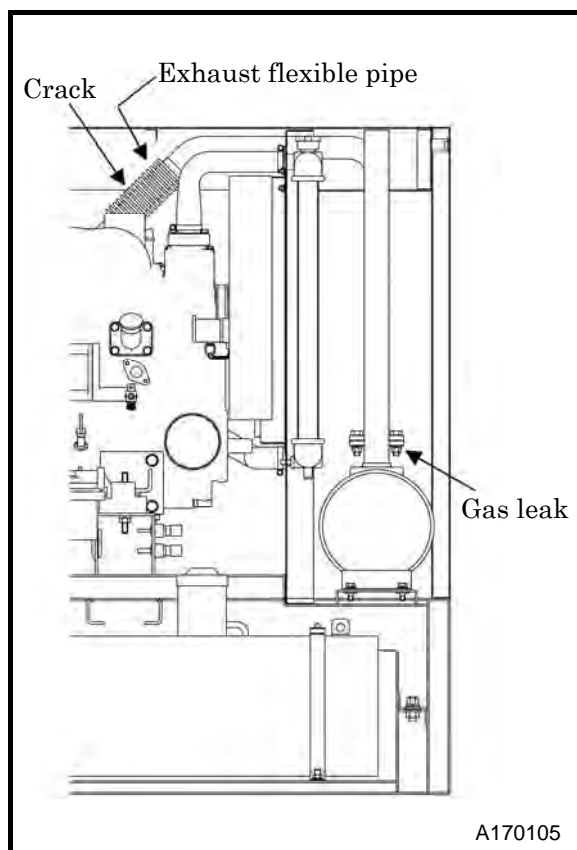

- Check the flexible pipe between the exhaust muffler and engine exhaust outlet for cracks and exhaust gas leakage
- If any leak is found, avoid getting burned by the exhaust gas.

5.4.15 Change Air Filter Elements

Every 1,000 Hours

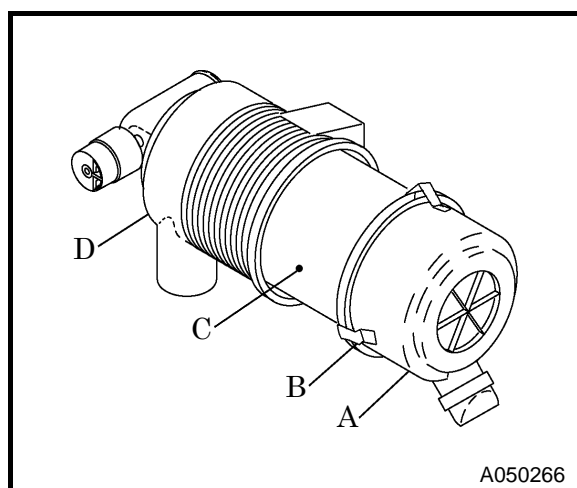

<Procedure>

1. Loosen the cap fixing latches [B] and remove the cap [A]. Clean its inside properly.
2. Replace element [C] with new ones.
(For part number, See 5.3)
3. When installing the cap, firmly push the element into the case [D] by hand and make sure that the hooks of the cap fixing latches are securely attached and tightened.

IMPORTANT

- Air filter is an important part which is crucial to machine's performance and life.
Be sure to use genuine parts.

5. Periodic Inspection

5.4.16 Check Engine/Generator Mount

Every year or 1,000 Hours

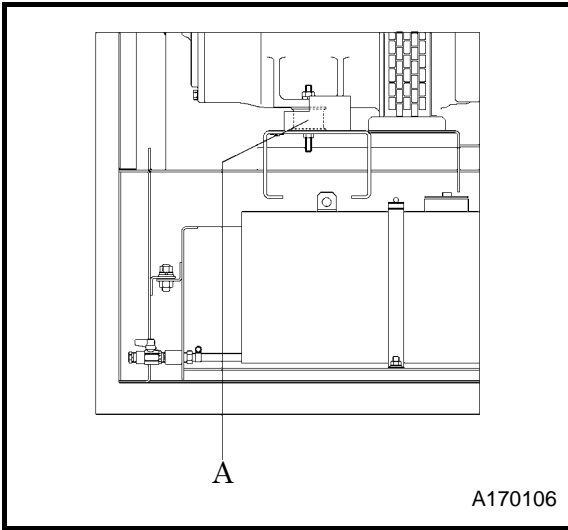

- The vibration isolation rubbers [A] are used for the support of generator and engine. Check the rubber for any damage or deterioration due to oil sticking.

5.4.17 Check Each Rubber Hose

Every year or 1,000 Hours

Check all the rubber hoses for hardening, cracks, and fissures.

- If any hardening, cracks, or fissures are found on a hose (air filter, radiator, fuel and drain), replace it with a new one.
- Check each hose clamp and if any loose hoses are found, retighten them.
- Even before the maintenance interval comes, replace hoses if hardening, cracks, or fissures are found. When replacing, contact your nearest dealer.

5.4.18 Check and change engine fuel hose

Check every 50 hours / Change every 2 years

- Rubber hoses become hardened or deteriorated, replace them even before the specified hours or periodical intervals.
- Ask your nearest dealer for its replacement.

5.4.19 Clean the oil fence and check for rust

Every year or 1,000 Hours

Expert knowledge is required to clean the inside of the oil fence and to check it for rust. Contact your nearest dealer.

5. Periodic Inspection

5.4.20 Change Coolant

Every 2 years

When removing the radiator cap, be sure to stop the machine and wait until the coolant cools down.

<Procedure>

1. To drain coolant, remove the radiator cap [A], then loosen the drain valve [B].
2. Be sure to also open the drain plug [C] on the engine cylinder block for drainage.
3. Drain coolant of reserve tank.
4. When the coolant is completely drained out, close each drain valve [B] and drain plug [C], and supply new coolant from the filler port of radiator [D].
5. After changing the coolant, run the engine under unload operation for 2 to 3 minutes, then stop it. Check the coolant level again and replenish it if necessary.

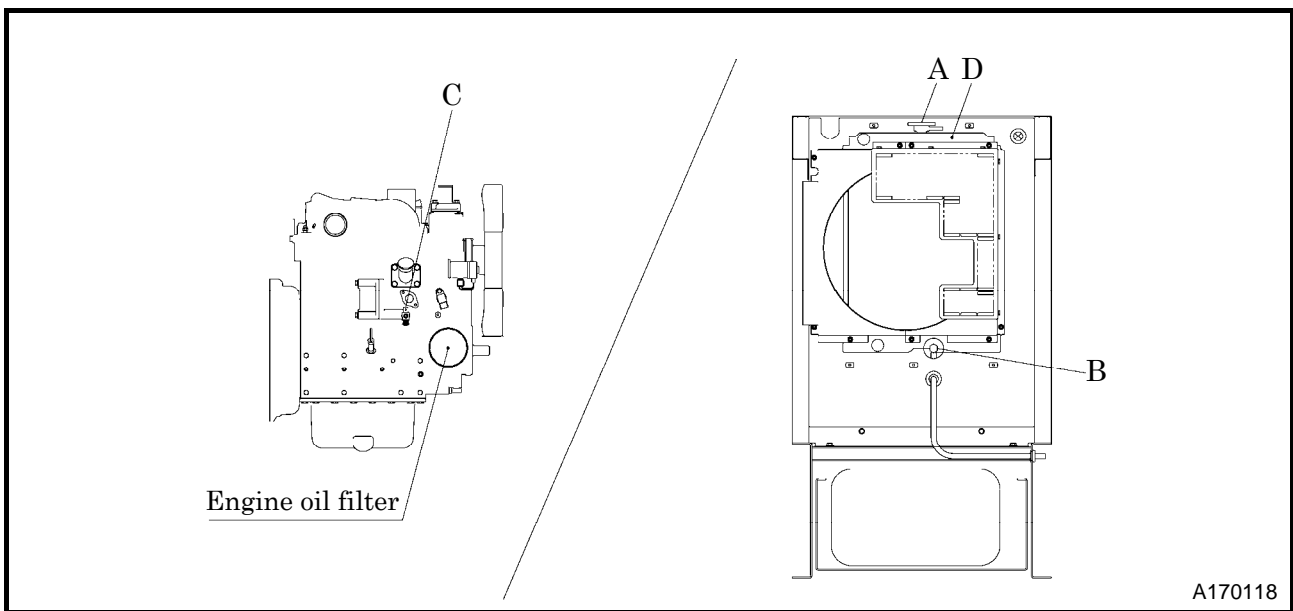

CAUTION

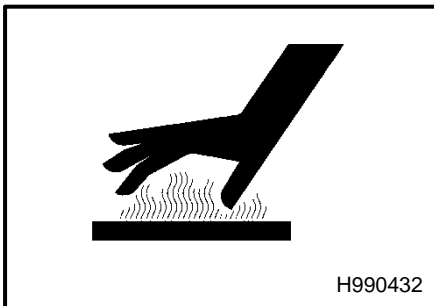

Caution in changing coolant

- Be sure to stop the machine and loosen the radiator cap slowly, after the coolant water is sufficiently cooled and the inner pressure is released, then take the cap off. If the following procedures are neglected, the radiator cap could be blown by the internal pressure or hot moisture air be blown out to cause burning. Therefore, make sure to carry out them without fail.
- LLC (Antifreeze) is a toxic material.
- When a person has drunk LLC (Antifreeze) by accident, make him vomit and make him see a doctor immediately.
- When a person gets LLC (Antifreeze) in his eyes, wash the eyes with clean running water and make him see a doctor immediately.
- When LLC (Antifreeze) is stored, put it in a container with an indication saying "LLC (Antifreeze) inside" and seal it up, then Keep it in a place away from children.
- Beware of flames.

6. Storage and Disposal

6.1 Preparation for Long-term Storage

When the machine is left unused or not operated longer than half a year (6 months), store it in a dry place free of dust after the following treatments have been done to it.

- Put the machine in an enclosure if it is stored outside. Avoid leaving the machine outside with a sheet cover directly on the paint for a long period of time, or this will cause rust to the machine.
- Perform the following treatments at least once every three months.

<Procedure>

1. Discharge existing lubricant from the engine oil pan. Pour new lubricant in the engine to clean the internals of the engine. After running it for a while, drain it again.
2. Spread lubricant on each moving part.
3. Completely charge the battery and disconnect grounding wires. Remove the battery from the machine, if possible, and store it in a dry place. (Charge the battery at least once every month.)
4. Discharge coolant and fuel from the machine.
5. Seal air-intake port of engine and other openings like the muffler with a vinyl sheet, packing tape, etc., to prevent moisture and dust from getting in the machine.
6. Measure the insulation resistance of the generator, and make sure that it is more than 1M Ohms. **(See 5.4.8)**
7. Be sure to repair any trouble and maintain the machine so that it will be ready for the next operation.

6.2 Disposal of Product

- When disposing of this machine, first drain the cooling water and oils. If you require any additional instruction or advice, contact your nearest dealer.

7. Specifications

7.1 Specifications

Model			SDG13LAX-8E1	
Generator	Exciting system		Brushless	
	Frequency		60	
	3 phase 4 wire	Rated Output	kVA (kW)	12.5 (10.0)
		Voltage	V	240
		Power Factor	%	80
		Amps	A	30
	Single-phase 3 wire	Rated Output	kVA (kW)	9.6
		Voltage	V	120-240
		Power Factor	%	100
		Amps	A	40
Engine	Model		KUBOTA D1503-M-E4	
	Type		4-cycle, water-cooled, swirl chamber type	
	No. of Cylinders		3	
	Displacement		cu.in. (liters)	91.5 (1.499)
	Output		PS(kW)	18.3 (13.7)
	Engine Speed		min ⁻¹	(1,800)
	Lubricating Oil Capacity		gal. (liters)	1.7 (6.5)
	Coolant Capacity (including radiator)		gal. (liters)	1.7 (6.5)
	Battery			80D26R (12V)
	Fuel Tank Capacity		gal. (liters)	26 (100)
Dimensions	Length		in. (mm)	55 (1,390)
	Width		in. (mm)	26 (650)
	Height		in. (mm)	46 (1,160)
	Dry Weight		lbs. (kg)	1,289 (585)
	Operating Weight		lbs. (kg)	1,499 (680)
Others	Oil Fence Capacity		gal. (liters)	13 (52)

7. Specifications

7.2 Outline drawing

[Unit : in.]

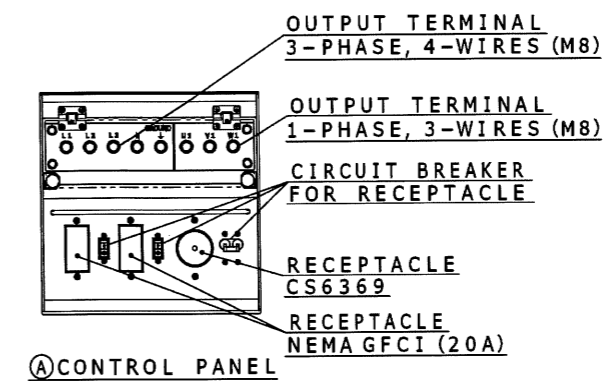
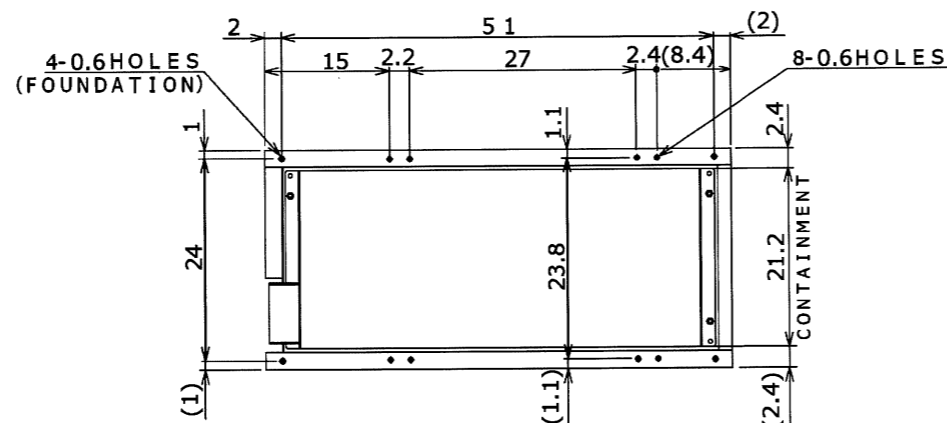
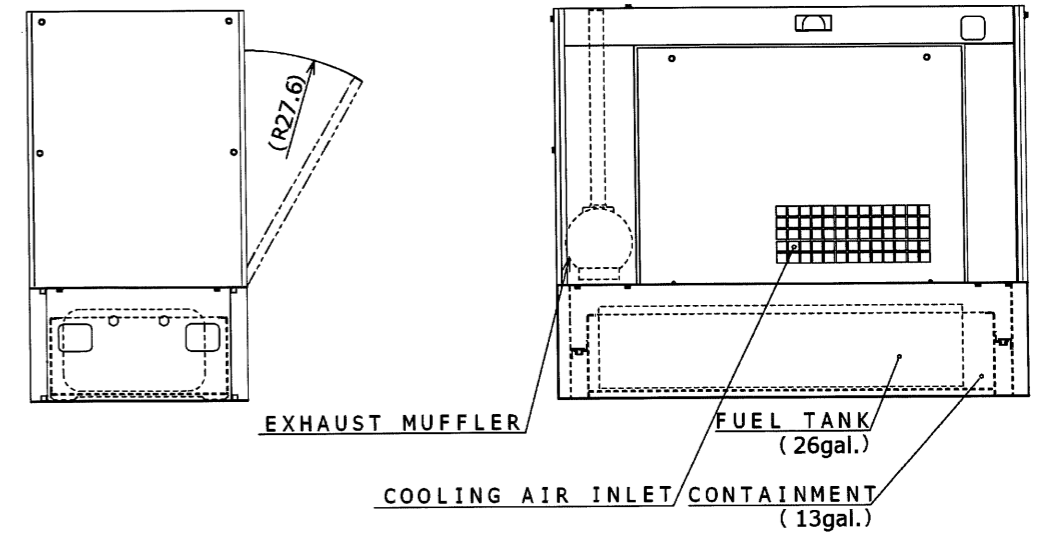
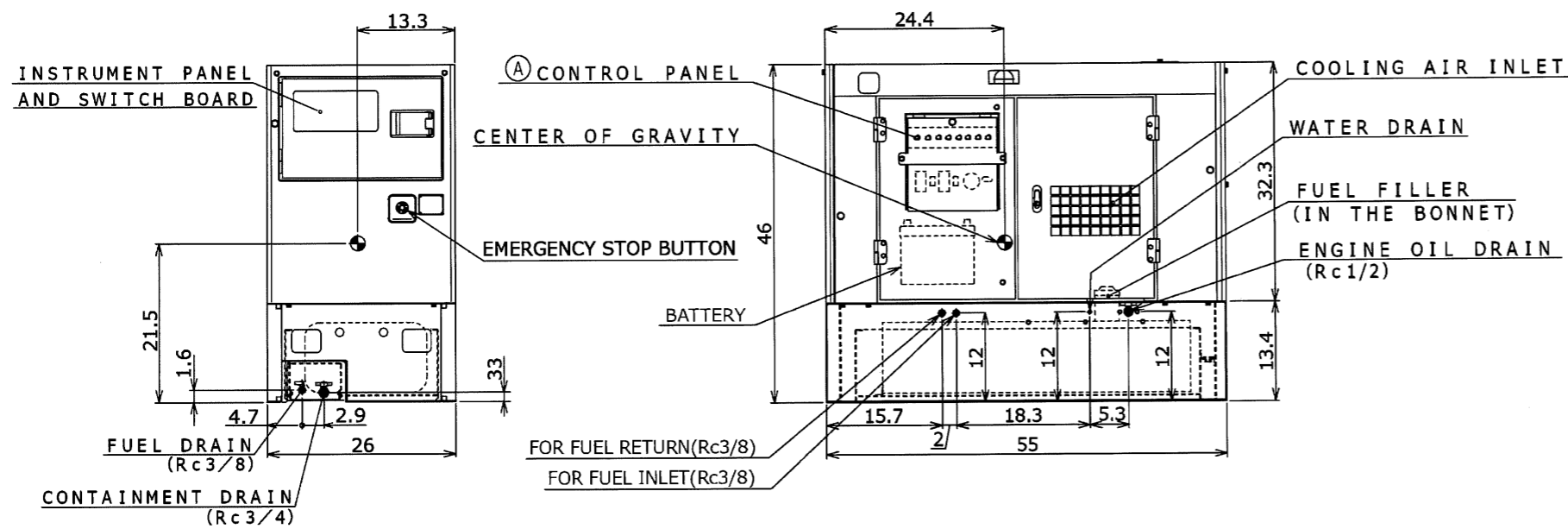
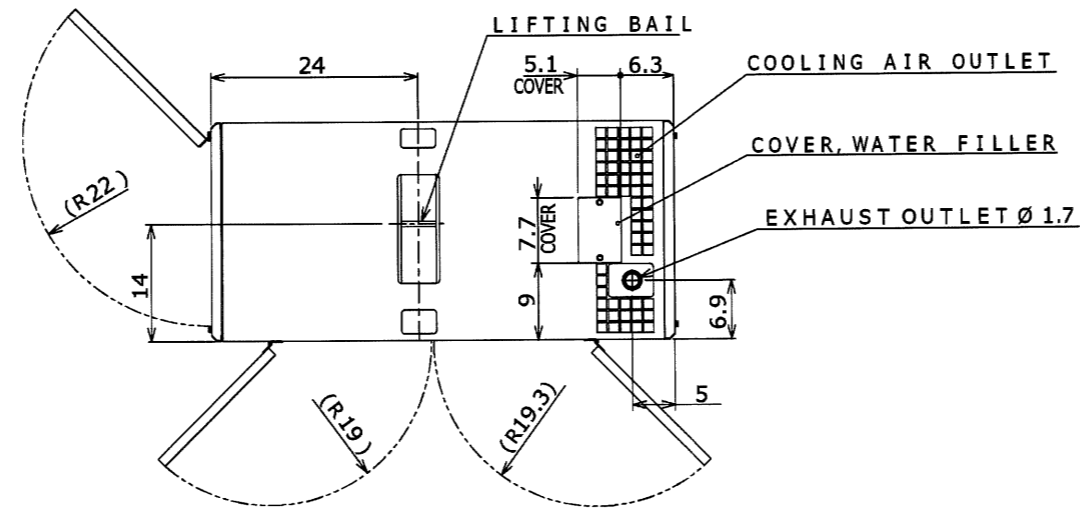

7. Specifications

[Unit : mm]

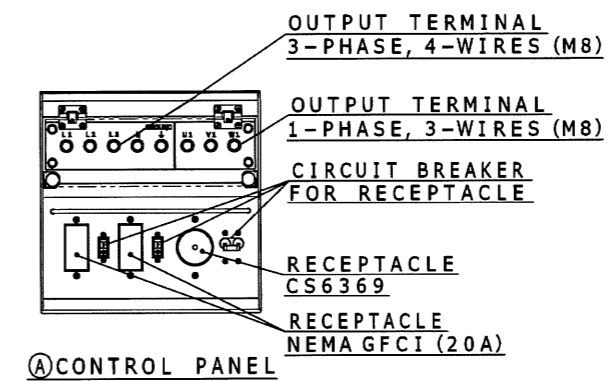
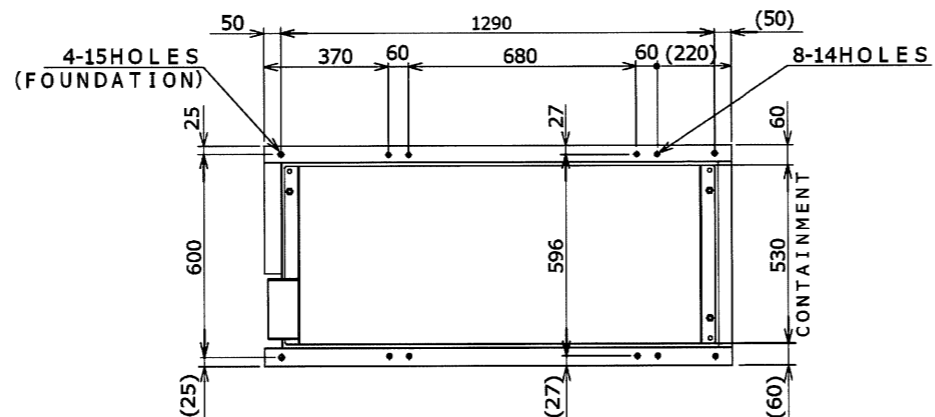
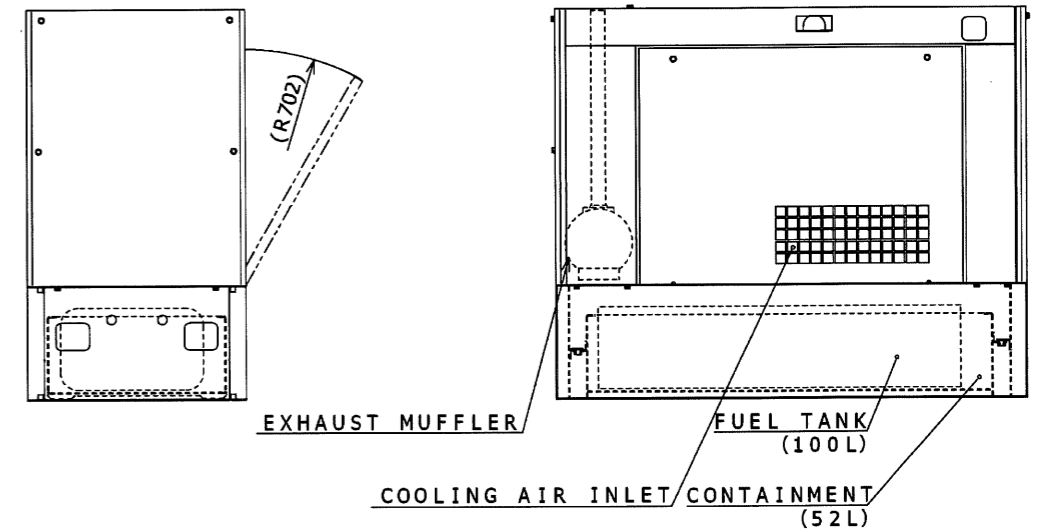
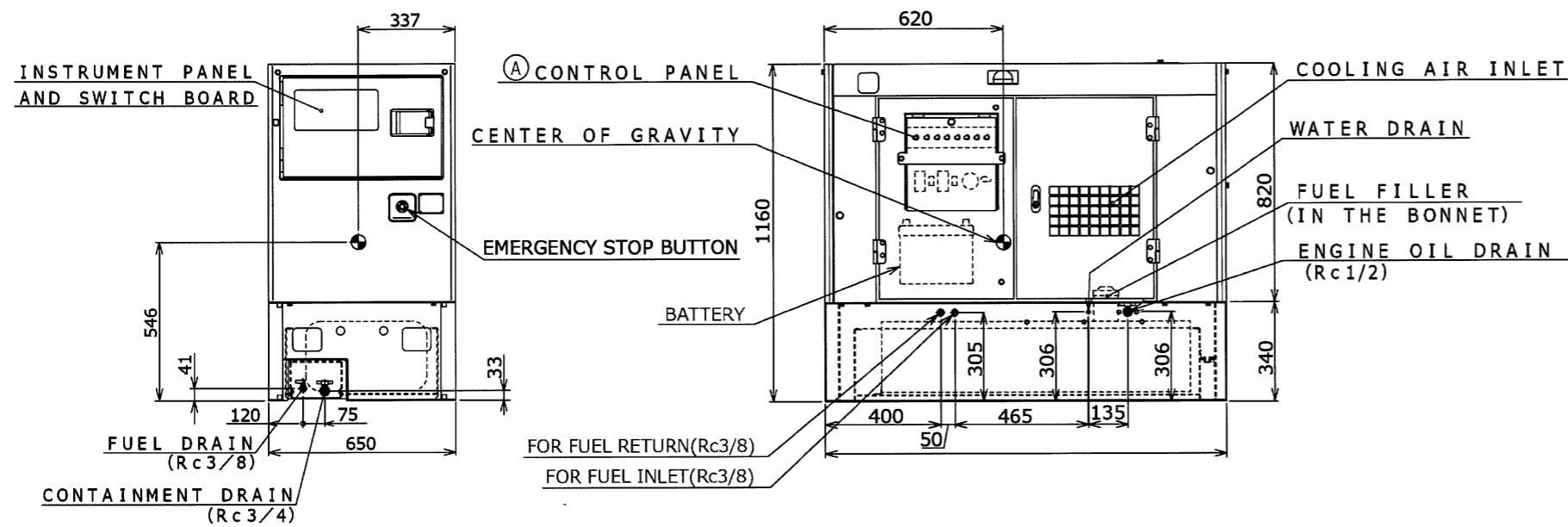
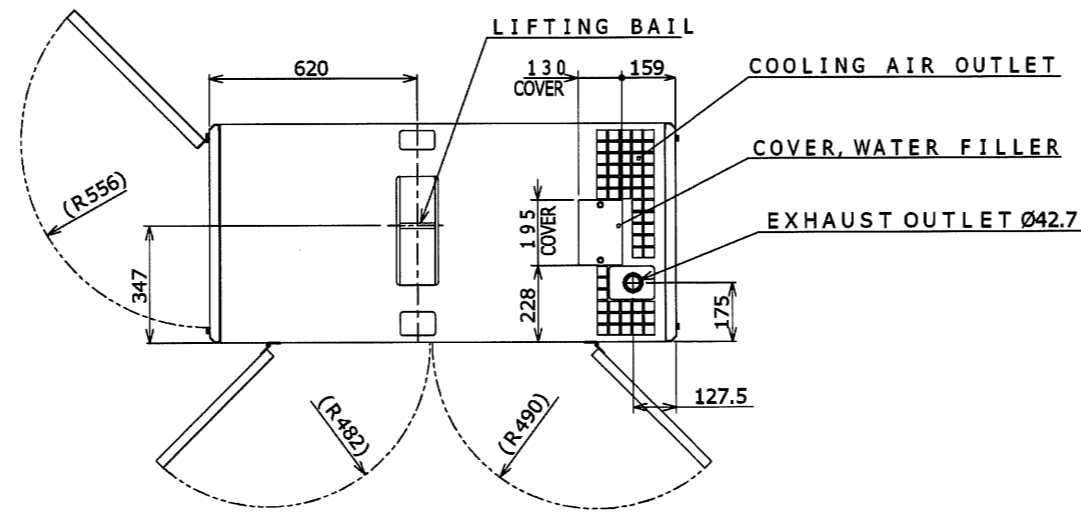

7. Specifications

7.3 Generator Wiring Diagram

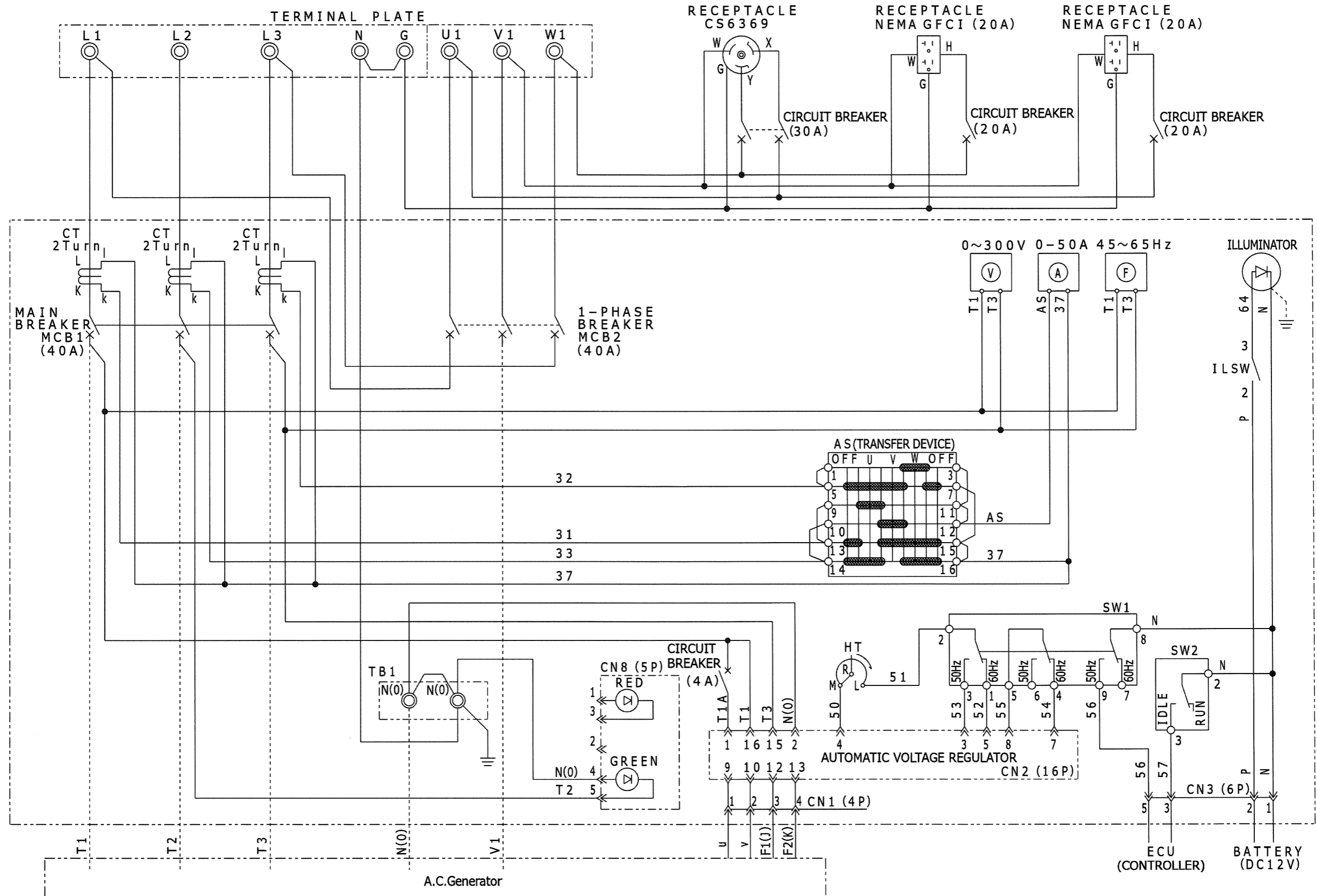

7. Specifications

7.4 Engine Wiring Diagram

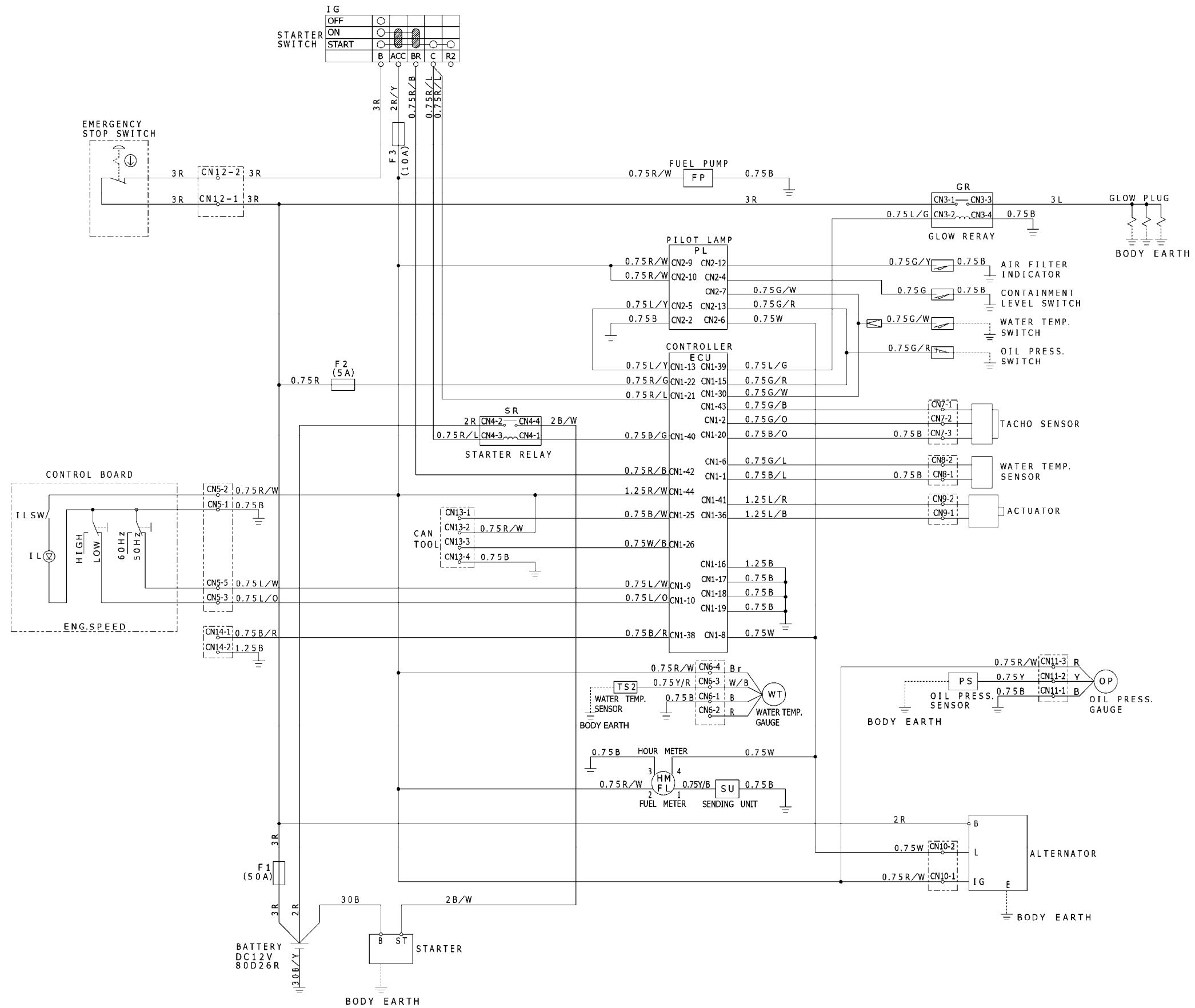

Connector terminal arrangement

The following arrangement is seen from the side of the connector inserting port.

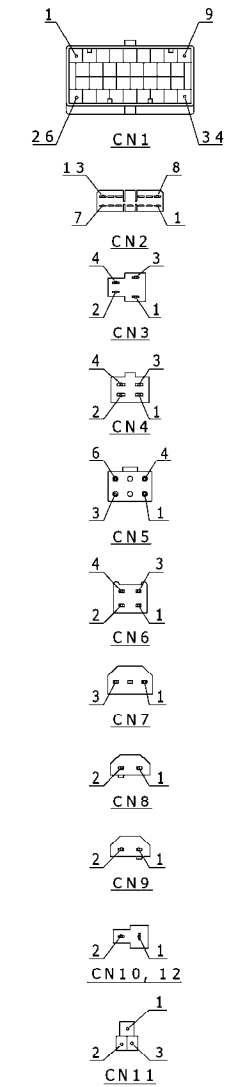

7. Specifications

7.5 Piping Diagram

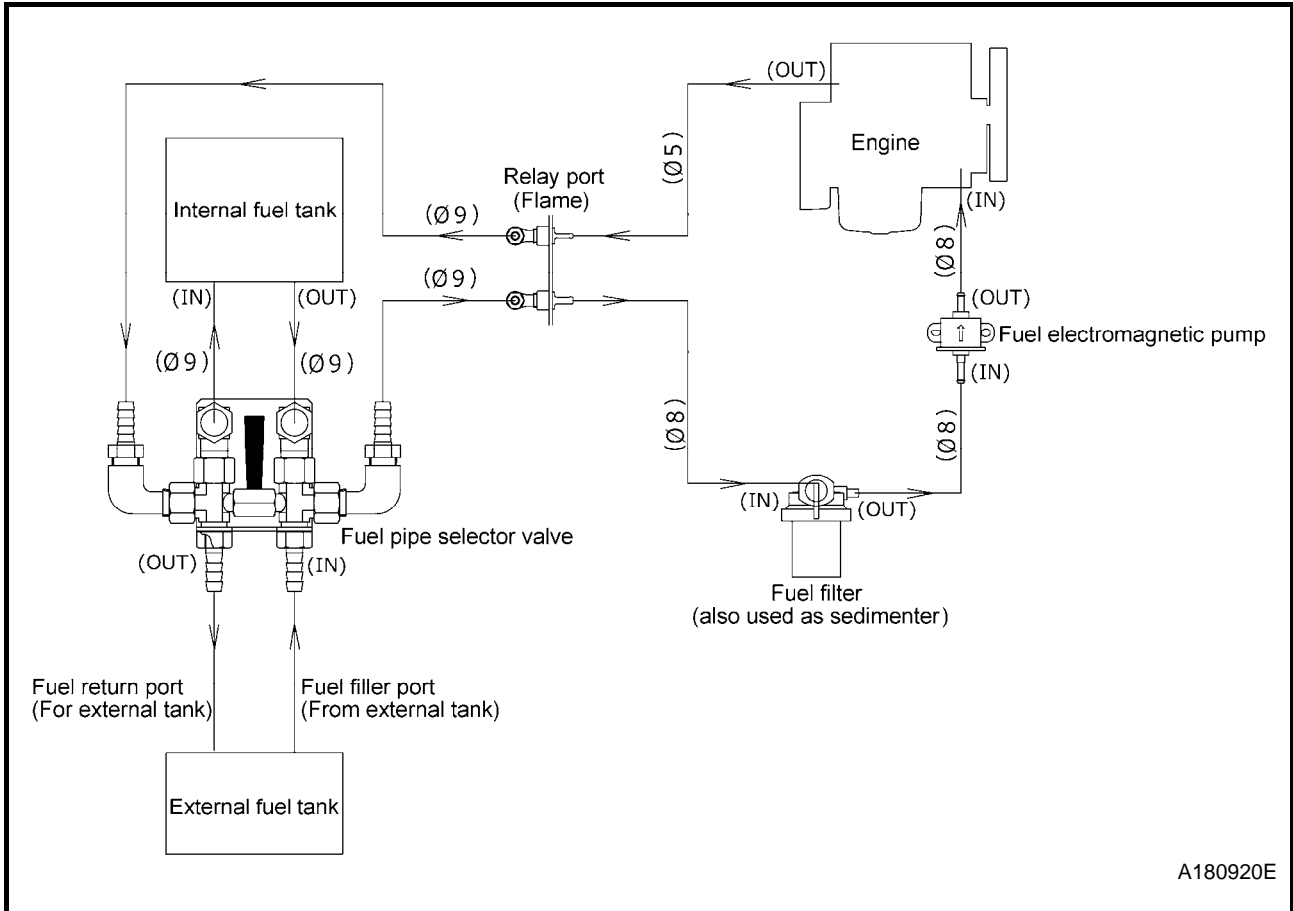

HOKUETSU INDUSTRIES CO., LTD.

8TH FLOOR SHINJUKU SAN-EI BLDG,
22-2 NISHI-SHINJUKU 1-CHOME, SHINJUKU-KU
TOKYO 160-0023 JAPAN
TEL:81-3-3348-7281
FAX:81-3-3348-7289
URL:<http://www.airman.co.jp>

Copyright (C) 2019 HOKUETSU INDUSTRIES CO., LTD. All Rights Reserved.

39600 14442
Printed JAN. 2022

AIRMAN
HOKUETSU INDUSTRIES CO., LTD.