

# AIRMAN

---

# SG

---

## INSTRUCTION MANUAL

### ENGINE GENERATOR

# SDG40S-8E1

[ENVIRONMENTAL CONTAINMENT  
BASE TANK TYPE]

Please be sure to read this manual  
before using this machine.

**HOKUETSU INDUSTRIES CO., LTD.**

# Preface

---

Thank you for choosing "AIRMAN"

- ◆ Keep this manual at hand and refer to it as necessary.
- ◆ If this manual is missing or damaged, order a new copy from our office or your nearest dealer.  
Make sure that the manual is included with the machine when it is handed over to another user.
- ◆ The contents of this manual may differ from the machine as a result of design changes. If anything is unclear or you want advisement, contact our office or your nearest dealer.
- ◆ Refer to the Engine Operation Manual for engine handling, maintenance, and safety information.

# Table of Contents

---



<b>1. Major Components</b>	<b>1-1</b>
1.1 Internal Components	1-1
<b>2. Transportation and Installation</b>	<b>2-1</b>
2.1 Transporting Machine	2-1
2.2 Conditions of Installation	2-2
2.3 Grounding	2-4
2.4 Selecting Cable	2-7
2.5 Fuel Pipe Selector Valve	2-8
<b>3. Operation</b>	<b>3-1</b>
3.1 Control Panel	3-1
3.2 Connecting Loads	3-3
3.3 Engine Oil · Coolant · Fuel	3-7
3.4 Before Starting the Unit	3-9
3.5 Operating Procedure	3-15
3.6 Emergency Stop	3-22
<b>4. Failure and Troubleshooting</b>	<b>4-1</b>
4.1 Protection device	4-1
4.2 Troubleshooting	4-3
<b>5. Periodic Inspection</b>	<b>5-1</b>
5.1 Important Items at Periodic Inspection and Maintenance	5-1
5.2 Maintenance Schedule	5-2
5.3 Periodic Replacement Parts	5-3
5.4 Maintenance Items	5-4
<b>6. Storage and Disposal</b>	<b>6-1</b>
6.1 Preparation for Long-term Storage	6-1
6.2 Disposal of Product	6-1
<b>7. Specifications</b>	<b>7-1</b>
7.1 Specifications	7-1
7.2 Outline drawing	7-2
7.3 Generator Wiring Diagram	7-4
7.4 Engine Wiring Diagram	7-5
7.5 Piping Diagram	7-7

# Safety

This section explains safety precautions for operation, inspection, maintenance, installation, movement and transportation. Read these safety requirements carefully and fully understand the contents before starting the machine.

For better understanding of the precautions in this manual and on this machine, safety precautions are classified into "DANGER", "WARNING" and "CAUTION" messages with a warning symbol  marked, according to the degree of hazard.

When one of these messages is found, please take preventive measures for safety and carry out "SAFE OPERATION AND PROPER MAINTENANCE OF THE MACHINE".

 <b>DANGER</b>	DANGER indicates an imminently hazardous situation which, if not avoided, will result in death or serious injury.
 <b>WARNING</b>	WARNING indicates a potentially hazardous situation which, if not avoided, could result in death or serious injury.
 <b>CAUTION</b>	CAUTION indicates a potentially hazardous situation which, if not avoided, may result in minor or moderate injury. It may also be used to alert against unsafe practices.
<b>IMPORTANT</b>	IMPORTANT indicates important caution messages for the performance or durability of the machine, which has no concern to injury or accident of or to a human body.

This manual does not describe all safety items. We, therefore, advise you to pay special attention to all items (even though they may not be described in the manual) for your safety.

## PROPOSITION 65 WARNING

 <b>WARNING</b>
<p>Breathing engine exhaust exposes you to chemicals known to the State of California to cause cancer and birth defects or other reproductive harm.</p> <ul style="list-style-type: none"><li>● Always start and operate the engine in a well-ventilated area.</li><li>● If in an enclosed area, vent the exhaust system.</li><li>● Do not modify or tamper with the exhaust system.</li><li>● Do not idle the engine except as necessary</li></ul> <p>For more information, go to <a href="http://www.P65warnings.ca.gov/diesel">www.P65warnings.ca.gov/diesel</a></p>

# Safety

---

- ◆ If you have any questions about the machine, please contact our office or your nearest dealer.  
Be sure to have your machine's serial number to assist in providing the correct information for you.  
A plate stamped with the model and serial number is attached to side of the machine.

ENGINE GENERATOR	
MODEL	<input type="text"/>
SER. NO.	<input type="text"/>
GEN. OUTPUT	<input type="text"/> kVA
VOLTAGE	<input type="text"/> V
FREQUENCY	<input type="text"/> Hz
POWER FACTOR	80% PHASE 3
RULE	JEM 1398
NET DRY MASS	<input type="text"/> kg
OPERATING MASS	<input type="text"/> kg
HOKUETSU INDUSTRIES CO., LTD.	
MADE IN JAPAN	

※ Each illustrated figure (Fig.) has a number (for instance, A040491) at the right bottom. This number is not a part number, but it is used only for our reference number.

A040491

# Safety

## [Safety Warning Labels]

Following labels are attached to the machine.

Keep them clean at all times. If they are damaged or missing, immediately place an order with your nearest dealer for replacement. Part numbers are indicated on the lower right corner of the label.

Adhere a new one to the original location.

1

2

3

4

5

6

7

8

9

10

11

12

13

# Safety

- The locations of the safety warning labels are as follows.

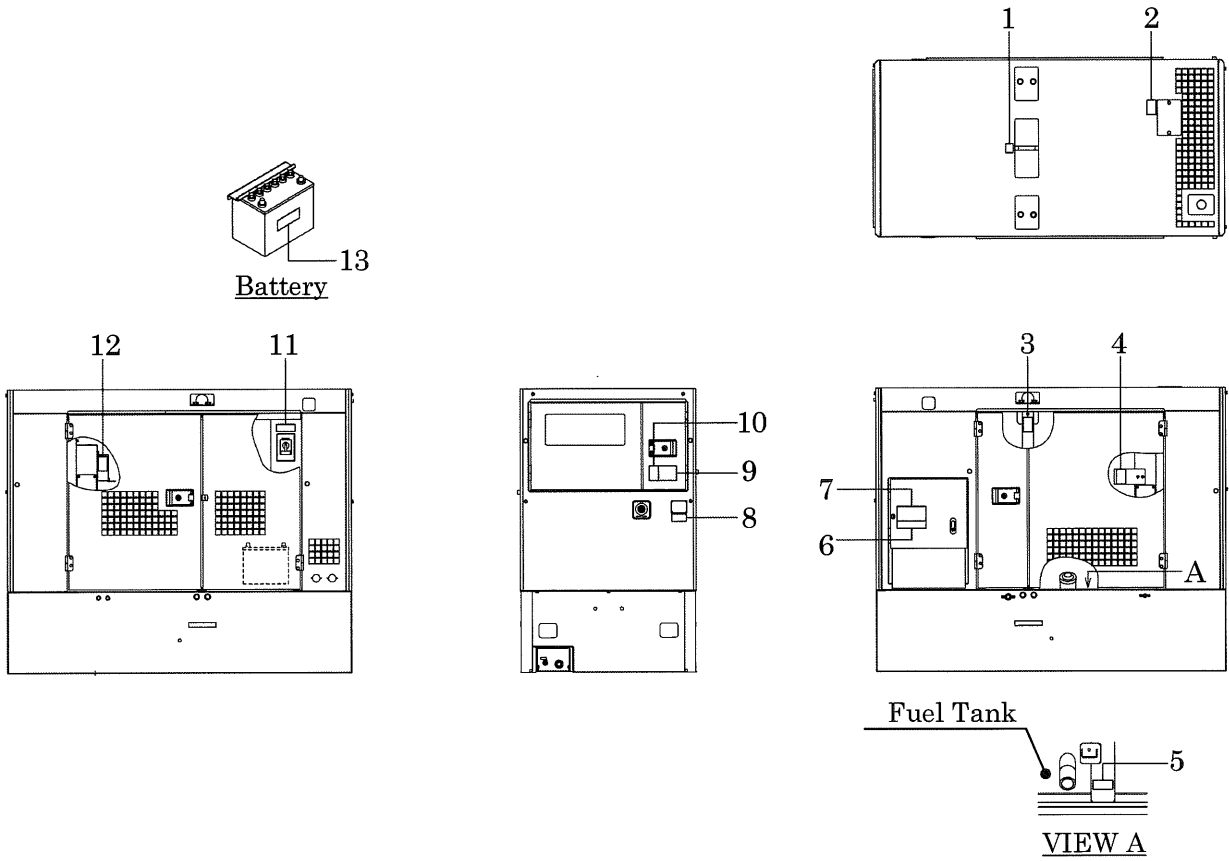

A190229

# Safety

## DANGER

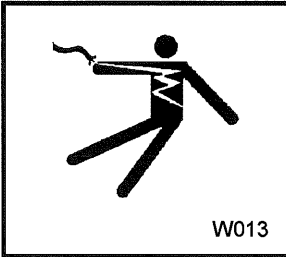

- Never touch the control panel during operation. Be aware that a voltage of several hundred volts is applied to the control panel.
- Be sure to stop the engine and turn control power switch OFF whenever the control panel has to be checked or operated. Disconnect the negative battery terminal during checking and maintenance.

## WARNING

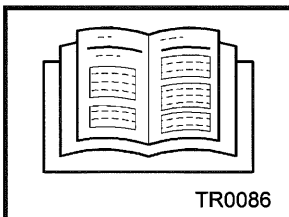

- Read each instruction plate which is displayed in the manual or on the machine carefully, understand its content and follow the indications thereof.
- Do not modify the machine without prior approval. The safety may be compromised, functions may be deteriorated, or machine life may be shortened.
- Never use the machine for the other purposes than power supply. Otherwise, serious accidents may occur.

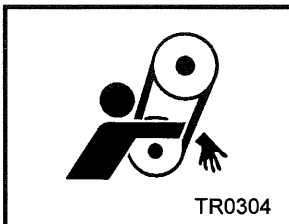

- Keep hands off from the rotating machinery or belts while running. It could cause serious injuries to hands.

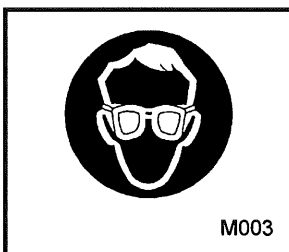

- When cleaning dust accumulated in devices such as filters, etc., with compressed air, wear safety glasses, etc. to protect your eyes



# Safety

## CAUTION



- Be sure to stop the engine and let the coolant water sufficiently cool down before draining it.
- If the drain valve is opened before the coolant water is cool enough, hot water could jet out, causing burns or scalding.

- When washing the machine, cover the control panel, generator and its electric parts to prevent them from being exposed to splashing water and avoid possible decrease in electrical insulation or other troubles to the machine.
- Dust, sand and dirt accumulated inside control panel could cause malfunction or difficulties with the instruments. Clean them using compressed air.

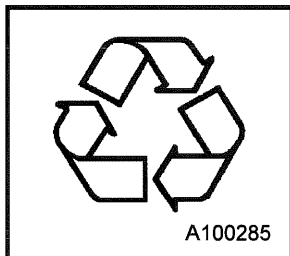

- Waste liquid from the machine contains harmful material. Do not discharge it onto the ground or into the river, lake or sea. Such material will pollute the environment.
- Be sure to use a container to hold waste liquid from the machine.
- Be sure to follow the designated regulations when disposing of oil, fuel, coolant (antifreeze), filter, battery or other harmful materials.

- The engine of this machine contains many electrical and electronic parts. Before welding, be sure to disconnect all electronic control equipment.  
Failure to do so could result in equipment malfunction due to excessive current.

# 1. Major Components

## 1.1 Internal Components

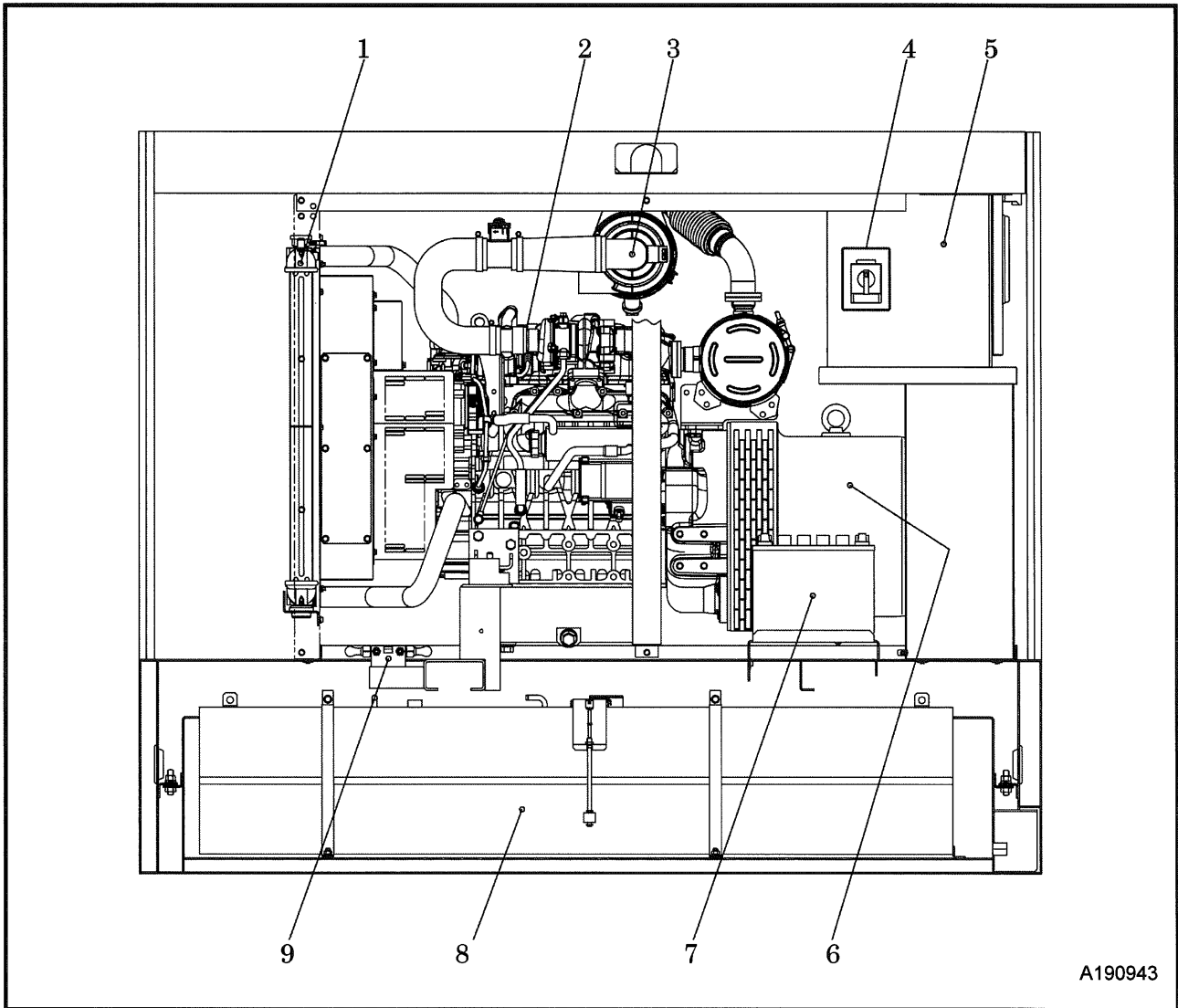

A190943

No.	Description	Function
1	Radiator	Cooling the coolant for engine in the system.
2	Engine	Driving the generator.
3	Air Filter	Filtering dust from intake air.
4	Voltage Selector Switch	Switching output voltage.
5	Control Panel	Controlling device; various meters and controls.
6	Alternator	Generating AC power to be supplied.
7	Battery	Electrically starting engine.
8	Fuel Tank	Storing fuel.
9	Fuel Pipe Selector Valve	Switching to supply fuel from outer tank.

# 1. Major Components

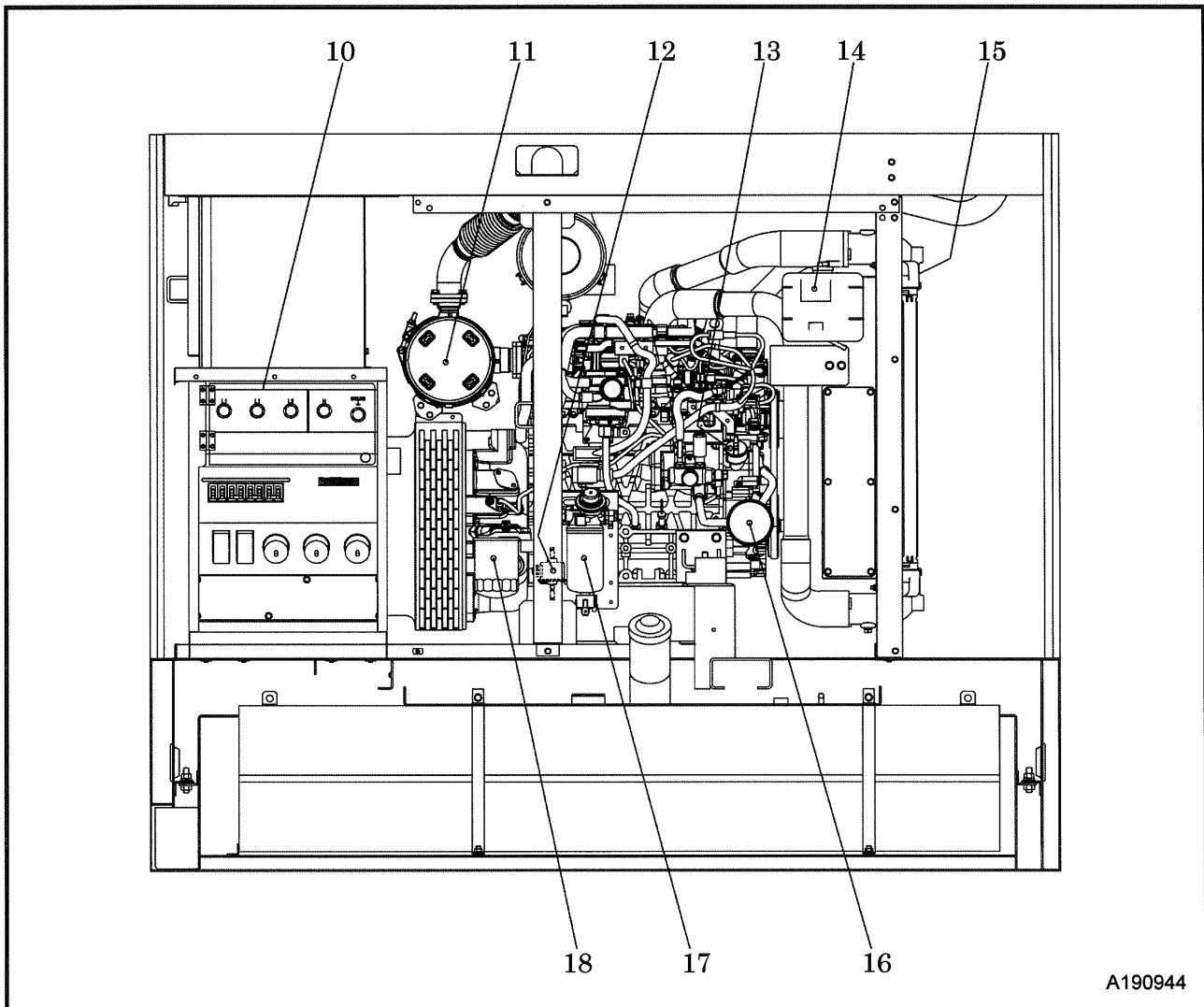

A190944

No.	Description	Function
10	Terminal Board	Outlet port for AC power.
11	DOC(Diesel Oxidation Catalyst)	Catalyst for oxidizing exhaust gas.
12	Fuel air-bleeding electromagnetic pump	Automatically bleeding air from fuel pipes.
13	Engine Oil Filler Port	Supplying and replenishing engine oil to engine.
14	Reserve tank	Checking coolant level and supplying it.
15	Intercooler	Cooling the air compressed by engine supercharger.
16	Engine Oil Filter	Filtering engine oil in the system.
17	Fuel Pre-Filter	Removing dust and water mixed in fuel.
18	Fuel Filter	Filtering foreign matter and dust mixed in fuel.

# 2. Transportation and Installation

## 2.1 Transporting Machine

When loading and unloading machine, be sure to use the lifting bail provided on the center of the machine top.

### 2.1.1 Lifting

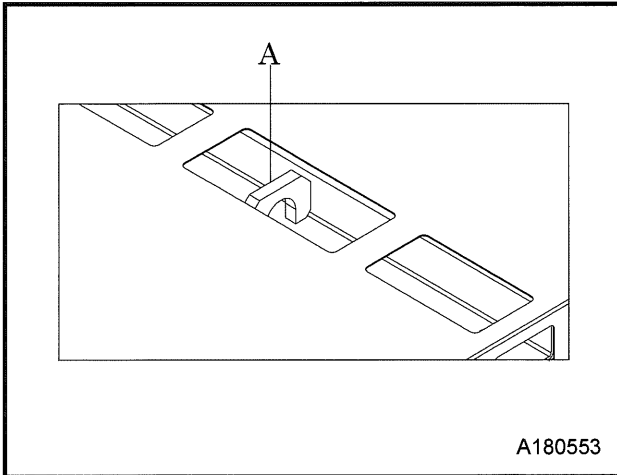

<Procedure>

1. Before lifting the unit up, make sure to check the lifting bail [A] for any cracks or loosened bolts.
  2. Connect the hook of the crane or shackle with lifting bail fitted at the top center of the unit, and make sure that there is no person standing around the unit. Then perform hoisting operation.
- Select an appropriate crane or truck by referring to the mass and dimensions mentioned in "Specifications".
  - Only a qualified crane operator is allowed to operate a crane.



**WARNING**

**Transportation**

- Never go underneath the unit when suspended because it is very dangerous.
- Do not lift the unit while it is running. Otherwise, a fatal or serious accident may occur.



**CAUTION**

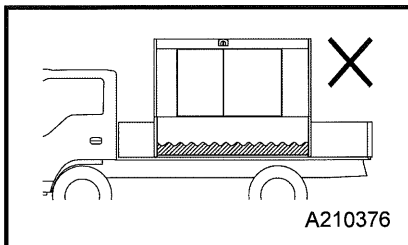

- Before transporting, check if there is condensate (fuel, oil and coolant) inside the oil fence, and if so drain it. (See 3.4.9)
- When transporting with condensate (fuel, oil and coolant) accumulated inside the oil fence, the condensate may flow out of the machine.

# 2. Transportation and Installation

## 2.2 Conditions of Installation

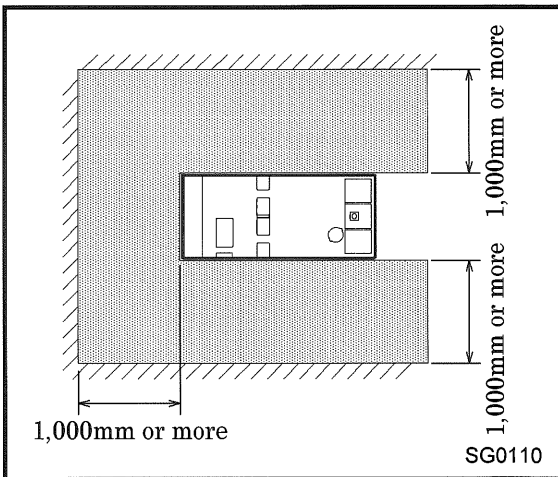

This machine should be installed only on a dry, level surface and operated in an appropriate environment as below:

- Ambient temp: 5°F to 104°F (-15°C to 40°C)
- Humidity: Less than 85%
- Altitude: Lower than 1,000m above sea level.
- ※Using the machine outside the above conditions may cause serious failure.
- If more than two units are placed parallel in operation, keep enough distance so that exhaust air from the one does not affect the other one.
- Keep enough space around the unit for inspection and maintenance access.

### WARNING

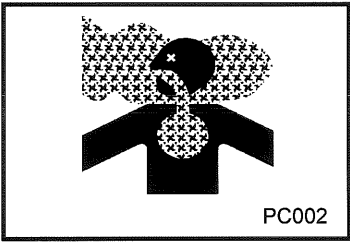

- Exhaust gas from the engine is poisonous, and it could cause death or injury if inhaled. Avoid using the machine in an insufficiently ventilated building or a tunnel.
- Do not position the exhaust gas outlet in the direction of a person or a house.

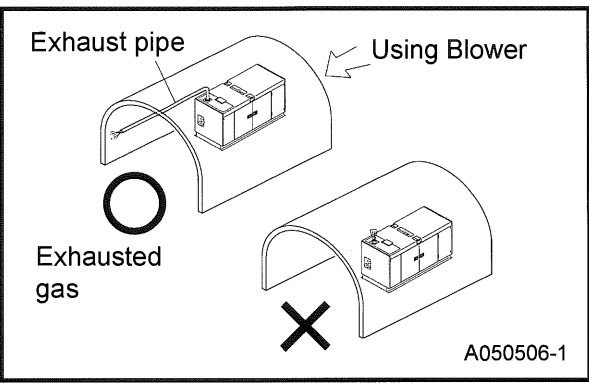

- If the unit is installed inside any tunnel, make sure to provide fresh air and ventilate it.
- In this case, make sure to extend the exhaust fume pipe outdoors, and also make sure to prevent any leak from any connection pipes.

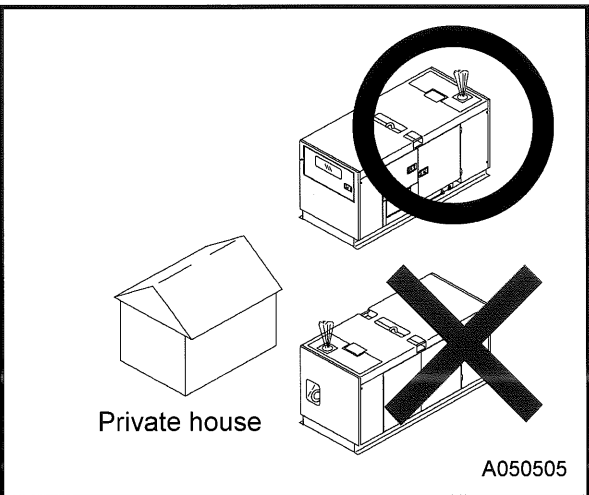

- Never locate the unit with the exhaust muffler facing any private house.
- As the exhaust gas from the engine is poisonous, never direct it at other persons.

## 2. Transportation and Installation

### WARNING

In case that the machine is installed indoors

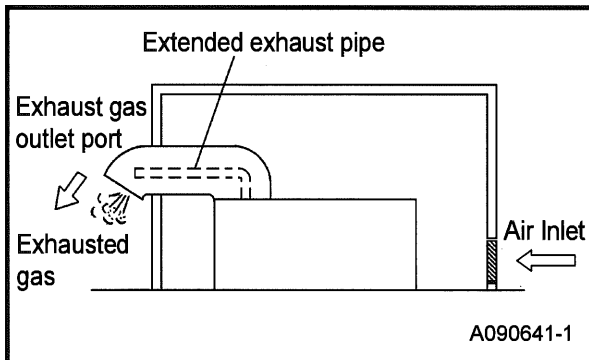

- In case that the unit is installed indoors for operation, suction air port and exhaust fume outlet port should be provided for better air ventilation.
- Make sure to secure enough space in front of air suction port and to secure it after exhaust fume outlet port so that the engine will not get overheated.
- An exhaust pipe or the like should be provided at the exhaust outlet port so as to send exhaust fumes outdoors.
- The cooling air outlet port of radiator should have access to the outdoors through a duct or the like for air ventilation.

### CAUTION

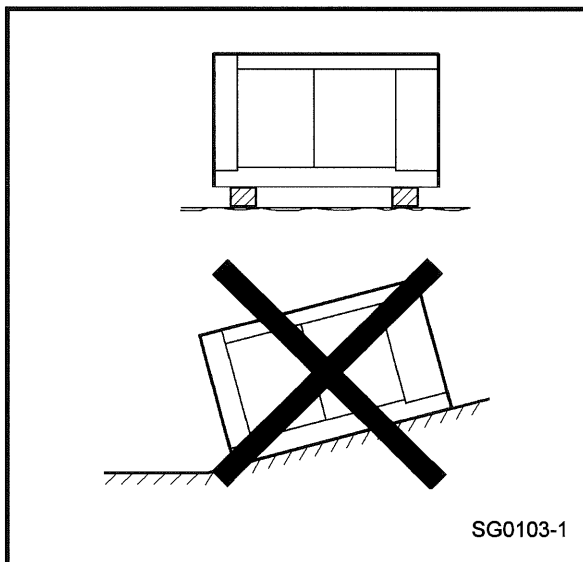

- The unit should be installed within 5° degree inclination.
- If installation site is not flat, put square bar under the unit so as to install it horizontally.
- Avoid installing the unit in a damp place or a place where water collects. Such an installation could cause electric shock.
- When installing the unit at the sea shore, make sure that it is not exposed directly to sea water because there is a risk of the change to the insulation resistance of the generator assembly or control panel inside. To request a model with measures against salt damage, please consult the nearest sales office.
- When installing the unit at a sandy place, make sure that exhaust from the generator or radiator does not blow the sand up in the air or into the machine.

Safety Fence

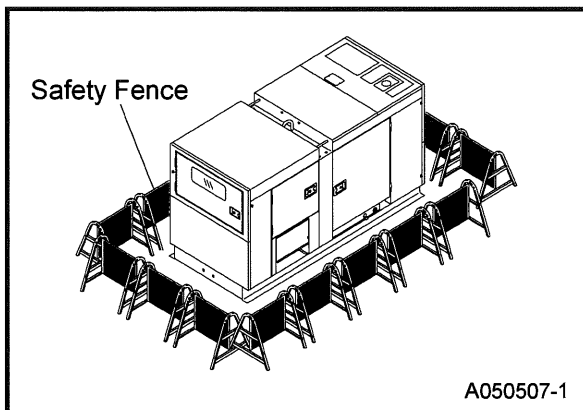

- In order to prevent from any persons other than those engaged in the job site from using or interacting with the machine, please prepare for safety fences around the unit.

## 2. Transportation and Installation

### 2.3 Grounding

#### 2.3.1 Ground Terminal

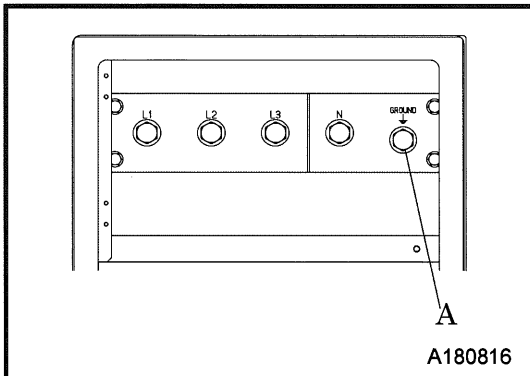

- The ground terminal [A] on the AC output terminal board is connected to the earth ground of this unit and to the earth terminal of each outlet.

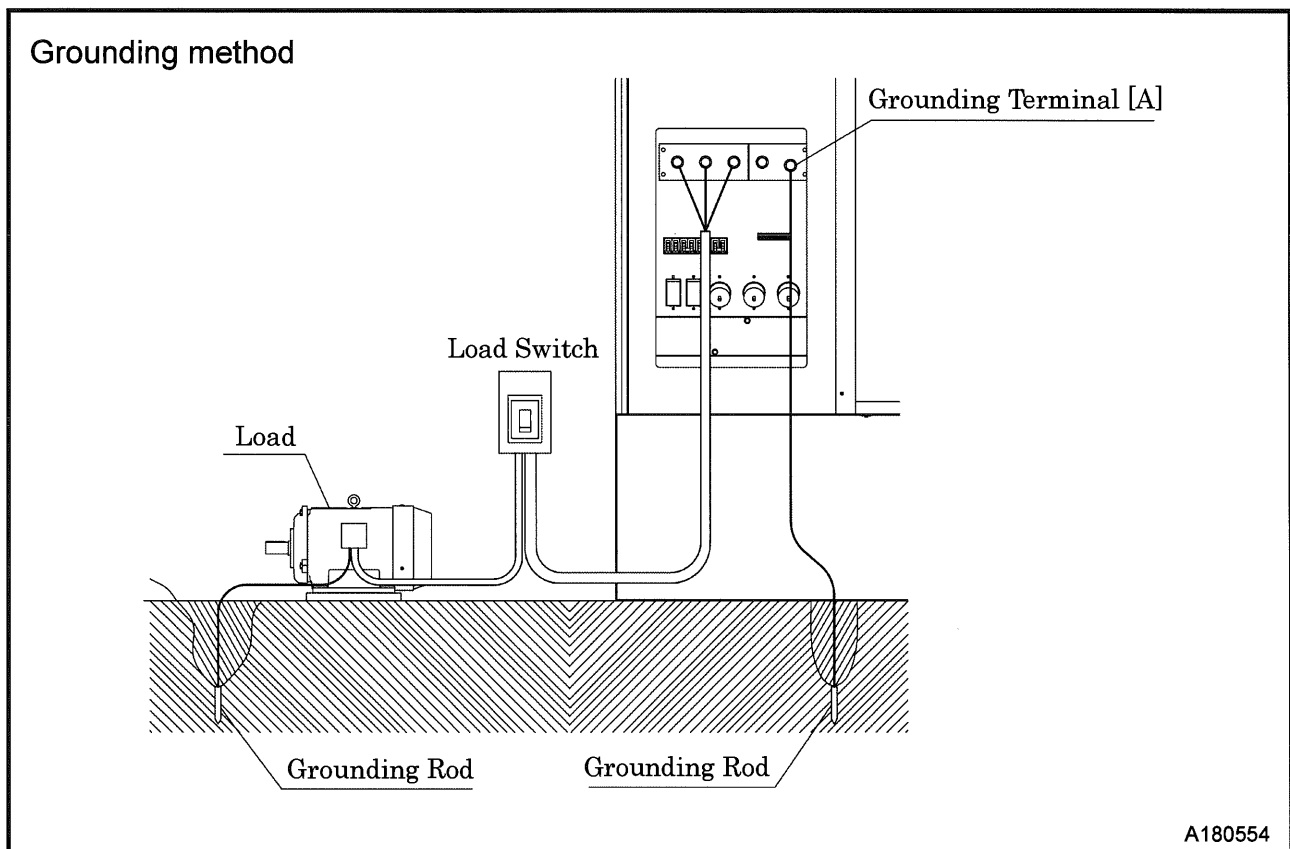

#### 2.3.2 Grounding System

AIRMAN's generators have a system ground that connects generator frame components to the ground terminals in the AC output receptacles. The AC neutral wire (N) is connected to the system ground.

## 2. Transportation and Installation

### 2.3.3 GFCI Receptacles

- All of the 20 ampere 120 volt receptacles on the generator are protected by a GFCI (Ground-fault circuit interrupter) for protection against the hazards of ground fault currents. An example of ground-fault current is the current which would flow through a person who is using an appliance with faulty insulation and, at the same time, is in contact with an electrical ground such as a plumbing fixture, wet floor, or earth.
- The ground-fault circuit interrupter will not protect against short circuits or overloads. The circuit breaker in the control panel which supplies power to the circuit provides that protection.
- The ground-fault circuit interrupter can be identified by the TEST and RESET buttons. The receptacles on the GFCI can be tested with the TEST and RESET buttons.

TEST BUTTON: To test, depress the "TEST" button. (Power is turned off)

RESET BUTTON: To restore power, depress the "RESET" button.

- Perform this test monthly or every 250 hours operation, whichever comes first, in order to ensure proper operation of the GFCI receptacle.

If the generator is stored outdoors, unprotected from the weather, test the GFCI receptacle before each use. Record your test on the GFCI test card provided on the control panel.

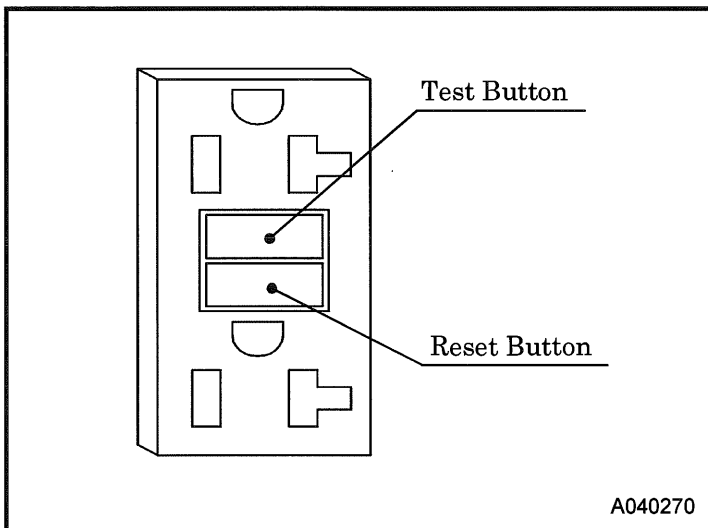

#### CAUTION

- Using the generator in rain, snow or near water can lead to death from electric shock.



## 2. Transportation and Installation

---

### 2.3.4 Connections to a Building's Electrical System

Connections for standby power to a building's electrical system must be made by a qualified electrician. The connection must isolate the generator power from utility power and must comply with all applicable laws and electrical codes.

#### CAUTION

- Improper connections to a building's electrical system can allow electrical current from the generator to backfeed into the utility lines. Such backfeed may electrocute utility company workers or others who are in contact with the lines during a power outage. Consult the utility company or a qualified electrician.
- Improper connections to a building's electrical system can allow electrical current from the utility company to backfeed into the generator. When utility power is restored, the generator may explode, burn, or cause a fire in the building's electrical system.

# 2. Transportation and Installation

## 2.4 Selecting Cable

- Select a cable with sufficient diameter by considering the permissible current on the cable and the distance from the generator to the load.
- If the current flowing to the load exceeds the permissible current of the cable, resultant overheating may burn the cable. Similarly, if the cable is too small in thickness to the length, the input voltage to the load will fall to cause the load input power to drop, as a result, the performance of the machine cannot be displayed.

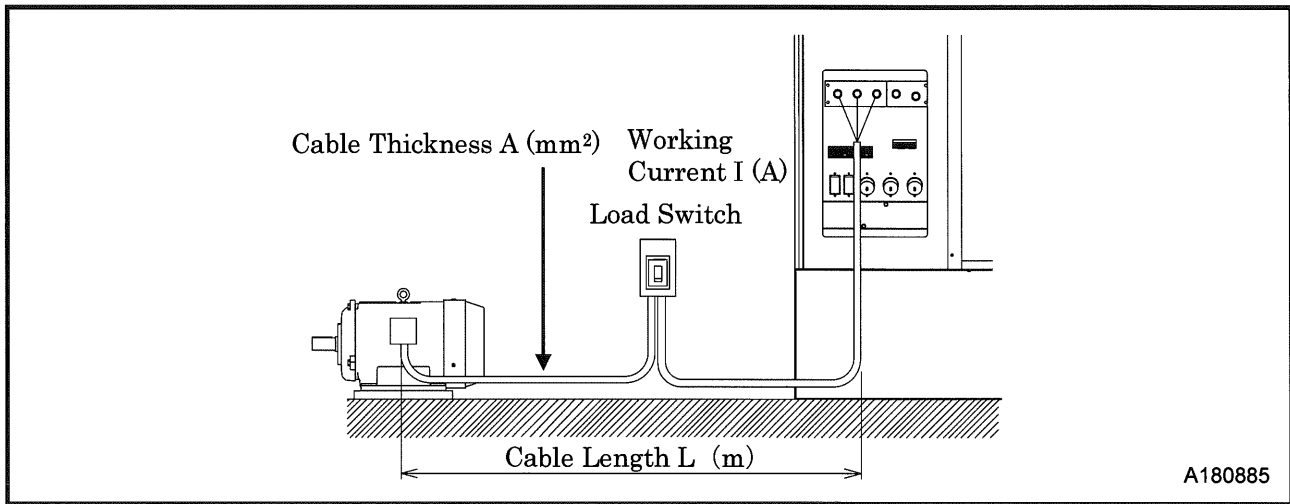

A180885

- Simplified formula to seek voltage drop or cross-sectional area of the cable from cable length and working current.  
Select such a cable length and thickness so that the voltage drop will remain within 5%.

Output System	Voltage Drop	Cross-sectional area of Cable	e: Voltage drop(V) e': Voltage drop between outside line or one line of each phase and neutral line. A: Cable thickness (mm <sup>2</sup> ) L: Cable length (m) I: Working current (A)
3 Phase, 3 Wire	$e = \frac{30.8 \times L \times I}{1,000 \times A}$	$A = \frac{30.8 \times L \times I}{1,000 \times e}$	
3 Phase, 4 Wire	$e' = \frac{17.8 \times L \times I}{1,000 \times A}$	$A = \frac{17.8 \times L \times I}{1,000 \times e'}$	

- The following tables show the relations between the cable length and the cable thickness (nominal cross-sectional area) suited to the working current.  
(Based on the condition that working voltage is 200 V, with voltage drop of 10V.)

Single-Conductor Cable

(Unit: mm<sup>2</sup>)

Length Current	165ft (50m)	246ft (75m)	328ft (100m)	410ft (125m)	492ft (150m)	656ft (200m)
50A	8	14	22	22	30	38
100A	22	30	38	50	50	60
150A	38	38	50	60	80	100

Three-Conductor Cable

(Unit: mm<sup>2</sup>)

Length Current	165ft (50m)	246ft (75m)	328ft (100m)	410ft (125m)	492ft (150m)	656ft (200m)
50A	14	14	22	22	30	38
100A	38	38	38	50	50	60
150A	22×2	22×2	38×2	38×2	38×2	50×2

# 2. Transportation and Installation

## 2.5 Fuel Pipe Selector Valve

### 2.5.1 Overview

This valve is designed to feed fuel directly from an external fuel tank or from the installed fuel tank as described below.

### 2.5.2 Operation method

<Procedures>

1. Machine is delivered from factory with fuel line piping and selector valves built in as shown in the following Fig.1. When operating a machine, using installed fuel tank, run the machine with the fuel line piping and the handles of selector valves factory-arranged.
2. When using a separate storage tank, remove the plug fitted at the connections to the separator tank and make piping as shown in Fig.2. And then turn the handles of the selector valve as shown in Fig.2.
3. When removing the piping connection, make sure to return the handles to the original positions shown in Fig.1 and install the plugs.

### 2.5.3 Installation of Separate Storage Fuel tank and piping method

<Procedures>

1. Use oil resistant hoses with an inside diameter of 8mm to 10mm.
2. Install the fuel tank so that the fuel level of the tank is between 0 and 2.5m high from the machine installation level.
3. In order to avoid suction of water and sediment together, install the suction pipe so that the inlet port of suction pipe may be kept between 15mm and 20mm higher than the bottom line of the tank. Also install the outlet port of the return pipe inside the tank. (See Fig.2·A)
4. When refilling fuel in the tank, take great care to not allow water and sediment in.

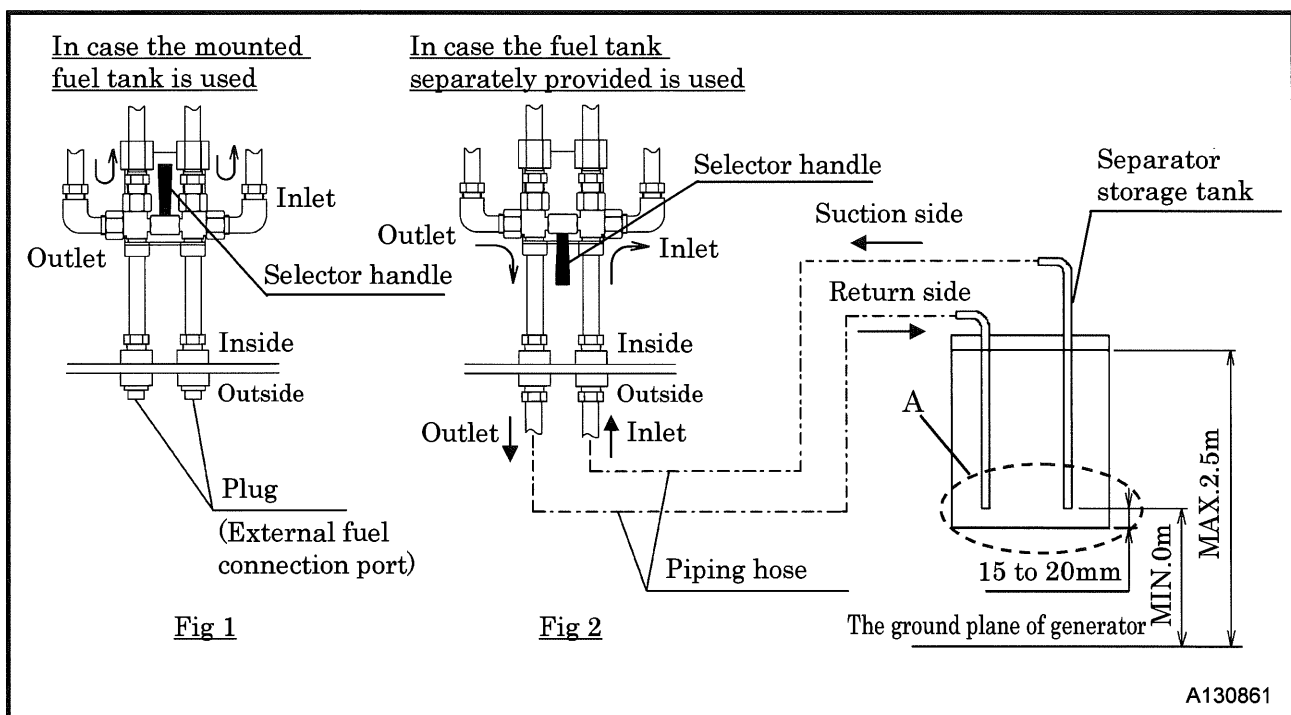

## 2. Transportation and Installation

---

**CAUTION**

- Always keep watching the fuel feeding conditions while feeding fuel from the external fuel storage tank.
- Make sure to change the handles of the selector valves to the predetermined positions.  
If you make a mistake in turning the handles, it can burst the fuel pipe and cause overflowing. It could lead to a serious accident.
- Do not use excessive force to the selector valve handle. It could cause damage or fuel leakage.

# 3. Operation

## 3.1 Control Panel

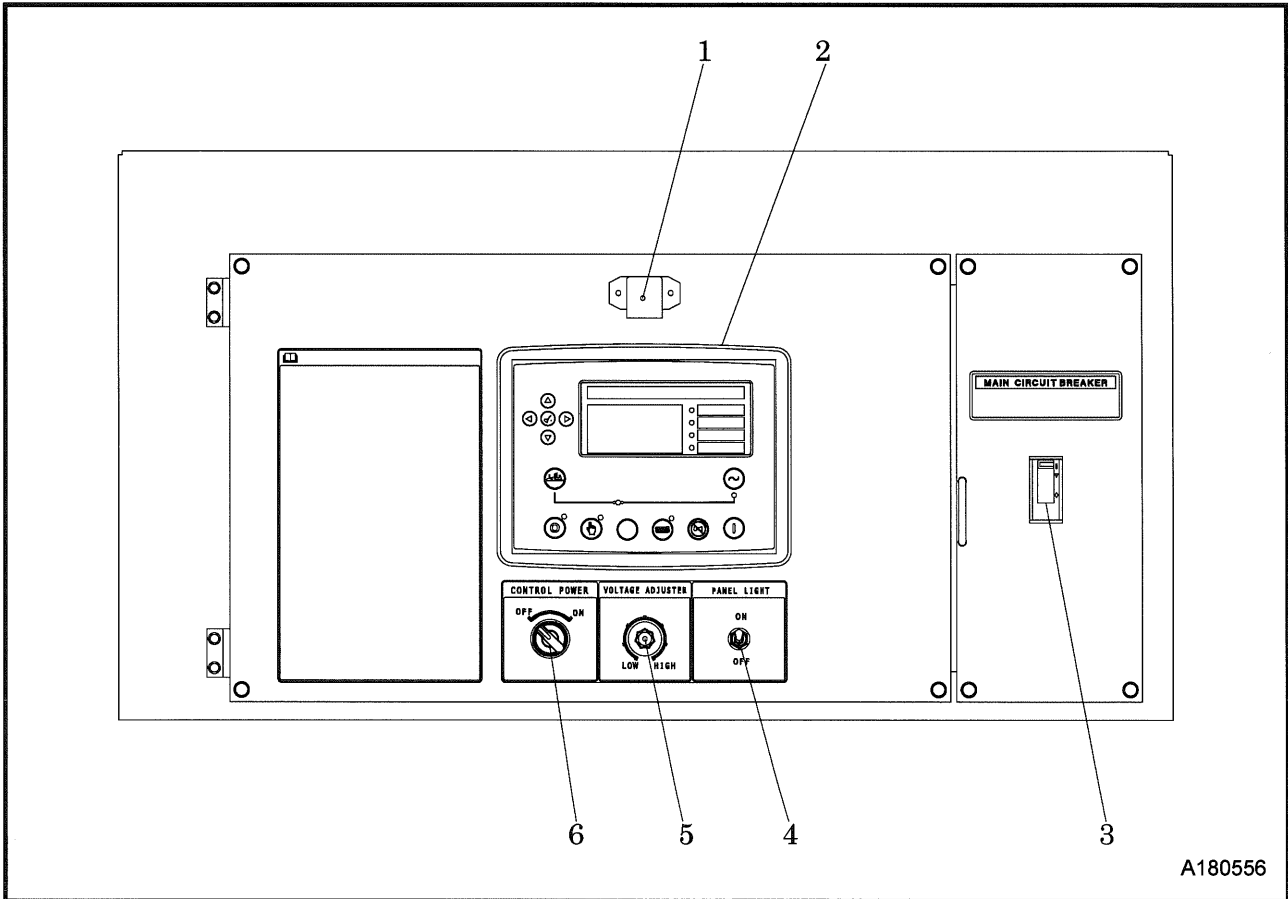

A180556

- |                    |                         |
|--------------------|-------------------------|
| 1. Panel light     | 4. Panel Light Switch   |
| 2. Control Panel   | 5. Voltage Adjuster     |
| 3. Circuit Breaker | 6. Control Power Switch |

# 3. Operation

## Control Panel

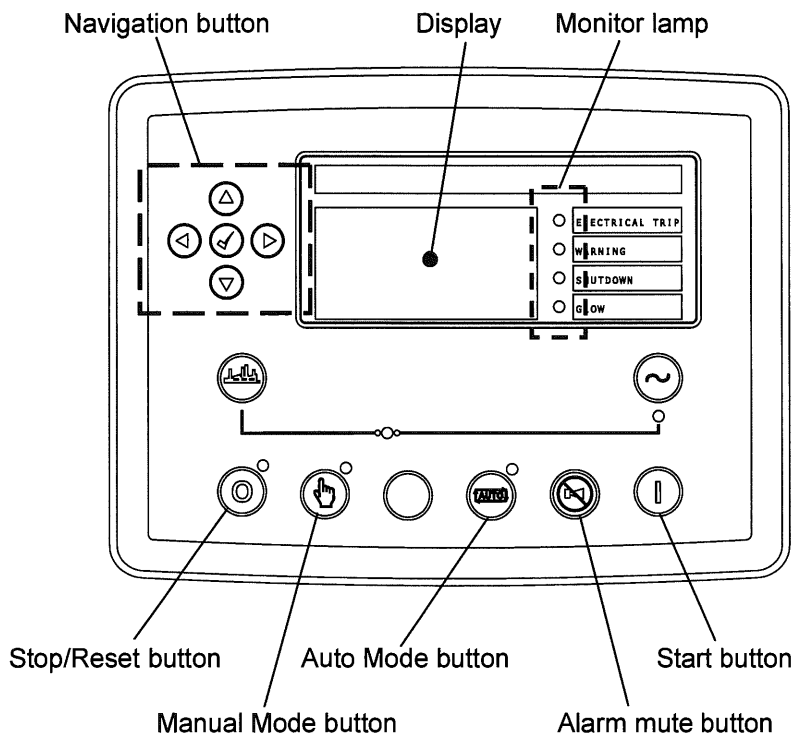

A180097E

[How to switch monitor]

1. Items shown below can be selected by pressing ◀ or ▶ button.

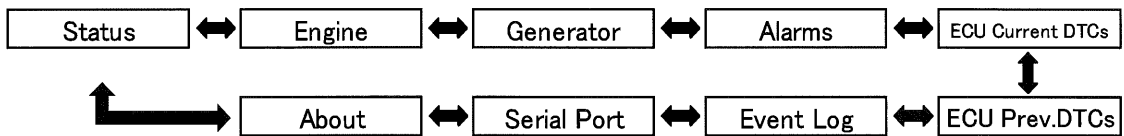

2. Parameters within an item can be viewed by pressing ▲ and ▼ button.

3. Monitor will return to main screen if no commands are entered for 3 minutes.

# 3. Operation

## 3.2 Connecting Loads

Select a cable with sufficient diameter by considering the load capacity and the distance from the generator to the load. Use terminals for connection and securely fasten them. (See 2.4)

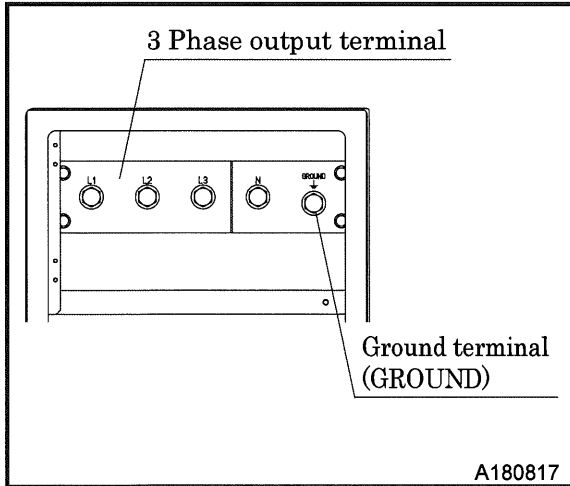

- After checking phase number and voltage of the load, make sure to connect them correctly.

---Terminal Size---

3 Phase output (L1,L2,L3,N)	M14
Ground terminal (G)	M14

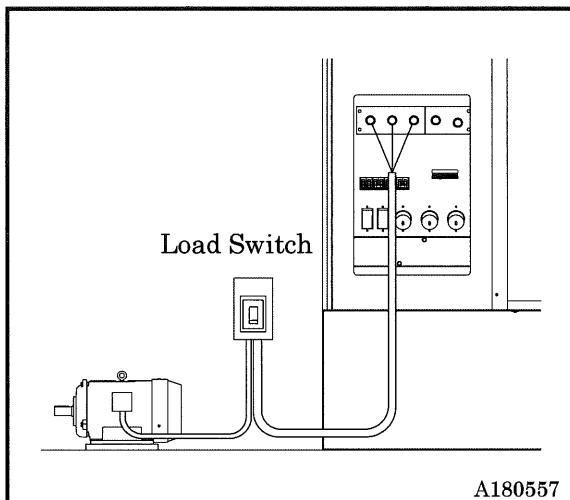

- Install a load switch between the output terminal and the load to switch on/off the load. Do not switch the load on/off directly by the circuit-breaker of the generator. It could cause damage to the circuit-breaker.
- Connect the connecting cable to the load so that the output terminals should not touch each other.

**WARNING**

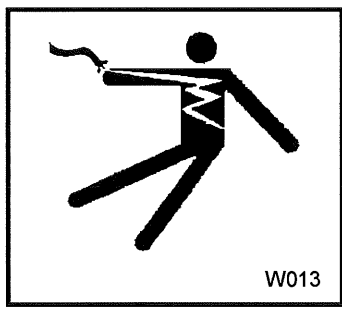

- When removing or connecting a connecting cable for changing load, be sure to switch OFF the circuit breaker, and then carry out a work. The operator must keep the key during operation.
- For a connecting cable to load, do not use a cable with damaged sheath nor an inappropriate insulation cable to the voltage. Secure connections between each cable terminal and input/output terminal. Otherwise, it may be slackened during operation and may cause a fire or an electric shock accident.

# 3. Operation

## 3.2.1 Output Terminal connections

Voltage can be selected with voltage selector switch.

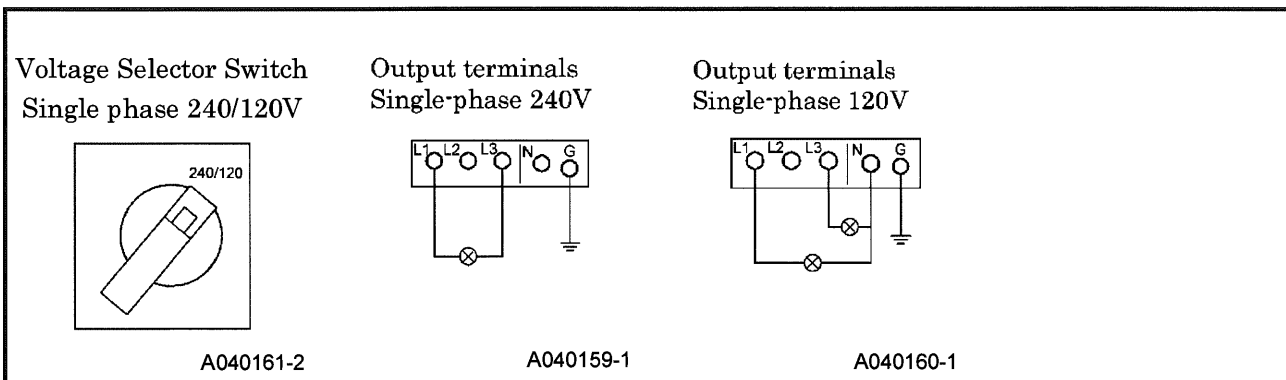
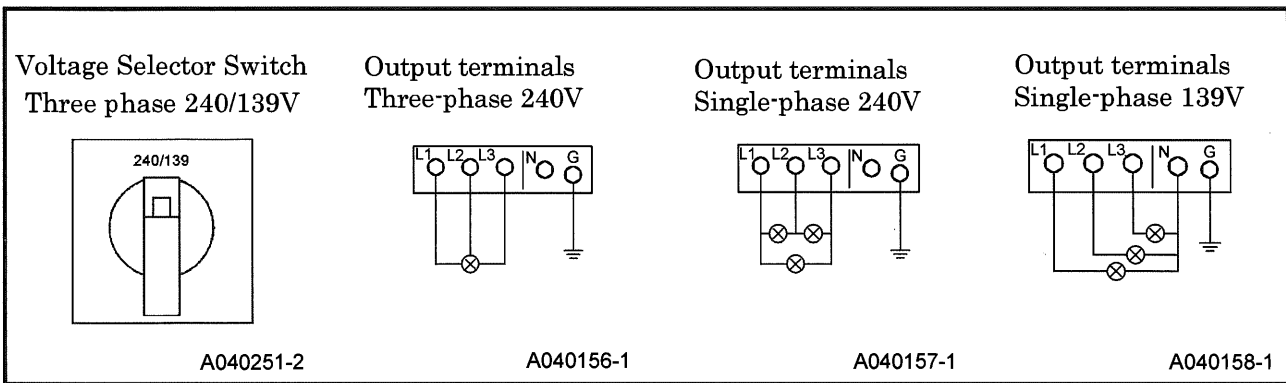
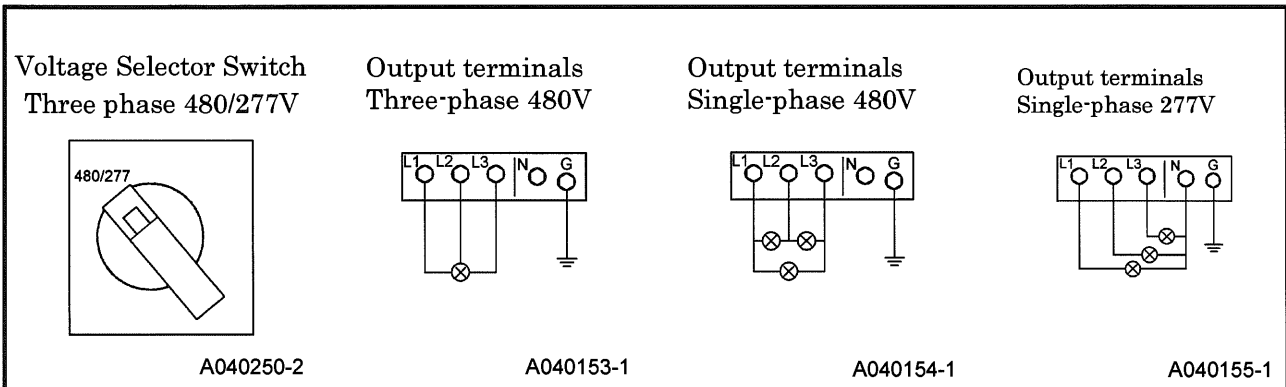

### CAUTION

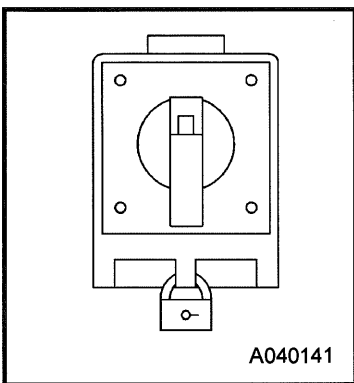

- During operation, do not operate the voltage selector switch. Voltage selection during operation may cause abnormal voltage on the load side to damage the load and may cause a fire.
- In addition, it could cause damage to generator and automatic voltage regulator (AVR).
- Be sure to shut off the generator before using the voltage selector switch.
- When voltage selection is completed, lock the voltage selector switch in position to prevent anyone from operating it.



# 3. Operation

## 3.2.2 Auxiliary AC Power

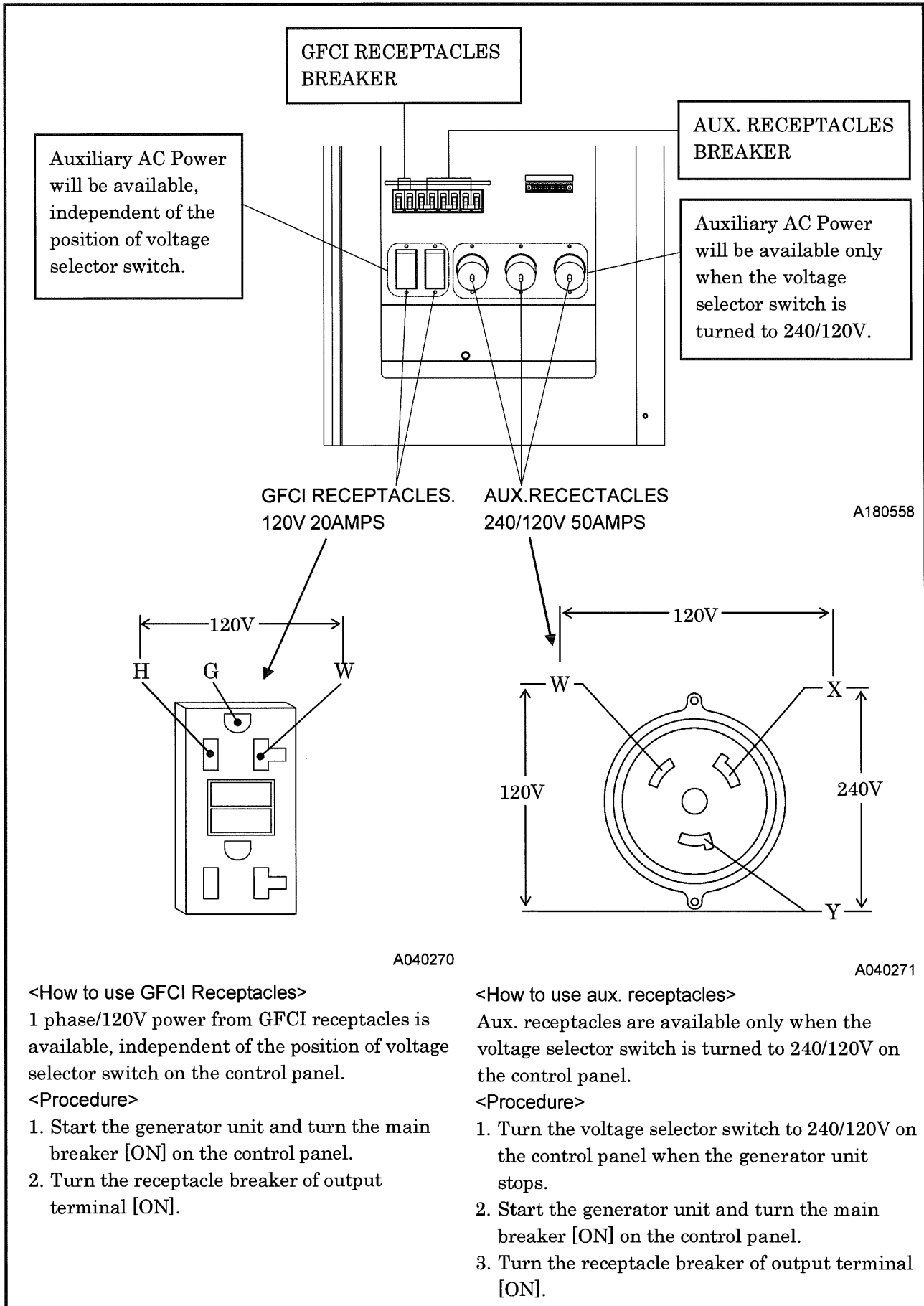

# 3. Operation

## 3.2.3 The Maximum Combined Simultaneous Power Consumption

The following chart shows the maximum power available from the 120V-20A GFCI receptacles during simultaneous consumption (main terminals and receptacles) for both single or three phase settings. Values shown in the left column give the maximum current available at the 120V-20A GFCI receptacles compared to the value of the simultaneous current consumption from the main terminals.

[Allowable load capacity of GFCI at single phase]

Single Phase (240/120V)	GFCI Receptacle
kW	A
28.3	0
27.1	5
25.9	10
24.7	15
23.5	20

[Allowable load capacity of GFCI at three phase]

Three Phase (240/480V)	GFCI Receptacle
kVA	A
36.0	0
31.8	5
27.7	10
23.5	15
19.4	20

### CAUTION

- When the main terminal, single-phase (240/120V) or three-phase (240/480V) is used together with the GFCI outlet (single-phase 120V), the above allowable load capacity of the GFCI outlet must not be exceeded.

# 3. Operation

## 3.3 Engine Oil • Coolant • Fuel

### 3.3.1 Engine Oil

Use engine oil recommended below. Be sure to use CJ-4 class or higher engine oil or superior class. (Using engine oil with poor quality may shorten the life of the engine).

Classification	API service classification CJ-4 class or higher
Viscosity	SAE10W-30 (as ex-factory)

#### IMPORTANT

- Viscosity of engine oil greatly affects starting, performance, and oil consumption of the engine, as well as wear of the moving parts. Choose appropriate oil based upon the table below according to the outside air temperature.

**Ambient temperature range and oil viscosity (SAE)**

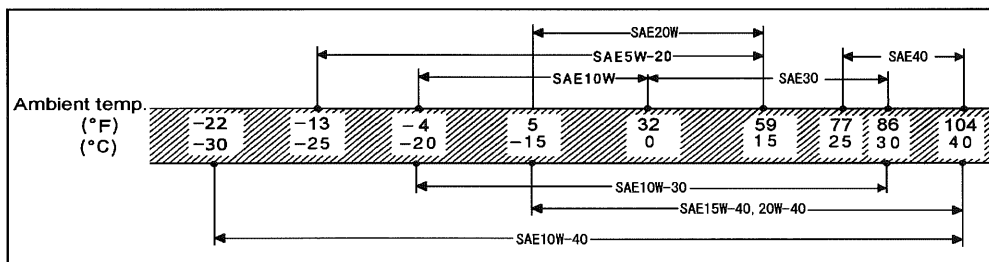

A180818E

- Do not mix oils. If two or more different brands of oil are mixed, its performance can be deteriorated.
- When the machine is operating under a light load (20% or less) for a prolonged period of time, check the viscosity of the engine oil and other fluids, and replace oil early using about half of the regular replacement time as a guide.
- Unit is delivered ex. factory, filled with engine oil recommended by engine manufacturer
- Dispose of oil in accordance with local laws and regulations.

# 3. Operation

## 3.3.2 Coolant

Coolant freezing could cause cracks of cylinder and radiator. Be sure to always use mixture of LLC (antifreeze) and soft water (like tap water) of good quality.

### IMPORTANT

- When water with dirt, sand, or dust, or hard water such as well water (ground water) is used, deposits can form inside the radiator or on the cylinder head and resulting in engine overheat from poor coolant flow.
- Adjust mixing ratio of coolant according to the temperature. (55% volume coolant is filled when the unit is shipped from factory.) Use coolant within the range of its mixing ratio between 60%. (If LLC (antifreeze) exceeds more than 60%, it may decrease its antifreezing effect.)

#### Mixing ratio of LLC (antifreeze) (reference)

Outside temperature (°F)	5	-4	-13	-22	-31	-40	-49
Outside temperature (°C)	-15	-20	-25	-30	-35	-40	-45
Mixing ratio (%)	30	35	40	45	50	55	60

- Dispose of LLC (Antifreeze) in accordance with local laws and regulations.

## 3.3.3 Fuel

### IMPORTANT

- Never use fuel with sulfur content greater than 0.0015% (15 ppm).
- Use only ultra-low sulfur fuel.
- Use such diesel fuel which conforms to either standard EN590 or ASTM D975.
- Dispose of fuel in accordance with local laws and regulations.

### CAUTION

- Diesel fuel is required to meet the following conditions.
  - Free from even minute dust particles
  - High optimum viscosity
  - High cetane number (more than 45)
  - High fluidity even at low temperature
  - Low carbon residue content

# 3. Operation

## 3.4 Before Starting the Unit

Be sure to check the unit before operation. When any abnormality is found, be sure to repair it before starting. Be sure to make daily check before operation. If the unit is operated without prior check and without noticing its abnormality, such operation could cause seizure of components or may even cause fire.

### 3.4.1 Check Engine Oil Level

The unit should be level before the checking oil level. When you check oil level after you have started operation, wait more than 10 minutes after stopping the engine before checking the oil level.

<Procedures>

1. Pull out the engine oil level gauge [A] and wipe it with a clean cloth.
2. Re-insert the engine oil level gauge [A] fully and pull it out again. If the gauge shows the oil level between LOW and FULL limits, it is normal.
3. When the oil level is below its LOW, add engine oil from engine oil filler port [B].
  - If the oil is found to be dirty or contaminated, change the oil. (See 5.4.1)
  - To prevent engine output reduction when oil level is too high, do not put more oil in than FULL.

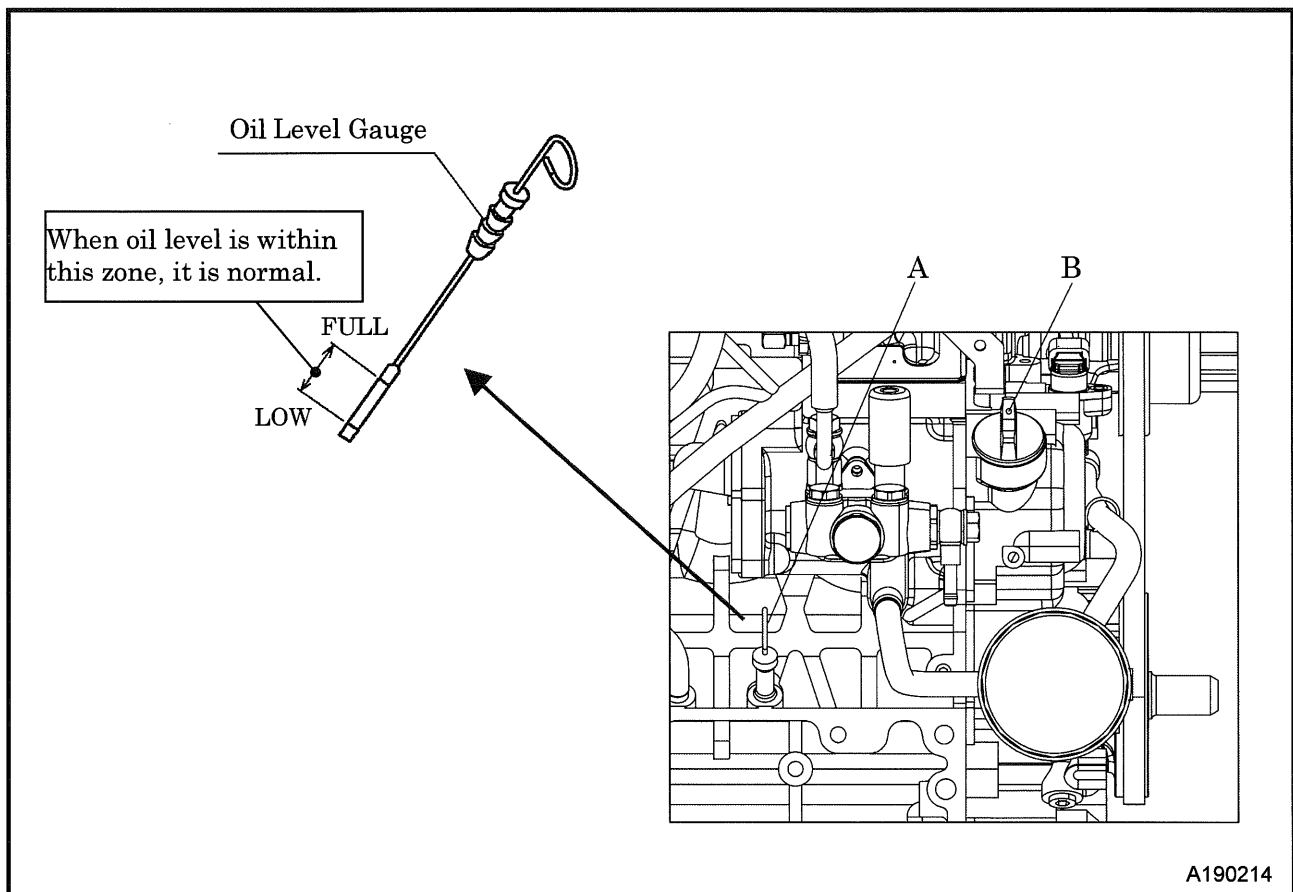

A190214

# 3. Operation

## 3.4.2 Check Coolant Level

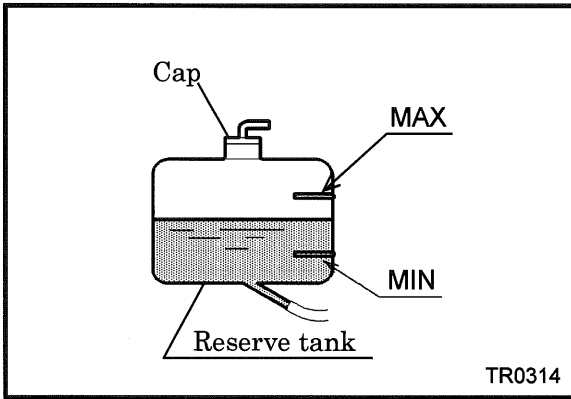

- Check the coolant level in the reserve tank and make sure it is above the MIN level.
- If coolant is below the MIN level, remove the cap and add coolant so that the coolant level is between the MIN and MAX levels. If too much coolant is added, it may spill out during machine operation.
- If there is no coolant in the reserve tank, remove the radiator cap and add coolant directly through the radiator fill port. (See 5.4.22)

### CAUTION

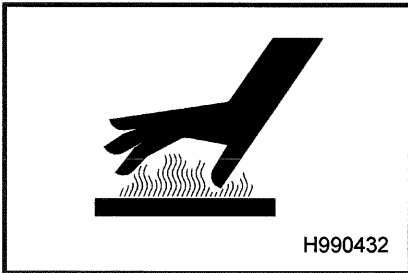

- When removing the radiator cap, lightly turn it and release the internal pressure without completely opening it once the first stage lock is released. After confirming that the internal pressure has been released, turn it off while pushing in until the second stage lock is released. If this procedure is neglected, its inner pressure can blow off the radiator cap, and steam jetting out of the radiator could cause scalding.

### IMPORTANT

- Do not operate the machine without sufficient coolant. Insufficient coolant can cause air bubbles to form and damage the radiator.

## 3.4.3 Clean Instruments In Control Panel

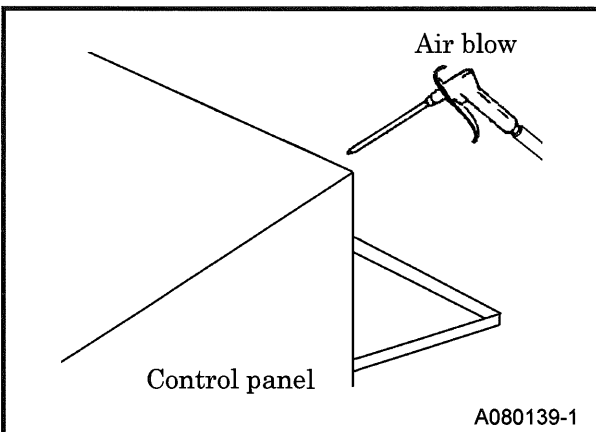

- Before starting operation, open control panel and check each breaker, terminal plate and each controller for any dust, sand and dirt accumulated.
- If the machine is operated with dust, sand, or dirt in the instrumentation, it could cause malfunction or damage. When necessary, clean the inside of the panel with compressed air. Wear protective eyewear when cleaning.

# 3. Operation

## 3.4.4 Check Fuel

Before starting operation, make sure to check the level of residual fuel so that fuel shortage during operation can be avoided.

If necessary, drain condensate accumulated at the bottom of the fuel tank.

- Refilling fuel tank should be done in an outdoor well-ventilated place.
- **Do not fill fuel up to the filler level.**

**When fuel tank is filled up to the filler level, the expansion volume of the tank is too small and could lead to problems with fuel flow and containment. Furthermore, fuel may spill from the fuel tank due to vibration caused during movement or transportation of the unit.**

※ When using an external fuel tank, note that the Fuel Level indication on the monitor will not reflect the actual fuel level.

### CAUTION



- Do not, under any circumstance, bring lit cigarettes and/or matches to the fuel.
- The fuel is extremely flammable and dangerous. Be careful of fire because the fuel is very likely to catch fire.
- Refuel only after stopping the engine, and never leave open fuel can near the machine. Do not spill. It could cause a fire. When it is spilled, wipe it up completely.
- Never use alcohol-base cleaning fluid.  
If it sticks to such parts made of plastic, it causes degradation of liquid surface visibility, and, in the worst case, can lead to cracking and result in fuel leaks.

## 3.4.5 Check Fuel Pre-Filter Drain

Drain water whenever it accumulates in the fuel pre-filter. An alarm will be displayed on the control panel when excess water builds up inside the pre-filter.

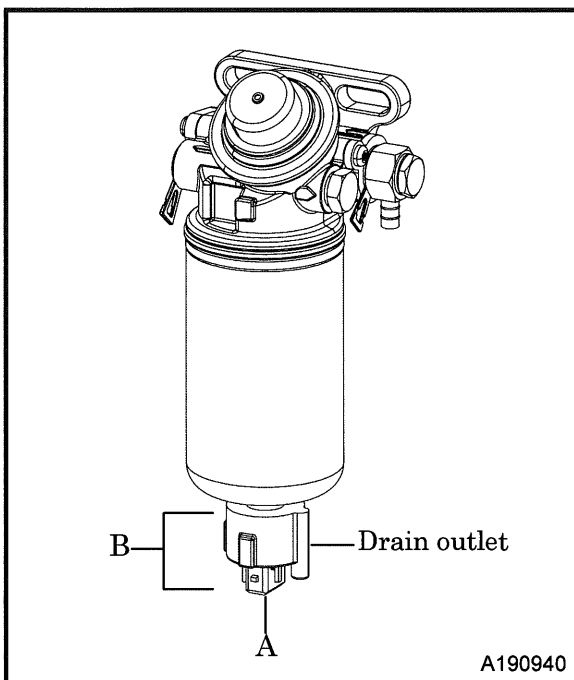

### <Procedure>

1. Remove the wiring connector connected to [A].
2. Connect a drain hose to the drain outlet.
3. Prepare a container and loosen the drain plug [B] to begin draining.
  - Fuel will be mixed in with the water, so take care not to spill.
4. When the water has been drained completely, retighten the drain plug [B] to stop.
5. Finally, reconnect the wiring connector removed from [A].
  - Drain the condensate into a container, and then dispose of condensate according to the designated regulations.

## 3. Operation

---

### 3.4.6 Check Interior

Periodically check the inside of the generator for dust and flammables

#### CAUTION

- Please wear personal protective equipment, such as a helmet, safety glasses, earplugs, safety shoes, gloves, and a mask as appropriate to the work environment.
- Periodically check the inside of the generator for dust and flammables. When any flammables such as chips of wood, dead leaves (dry leaves) and waste paper are left near heated exhaust muffler and heated exhaust pipe, all of them should be removed.
- Keep a fire extinguisher available by the machine in case of unexpected fire.
- It is advisable to have a list of phone numbers of doctors, ambulance and the fire department available in case of emergency.



# 3. Operation

## 3.4.7 Check Belt Tension

Adjust the alternator belt by the following procedure:

Unfasten the mounting bolts and nuts of the alternator to adjust the alternator belt.

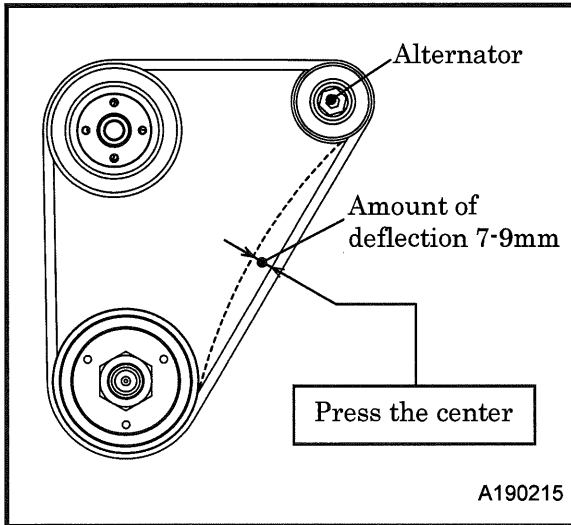

<Procedures>

1. Visually check there are no cracks or wear or other damage to the belt.
  2. Belt tension is adjusted by loosening the alternator mounting bolts and nuts. While pressing the center of the belt slightly, adjust belt tension by loosening fitting bolt so the amount of deflection is between 7 and 9mm (0.28-0.35in) [10kgf (22.1lbs)].
  3. If there is any oil or coolant on the belt, wipe it off completely during service.
- Refer to engine instruction manual for more details for belt adjustment.

### WARNING

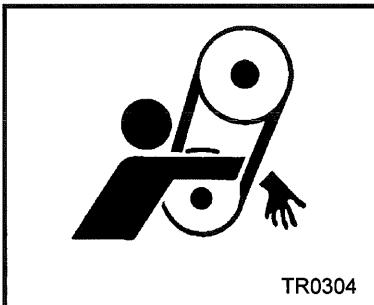

- Be sure to stop the engine whenever the tension of the belt is to be adjusted.
- Remove the negative (-) side cable from the battery.
- If the machine is running, it might catch the operator's hand into the belts, and this could cause a serious injury.
- Be sure to stop the engine whenever inspections and maintenance near the cooling fan.
- If the machine is running, it might catch the operator's hand into the fan, and this could cause a serious injury.

### IMPORTANT

- Over-tensioning of the belt leads to shaft breakage and reduced bearing life. If it is too loose, belt slippage may lead to premature breakage of the belt or damage to the machine due to overheating.

# 3. Operation

## 3.4.8 Check Thermo-Label of Alternator

Thermo-label on the stator irreversibly changes its color from white to brown by reaching or exceeding 212°F (100°C), that signalize overload during operation. Do not overload the generator.

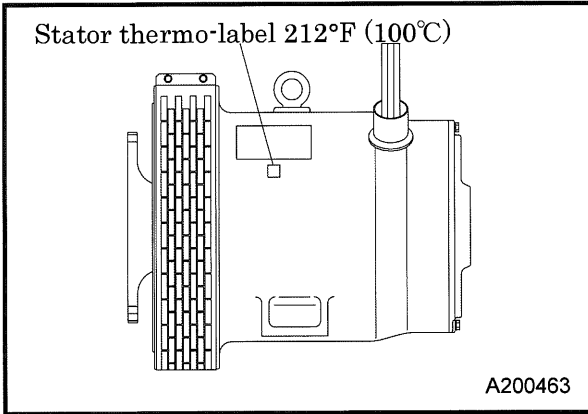

- Remove the trash and dust from the generator inside by compressed air blowing.
- Replace thermo-label if it has changed color.
- When replacing, contact your nearest dealer.

## 3.4.9 Check Oil Fence Drain

Oil fence drain port is located on the operation side (1 place).

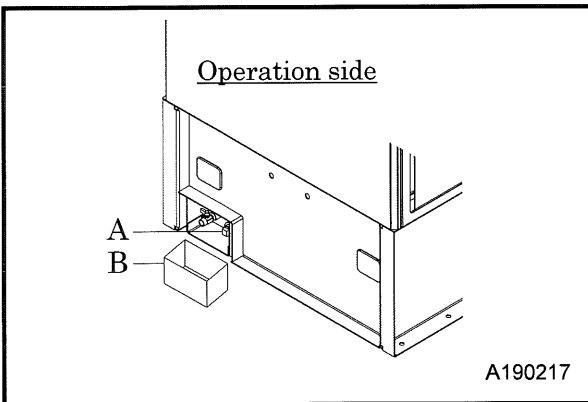

- Remove drain plug [A] from the oil fence drain to drain the condensate.
- Check that all condensate is drained, and then re-install the drain plug.
- Drain the condensate into a container [B], and then dispose of condensate according to the designated regulations.



- If the drain contains fuel, oil, or coolant, inspect each part for leaks.

## 3.4.10 Check Doors

Pull the handle forward to open the door. When closing the door, be sure that the door is securely latched.



- Keep the door closed and locked while running the machine.
- When opening the door unavoidably, be careful not to touch the moving s and hot parts. Scalding or serious injury could result.

# 3. Operation

## 3.5 Operating Procedure

Make sure that all enclosure doors are closed before starting.

### 3.5.1 Operating Procedure

To start, please follow the procedure below.

#### Manual Mode

<Procedures>

1. Set the circuit breaker [A] on the instrument panel to [OFF] position.
2. Set the selector switch [B] to [ON] position.
3. Push the manual mode button [C].
4. Push the start button [D] to run the engine.

(Preheating is started automatically in cold weather. After the glow lamp [E] is off, the engine starts.)

5. Once engine has started, let it warm up approximately 5 minutes at no-load condition.

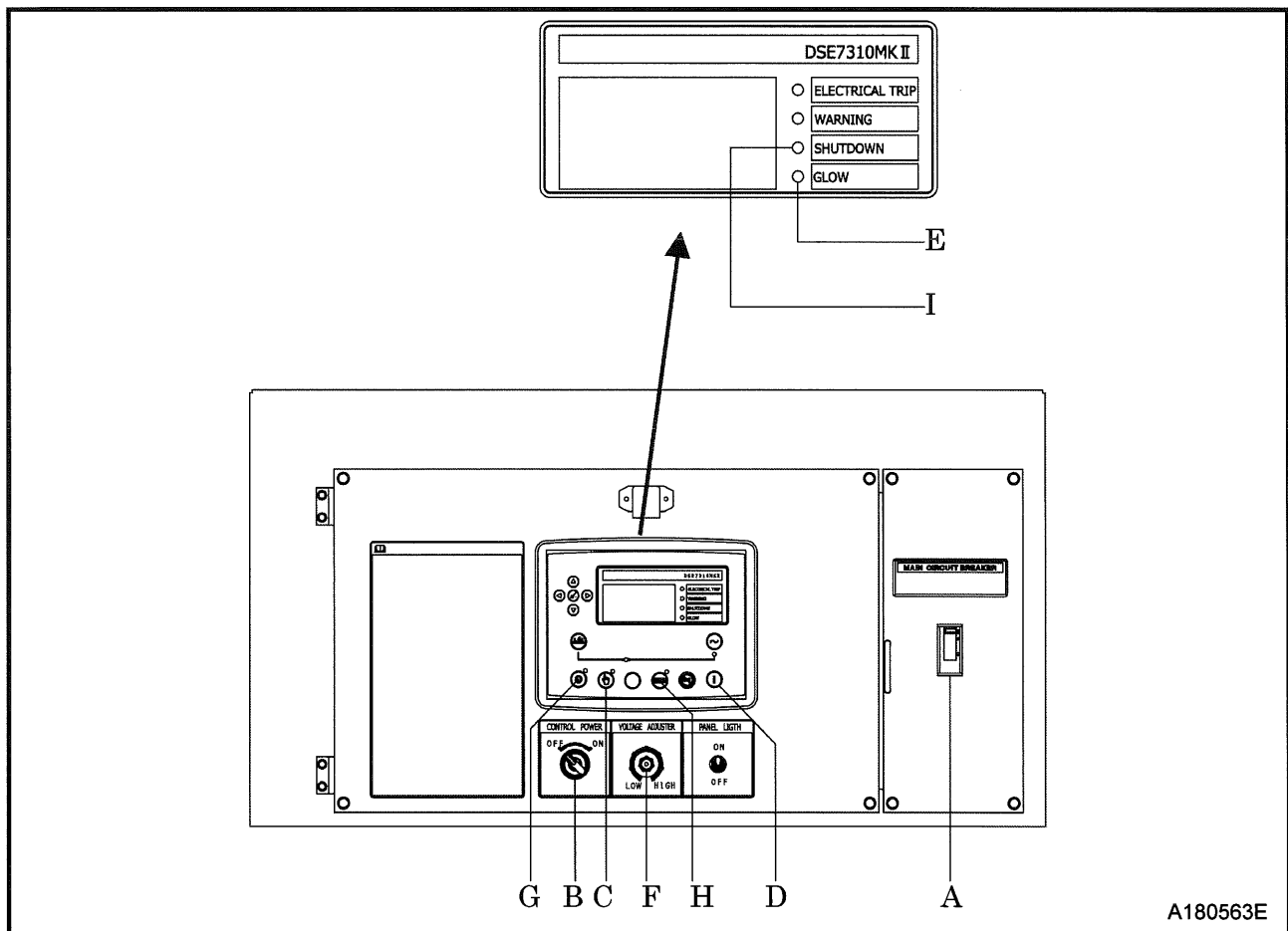

A180563E

#### WARNING

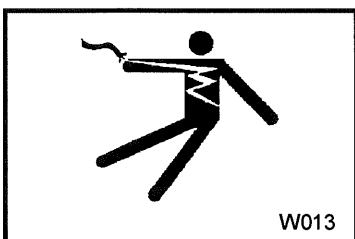

- Keep the output terminal cover shut and locked whenever the machine is running. Note that a voltage of several hundred volts is applied to the output terminal and control board. When opening the output terminal cover is unavoidable, be careful not to touch the output terminal. Electric shock or serious injury could result.

# 3. Operation

## Check frequency and voltage

<Procedure>

1. After warming up, display **Generator** monitor and press ▲▼ to show [Generator Frequency].  
Check that the frequency of the generator is at 60Hz after warm up. (See 3-2)

Generator Frequency	
60.0 Hz	

Monitor Screen

2. Press ▲▼ to show [Generator Voltage] and adjust to rated voltage with a voltage adjuster [F].

Generator Voltage	
L1-L2	480V
L2-L3	480V
L3-L1	480V

Monitor Screen



Voltage Adjuster

## Operation with Load

<Procedures>

1. Set the circuit breaker [A] to [ON] and supply power to the load.
  - During operation, check and confirm whether the generator functions properly. (See. 3.5.2)
  - ※ Before starting to supply power to the load, make sure that the voltage is in accordance with the load.

### IMPORTANT

- After the engine starts up, warm it up unloaded for approx. 5 minutes.
- Warming up after starting up is necessary for smooth operation of the engine. Do not operate the engine at full load immediately after it starts up. This will shorten the equipment life.
- During the warm-up operation, examine the different parts of the equipment for any looseness, leakage of water, oil, fuel, and other irregularities. Also, make sure that the alarm lamps are off.
- Be sure to operate the generator at the rated frequency, irrespective of the load capacity.  
If the machine is operated with a frequency lower than the rated frequency, it could cause the generator main machine or to be burned.

<Shutdown Procedure>

1. Stop the load.
  2. Set the circuit-breaker [A] to [OFF] position.
  3. After about 5 minutes cooling down operation, push the stop button [G] to stop the engine.
  4. Set the power control switch [B] to [OFF] position.
- ※ The engine controller is on for a few minutes after engine is stopped. Do not remove the battery cables, etc., during this period.

# 3. Operation

## Auto Mode

### 1. Cable connection method of remote control switch.

- Connect cables to the remote control terminal [A1-A2] on the terminal block [J], and install a remote operation switch between [A1-A2]. For this cable connection job, make sure to remove the battery cathode cable terminal.
- Connect a charger to the charging terminal [P-N] on the terminal block [J].

#### <Procedures>

1. Adjust rated voltage in manual mode and stop the engine.
2. Push the auto mode button [H].
3. Set the circuit-breaker [A] to [ON] position.
4. Set the remote operation switch between the [A1-A2] terminals to ON to start the engine.  
(In cold conditions, pre-heating starts automatically. After glow lamp [E] is switched off, the engine starts.)
5. To stop the engine, set the remote operation switch to between [A1-A2] to OFF.

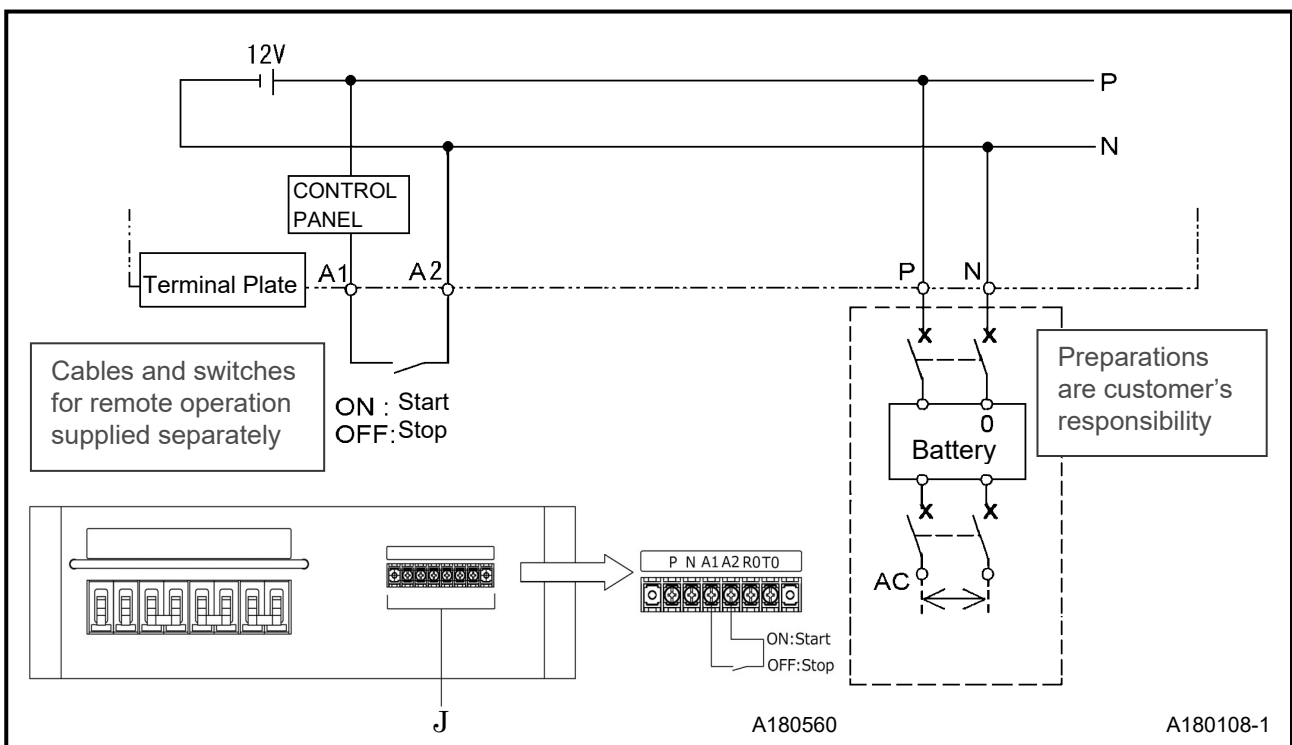

## CAUTION

### Inspection and maintenance prohibited during auto mode



- While auto mode is active, refrain from touching inside of the machine as it may start without warning.
- Before starting inspection and maintenance job, make sure to hang the tag "Under inspection and maintenance".
- Remove the battery cathode cable terminal.

## IMPORTANT

### Install the battery charger

- Battery will be discharged while auto mode is stopped. Make sure to charge battery, operating the battery charger.

# 3. Operation

## 2. Function

- When the start signal activates in stand-by mode, it starts the unit. (This includes preheating.)  
When the stop signal activates, the unit will continue to operate for 10 seconds to cool down, then the unit stops and is placed again in stand-by mode.

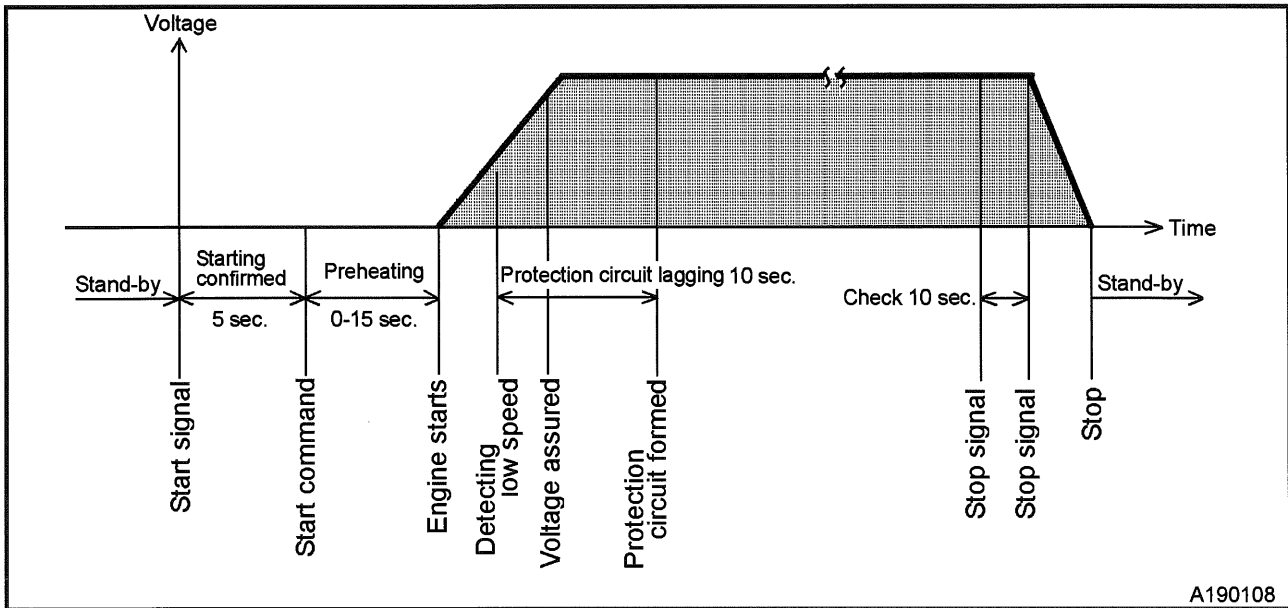

## 3. Starting Action

- If the engine will not start after cranking for 10 seconds, stop it for 8 seconds before trying again. If the engine will not start even after cranking is repeated three times, the SHUTDOWN lamp [I] will illuminate due to Fail to Start error.
- If the engine will not start and the SHUTDOWN lamp is illuminated, troubleshoot the cause of engine failure before proceeding.

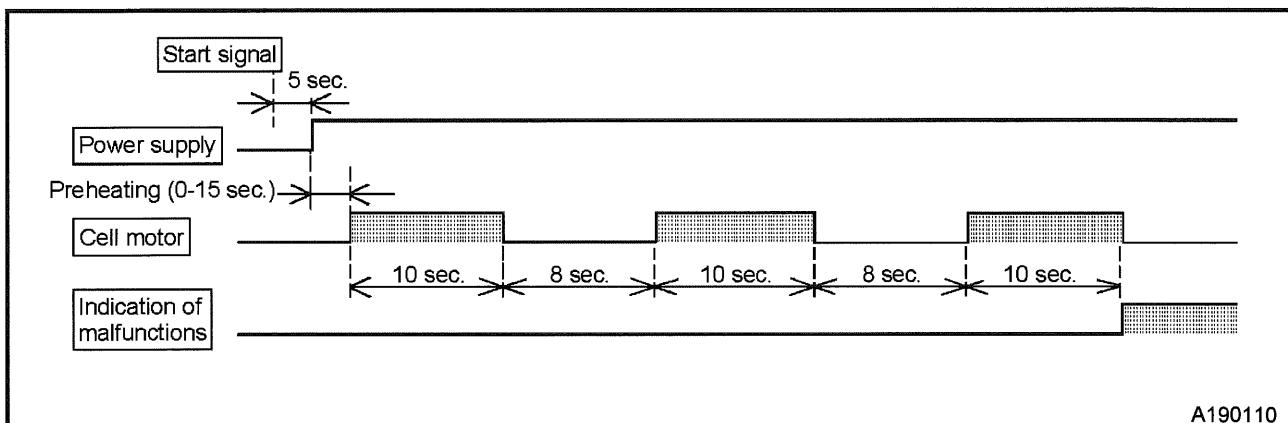

**IMPORTANT** Perform periodical inspection and maintenance of the generator

- To check performance, run the unit for 5 to 10 minutes once in a week.

# 3. Operation

## 3.5.2 Meters and indicator lights during operation

During normal operation, each indication of instruments is shown in the table below. Refer to the table for daily checks.

Note: The values marked \* vary with location of the voltage selector switch.

		Voltage (V)	Frequency (Hz)	Ammeter (A)	Monitor Lamp			
					ELECTRICAL TRIP	WARNING	SHUTDOWN	GLOW
Before Start	CONTROL POWER switch (ON)	0	0	0	● OFF	● OFF	● OFF	● OFF
		* 240 480	60	Less than rated current	● OFF			

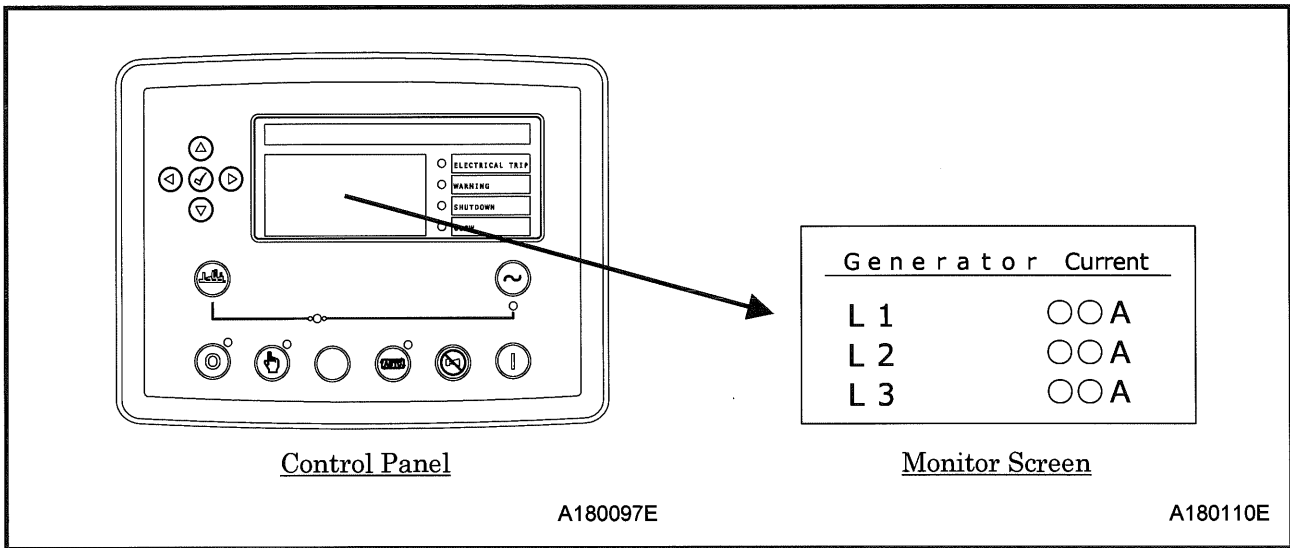

- Be sure to frequently check meters and indicators for proper operation, or any machine water, oil, fuel leaks, etc.
- The above table gives standard values. They may vary slightly depending on operating conditions and other factors.
- In single-phase load operation, check the current of L1, L2, and L3 phase with displaying Generator page. Each current should be balanced if unbalanced. Change load connections so the current of L1, L2, and L3 is equally balanced. Make sure that the current of each phase does not exceed the rated one.

※ Keeping a record of machine operation and service checks in the Operation Log will help with discovering any underlying issues or problems with the machine before they become severe.

## 3. Operation

### CAUTION



- Do not under any circumstance, open the portions below during operation.
- Coolant drain valve
- Engine oil drain valve

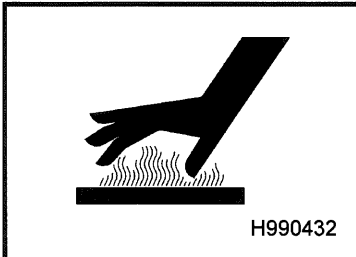

- Never work nearby hot portions of the machine while it is running.
- Do not touch hot portions of the machine while inspecting the machine when running.
- Parts such as the engine, exhaust manifold, exhaust pipe, muffler and radiator are especially hot. Never touch those parts, because it could cause scalding.
- Coolant water and engine oil are also very hot and dangerous to touch. Avoid checking or refilling them while the machine is running.

- When the breaker functions often during operation, reduce the load.
- When using 1-phase load, check the current of each phase and try to keep the load of each phase constantly average.
- If you continue to operate the generator while ignoring or neglecting these cautions, it could cause overheating and result in fire. Furthermore, should operation continue at a lower level than the standard rated frequency, it could burn the generator and any motors of the attached load.

### 3.5.3 Panel light

- The panel is equipped with an LED light. Turn the panel light switch [ON] to use.
- When illumination is not necessary, turn the light [OFF]. If the machine is always operated with the lamp switched [ON], the lamp life can be reduced.

### 3.5.4 Operating procedures when engine fails to start up on first attempt

If the engine repeatedly fails to start, the following causes are suspected. Check the following:

- No fuel
- Clogging of the fuel filter
- Discharge of battery (Low cranking speed)



# 3. Operation

## 3.5.5 Fuel line air bleeding device

If the machine runs out of fuel, bleed the air, according to the following procedures.

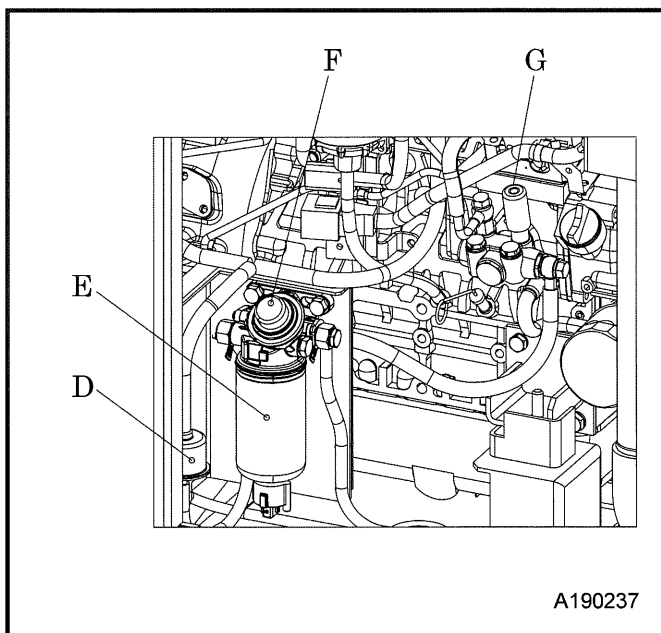
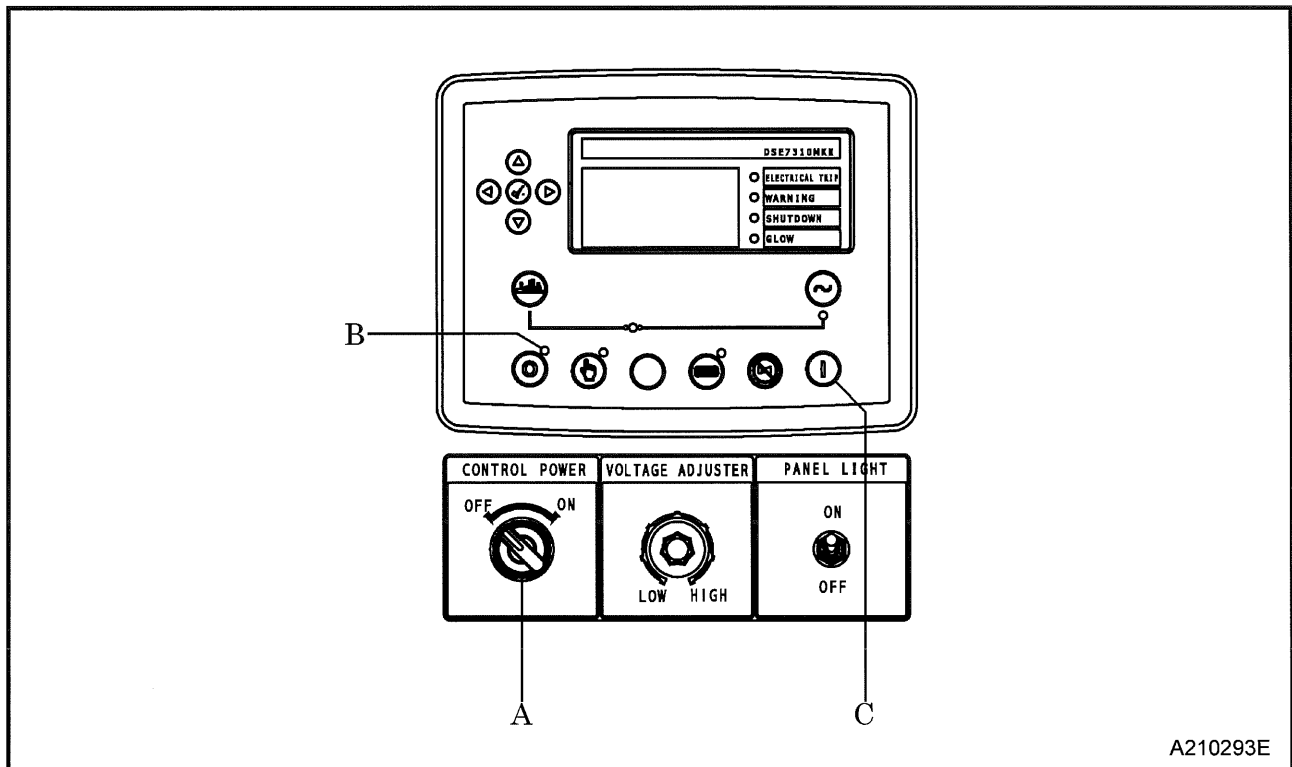

### <Procedure>

1. Refill the fuel.
2. Set the control power switch [A] to [ON] position.
3. When the stop mode indicator lamp [B] is lit, press the start button [C] to turn on the electromagnetic pump [D].
4. Pump the fuel pre-filter element [E] priming pump [F] and then pump the engine supply pump [G] until the pump the air has been bled out. The pump will feel heavy and resist pushing when the system is clear of air.

## 3.5.6 How to check engine information

By pressing the start button [C] when the stop mode indicator lamp [B] is lit, the key can be turned ON without starting the engine, and the water temperature, ECU current DTCs, etc. can be checked. After 2 minutes, the system will automatically return to the key OFF state.

# 3. Operation

## 3.6 Emergency Stop

### 3.6.1 Emergency stopping procedures

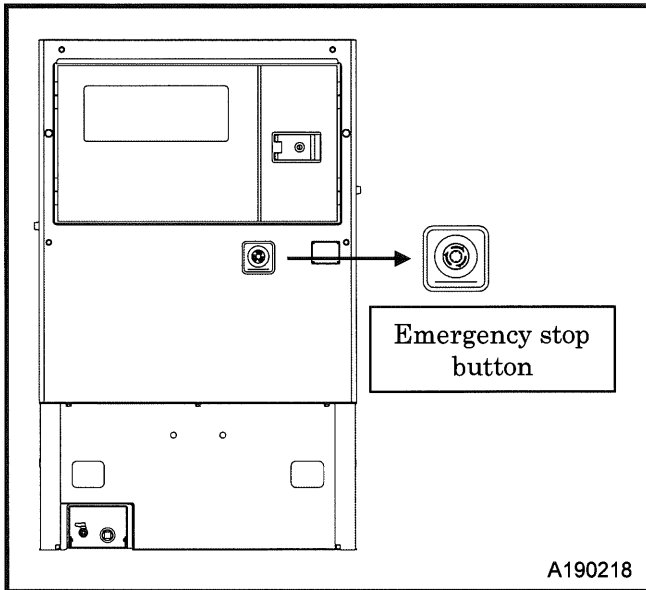

- If it is necessary to stop the generator for emergency, press the Emergency Stop button located under the control panel. When shutting down with the emergency stop button, the machine will stop immediately.

### 3.6.2 Cancellation of emergency stop button

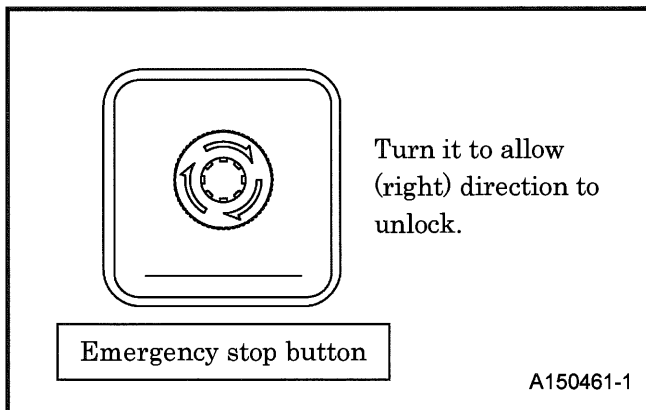

- After emergency stopping, be sure to carry out an investigation of the problem which caused you to use the emergency stop and take appropriate countermeasures. Release emergency stop button only after resolving the problem that required an emergency stop. To reset the button, turn the button head in the direction of the arrow.

※ If it is not reset, the machine cannot restart.

# 4. Failure and Troubleshooting

## 4.1 Protection device

To prevent issues during operation, this machine is equipped with various protection devices.

### 4.1.1 List of protective devices, warning lamps, and monitor alarms

This machine is equipped with protective devices, and indicates the type of issue with lamps and messages on the monitor display as shown in the table below. Shown below are the typical items. When the Warning lamp is activated or any other monitor alarm is displayed due to other engine trouble, contact your nearest dealer.

Item	Control Panel					Function
	Monitor Lamp			Screen		
	Electrical Trip	Warning	Shutdown	Alarms	ECU Current DTCs	
Low Engine Oil Pressure	☀️ ON	-	☀️ ON	ECU Red	ENG Oil Press. Low	Warning: lower than 7PSI (49kPa)
High Coolant Temp	☀️ ON	-	☀️ ON	ECU Red	Water Temp High	Shutdown: above 230°F (110°C)
Over speed	☀️ ON	-	☀️ ON	ECU Red	Engine Speed High	Shutdown: above 2070RPM (69Hz)
Clogging Air Filter	-	☀️ ON	-	Air Filter	-	When it is clogged or necessary to clean.
Oil Fence	-	☀️ ON	-	Containment Level	-	When condensate (fuel, engine oil and coolant) is accumulated more than 10.5gal (40 liters)
Low Fuel Level*	-	☀️ ON	-	Low Fuel	-	Warning: less than 5% of capacity
Over Current/ Short Circuit	☀️ ON	-	☀️ ON	Over Current	-	When it occurs
High Voltage	☀️ ON	-	☀️ ON	Over Voltage	-	Shutdown: above 108%
Other Engine Trouble	**	**	**	-	**	**

\*Not functional when using an auxiliary/external fuel tank.

\*\*Please contact your nearest dealer.

When ECU Red or ECU Amber is displayed, press button once to change screen to ECU current DTCs and check screen.

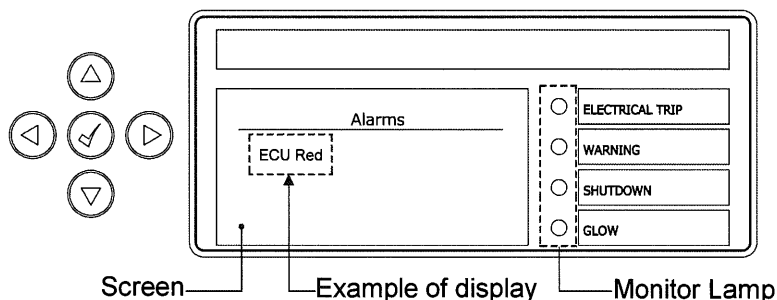

A180100E

### CAUTION

- If the protective device operates and the engine stops or the circuit breaker trips, refer to the cause of the failure and the countermeasure item, eliminate the cause and restart operation.

# 4. Failure and Troubleshooting

## 4.1.2 Circuit Breaker

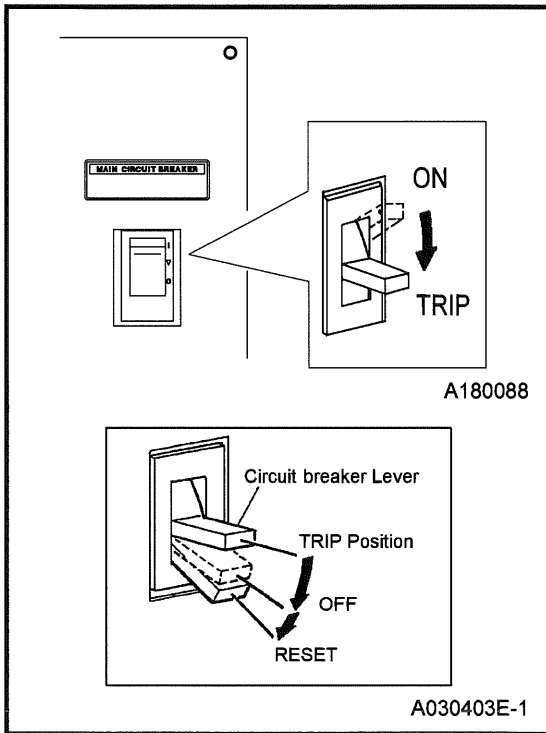

- In case of an overload or short-circuited wire connection, the circuit-breaker trips.
- When the breaker is tripped, stop the machine immediately and reset the circuit breaker after resolving the cause of the trouble.

### <How to reset>

- In order to reset the lever of circuit breaker, press the lever downward firmly until the lever “clicks” into place.

## 4.1.3 Circuit protector (CP) for AVR protection

AVR is equipped with a circuit-protector (CP) for protection against over current. It will activate under the following conditions:

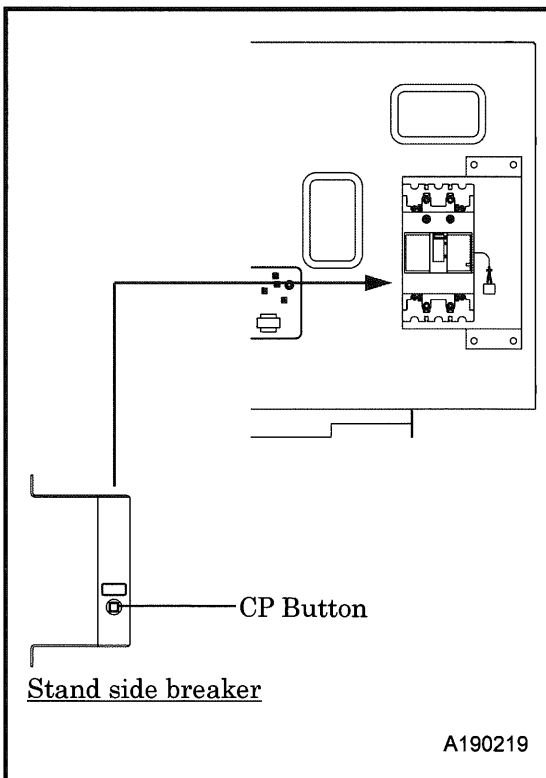

- The machine is overloaded while engine speed is still low.
- The output voltage of machine is increased higher than the specified voltage.

### <Symptom>

- When the CP operates, following symptoms will occur.
  - (1) The voltage will not reach rated voltage.
  - (2) The voltage is usable, but voltage fluctuation is wide and voltage restoration is slow when loaded.

### <How to reset>

- Reset it by pressing CP (AVR) button provided at the side of the breaker plate in the control panel.

# 4. Failure and Troubleshooting

## 4.2 Troubleshooting

Should any trouble occur during operation, do not leave it. Investigate the cause and take appropriate measures. Read the manual carefully and fully understand what to do in case of trouble.

- The better you understand the construction and function of the machine, the faster you can find a problem and solution.
- This chapter describes the state, cause and countermeasures of important troubles in detail:

Symptom	Cause	Counter measures
Starter does not rotate. Low starter revolution speed even when starting.	(1) Battery malfunction (2) Charging malfunction (3) Alternator malfunction (4) Starter malfunction	Check Battery → Charge/Change Change Change
Starter rotates normally but engine does not start up.	(1) No diesel fuel oil (2) Air mixing in fuel piping (3) Fuel filter clogging  (4) Nozzle clogging (5) Malfunction of controller	Replenish fuel Bleed air Disassemble/Clean and Change Disassemble and clean Check fuse Check connector Check controller
※ “Engine Oil Pressure Low” is displayed on the monitor screen.	(1) Engine oil shortage (2) Engine oil filter clogging (3) Looseness, disconnection of wiring or connectors (4) Oil pressure switch malfunction	Replenish engine oil Change Check/tightening Change
※ “Water Temperature High” is displayed the monitor screen.	(1) Shortage of coolant (2) Slip of belt (3) Radiator clogging (4) Faulty thermostat (5) Looseness, disconnection of wiring or connectors (6) Faulty coolant temperature switch	Replenish coolant Adjust tension Clean Change Check/tightening Change
※ “Air Filter” is displayed on the monitor screen.	(1) Clogged air filter element	Clean or replace filter element
※ “Containment Level” is displayed on the monitor screen.	(1) Condensate accumulated in the oil fence. (2) Oil fence level sensor is not functioning.	Drain Check/Change

※ Refer to section 4.1.1 for monitor lamp and display.

## 4. Failure and Troubleshooting

Symptom	Cause	Counter measures
Circuit breaker trips.	(1) Overloaded (2) Short-circuit occurred at the load side.	Reduce the load Get rid of cause of short-circuiting.
Even when operated at a rated speed, no voltage or too low voltage generated.	(1) Poor tightening of each terminal (2) Broken or short-circuited circuit to exciter field winding (3) Faulty exciter (4) Function circuit protector (CP) for AVR protection (5) Faulty AVR (6) Broken or short-circuited winding of generator main machine (7) Faulty silicon rectifier (mounted on generator main machine rotor) (8) Faulty voltmeter	Check/tightening Repair  Repair Reset  Change Repair  Change  Change
Too high voltage generated when set at the rated frequency (50Hz/60Hz), Voltage will not drop even when the voltage regulator controlling knob is turned.	(1) Loosened or disconnected wiring, or connector to AVR (2) Broken wire or poor contact of AVR variable resistor (3) Faulty AVR	Check/tightening  Repair or change  Change
Unstable voltage generation	(1) Poor tightening of each terminal (2) Function circuit protector (CP) for AVR protection (3) Faulty AVR	Check/tightening Reset  Change

- Contact your nearest dealer if you find it difficult to repair by yourselves.
- Please see engine operation manual for more details of engine trouble.

# 5. Periodic Inspection

## 5.1 Important Items at Periodic Inspection and Maintenance

The following table shows the inspection and maintenance intervals under normal operation conditions. When used or operated under hard environmental conditions, it is impossible to warrant the machine even if the above conditions are performed according to the intervals listed in the above table.

- Be sure to use appropriate tools for inspection and maintenance work. Inappropriate tools could cause unexpected injury.
- Please wear personal protective equipment such as a helmet, safety glasses, earplugs, safety shoes, gloves, and a mask as appropriate to the work environment
- Do not touch hot portions of the machine while inspecting the machine when running. Parts such as the engine, exhaust manifold, exhaust pipe, exhaust muffler, radiator, inter cooler, generator, and pipe are especially hot, so never touch those parts, because it could cause scalding.



**WARNING**

Hang a "Under Maintenance" tag

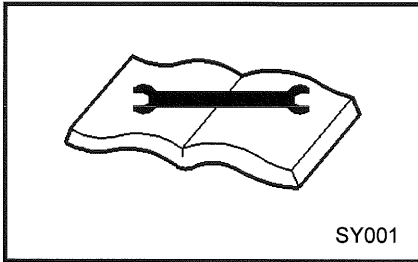

- Before starting inspection, set the machine's circuit breaker to OFF, and then attach the "Under Inspection" label to an easy-to-see location.
- Remove the negative (-) side cable from the battery. If the above procedure is neglected, and another person starts operating the machine during check or maintenance, it could cause serious injury.

**IMPORTANT**

Instructions and unspecified work prohibited

- Be sure to use recommended fuel, oil, grease, or antifreeze.
- Do not disassemble or adjust engine, generator or part(s) for which inspection or maintenance is not referred to in this manual.
- Use genuine parts for replacement.
- Any breakdown, caused by using unapproved parts or by wrong handling, will be out of the scope of "WARRANTY".
- Do not pour water or steam on electrical components.
- Place a container or a pan underneath the oil port to receive waste liquid so that such liquid cannot be spilled out on the floor or inside the machine.
- Be sure that no waste liquid is disposed of on the ground. Such waste on the ground, river or lake will cause serious environmental contamination. Be sure to follow the local regulations. If harmful material such as oil, antifreeze solution or filters are disposed of incorrectly, the responsible person should be punished by the authority.
- Observe local regulations when disposing of such toxic materials as oil, fuel, coolant (Antifreeze), filters, and battery etc.

# 5. Periodic Inspection

## 5.2 Maintenance Schedule

Such items marked ○ shall be carried out by customers. For the following items or clauses marked ●, contact your nearest dealer because they require expert technical knowledge on them.

The following table shows the intervals of inspection and maintenance under normal operation conditions. Inspection and maintenance should be done at either of the hour or the period mentioned in the remarks column, whichever comes earlier.

(This table is a guide only, it is not a guaranteed time. Please change maintenance interval according to usage load environmental condition.)

(Unit : Hour)

Maintenance		Daily	50 First time	250	400	500	1,000	Ref.	Remarks
Generator	Clean instruments in control panel	○						3-10	Clean as required.
	Check thermo-label of alternator	○						3-14	
	Check control panel	○						3-19	
	Check GFCI receptacles			○				5-8	Every 1 month
	Check insulation resistance			○				5-9	Every 2 month
	Check thermo-label on the generator			○				5-11	Every 2 month
Engine related	Check engine oil level	○						3-9	
	Check coolant level	○						3-10	
	Check fuel	○						3-11	
	Check belt tension	○						3-13	In the case of NG, it exchanges.
	Change engine oil		○		○			5-4	
	Change engine oil filter element		○		○			5-5	
	Check battery electrolyte			○				5-5	
	Check and clean air filter elements			○				5-7	
	Check accumulations in exhaust system			○				5-8	
	Drain fuel tank			○				5-11	
	Check specific gravity of battery electrolyte.					○		5-5	
	Change fuel filter element				○			5-11	
	Change fuel pre-filter element					○		5-12	
	Clean outside of radiator and intercooler					○		5-12	Clean as required.
	Drain intercooler					○		5-12	
	Check exhaust flexible pipe					○		5-13	Every 4 month
	Change air filter elements						○	5-14	
	Change coolant (LLC)						○ (Every 2 years)	5-16	
Clean fuel tank						●			
Others	Check interior	○						3-12	
	Check oil fence drain	○						3-14	
	Check terminal and wirings					○		5-13	Every 4 month
	Check engine/generator mount						○	5-15	Every 1 year
	Check each rubber hose						○	5-15	Every 1 year
	Clean the oil fence and check for rust						●	5-15	Every 1 year

The above intervals of inspection and maintenance are respectively based on the operation time of 125 hours of used per month and of 1,500 hours of use per year.



# 5. Periodic Inspection

(Unit : Hour)

Maintenance		800	1,500	3,000	Ref.	Remarks
Engine body	Check engine valve clearance	●				
	Check fuel injector nozzle		●			
	Check EGR Cooler		●			
	Replace oil separator element		○		5-14	
	Check PCV valve		●			
	Inspect turbocharger			●		
	Check EGR system			●		

## 5.3 Periodic Replacement Parts

Part number changes upon modification. For replacement of parts, make sure whether the part number is correct or applicable.

Description	Part Number	Q'ty
Air Filter Element	32143 11700	1
Engine Oil Filter Element	37438 07800 KUBOTA HH164-32430	1
Fuel Pre-filter Element	43543 03100 KUBOTA 1E786-43060	1
Fuel Filter Element	43543 03000 KUBOTA HH1JO-43172	1
Oil Separator Element (w/O-ring)	KUBOTA 1J770-05810	1
Belt	KUBOTA 1G382-97010	1

# 5. Periodic Inspection

## 5.4 Maintenance Items

### 5.4.1 Change Engine Oil (Change the engine oil filter at the same time)

**50 hour (first time only) and every 400 hour maintenance items**

When checking, replenishing, and draining the engine oil, be sure to wait more than 10 minutes after engine stops to allow it to cool down.

<Procedures>

1. Remove the engine oil filler port cap [A], and remove the drain plug [B] fixed outside, and then open the drain valve [C] fixed inside to drain oil.
  2. After draining completed, close the drain valve [C] and install the drain plug [B] and supply engine oil. [Oil supply: about 9.7L]
  3. After finishing the oil supply, tighten the cap of engine oil filler port firmly.
  4. Make sure to check engine oil level with the engine oil level gauge before start the unit.
- Drain oil into an appropriate container [D] and dispose of it accordingly to local rules and regulations.

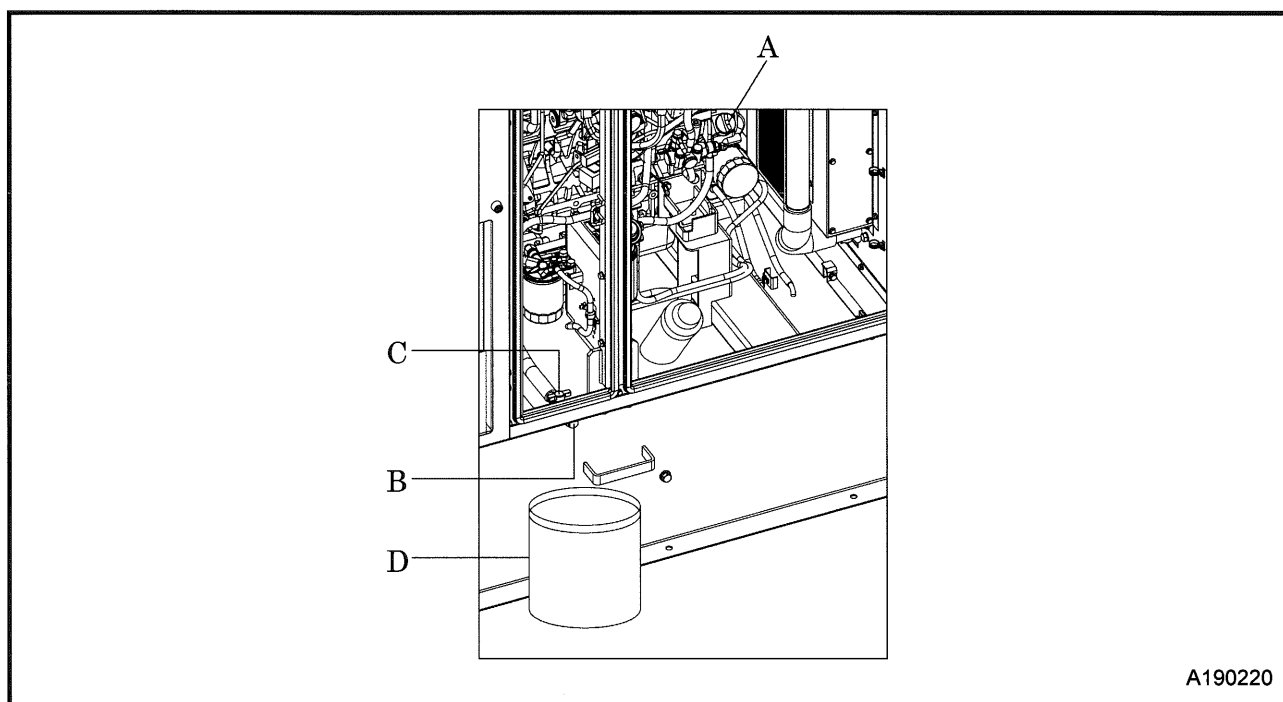

#### Caution in filling or draining engine oil

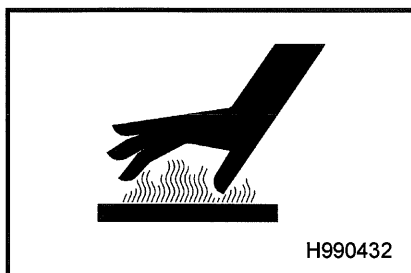

- Engine oil is very hot and highly pressurized during or just after the operation. Hot oil could blow out and can cause injury
- Never supply more engine oil than the proper level. Too much oil could cause white smoke out of the exhaust, and it can cause damage and accident to engine.

# 5. Periodic Inspection

## 5.4.2 Change Engine Oil Filter Element

50 hour (first time only) and every 400 hour maintenance items

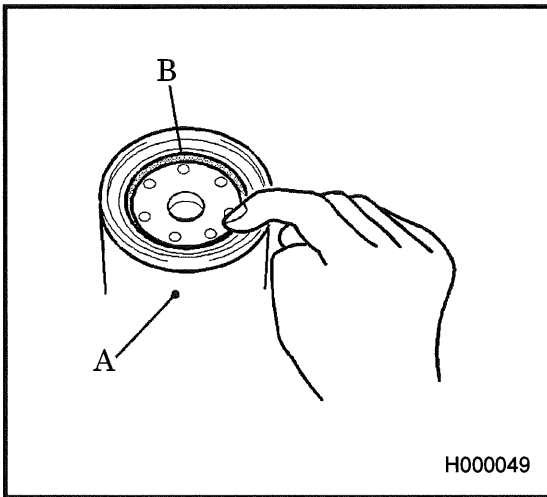

<Procedures>

1. Take out the oil filter element [A] using a filter wrench.
  2. After thinly applying oil on the new gasket [B], screw it in. After the gasket touches the sealing face, tighten another 2/3 turn with a filter wrench.
  3. After installing the oil filter element [A], check it for any leak during operation. (For part number, See 5.3)
- Refer to the engine instruction manual for more details.

## 5.4.3 Check Battery

Battery electrolyte : every 250 hours

Specific gravity of battery electrolyte : every 500 hours

If there to be a problem in starting an engine due to a flat battery, carry out the checks by following the procedures below:

### ● Ordinary type battery:

Measure specific gravity of battery electrolyte, and if it shows below 1.24, recharge the battery immediately. (See 5.4.4)

### ● Enclosed type battery:

Check the indicator on top surface of the battery.

If the indicator shows that charge is needed, recharge the battery immediately.

If specific gravity of battery electrolyte does not rise despite replenishing distilled water or charging battery, replace battery with a new one quickly.

# 5. Periodic Inspection

## 5.4.4 Maintenance of Battery

Battery may generate hydrogen gas and may explode. Therefore, recharging should be done at a well-ventilated place.

- Do not check the battery by short-circuiting the positive and negative terminals with a metallic piece.
- Never operate the machine nor charge the batteries with low battery liquid. Continuing operation at this lower level will cause deterioration of some parts, reduction of battery life, and also it may cause explosions. Add distilled water so that the liquid level is between the "UPPER LEVEL" and "LOWER LEVEL" if the level is too low.
- Wear protective gloves and safety glasses when handling a battery.
  - If battery electrolytes contact your clothes or skin, wash it away with a large amount of water immediately.
  - If the battery electrolytes get into your eyes, flush them immediately with plenty of water and see a doctor at once. Severe damage to eyes and vision may result.



**WARNING**

### Handling Battery



D004

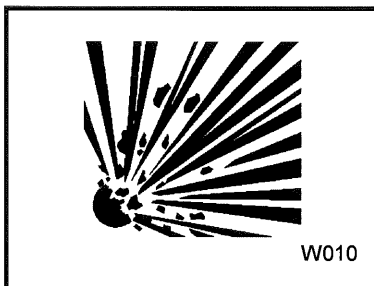

W010

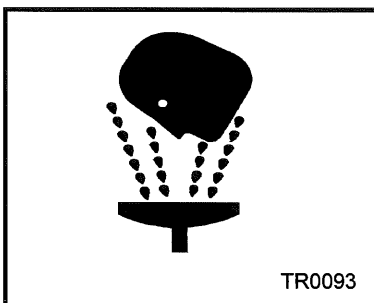

TR0093

- Keep flames away from battery.
- Do not spark near the battery nor light a match, nor bring lit cigarette and match close to the battery.
- Do not charge a frozen battery as it may explode. If the battery is frozen, warm it up until the battery temperature becomes 61°F to 86°F (16°C to 30°C).
- Battery electrolyte is diluted sulfuric acid. In case of mishandling, it could cause skin burning.
- Dispose of battery, observing local regulations.

### [Charge battery]

- Use the battery charger after you confirm whether it is in good operating condition and ready for use.
- Disconnect the cable between battery and the machine, and charge the battery with a 12V battery charger.
- Be sure not to connect (+) and (-) terminals backwards.

# 5. Periodic Inspection

[How to use booster cable]

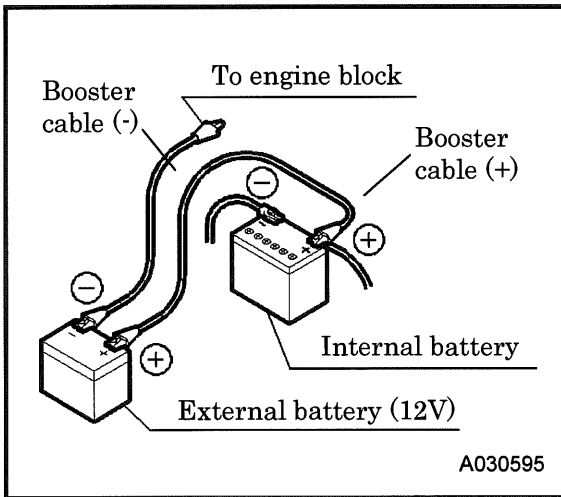

<Procedure>

1. Stop the engine.
2. Connect one end of the (+) booster cable to the (+) terminal of the machine battery.
3. Connect the other end of the (+) booster cable to the (+) terminal of the external battery.
4. Connect one end of the (-) booster cable to the (-) terminal of the external battery.
5. Connect the other end of the (-) booster cable to the engine block of the machine.
6. Start up the engine.
7. Disconnect the booster cable by following the procedure back in the reverse order.

## CAUTION

- When a booster cable has to be used or when cables are connected again after a battery is replaced, be careful not to connect (+) and (-) terminals backwards. A backwards connection will cause sparking and damage to each component.

### 5.4.5 Check and Clean Air Filter Elements

Every 250 hours

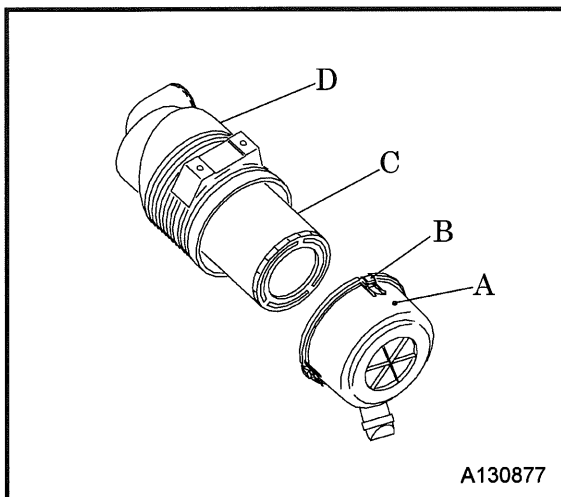

Clean the air filter displayed on the monitor screen.

<Procedures>

1. After removing the cap [A] by loosening its cap fixing latch [B], clean its interior properly.
  2. Remove the outer element [C], and clean it.
  3. When installing the cap after finishing the cleaning job, push the element into the case [D] firmly by hand, and then make sure that the cap fixing latches attach securely to the case. Lastly, tighten the latches.
- If the element is found heavily dusty, replace it with a new one. (For part number, See 5.3)

## IMPORTANT

- When an element that is clogged or has holes or cracks is used, dust or foreign material will get in the engine. This causes accelerated wear in moving parts within the engine. Be sure to perform daily checks and appropriate cleaning so that the life of the engine will not be shortened.

# 5. Periodic Inspection

## 5.4.6 Check Accumulations in Exhaust System

Every 250 hours

When a diesel engine driven generator is continuously operated with less than 30% load or no load for a long time, carbon will be stuck inside the exhaust pipes, exhaust muffler, and engine body. Unburned fuel may also come out from connected portions of exhaust pipe and outlet port of the exhaust muffler. If it is continuously operated under the conditions, the fuel which comes out could ignite and cause a fire.

Further, wet-stacking and carbon accumulation could cause power drop in the engine as well as overheating, resulting a serious damage to the engine. If this occurs, eliminate the carbon accumulation by burning it under full load operation (to increase exhaust heat) until the exhaust gas becomes almost clear.

(For load current, refer to the following table as a standard value.)

Frequency	Hz	60	
Rated voltage	V	240	480
Load current	A	75	37

### CAUTION

- In case of load operation, increase load factor step by step with checking the conditions of exhaust. Do not place flammables surroundings because it could sometimes cause sparks from exhaust pipe.

## 5.4.7 Check GFCI Receptacles

Every 1 month or 250 Hours

Periodically, check the GFCI operation for safety.

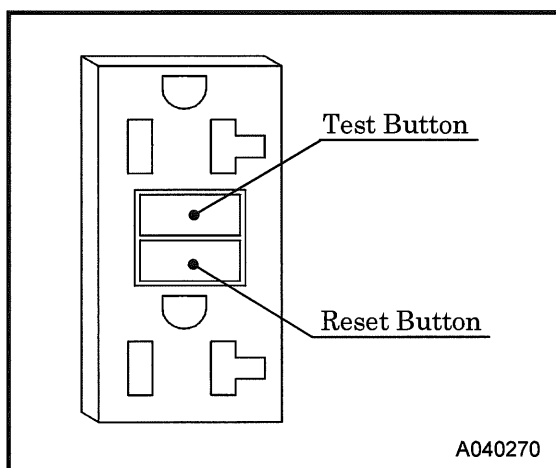

<Procedures>

1. Unplug all appliances from the generator.
2. Start the engine.
3. Turn [ON] the breaker on the instrument panel of this machine.
4. Press the test button.
5. Press the reset button.
  - The reset button should extend with a click.
  - If the reset button does not extend, contact your nearest dealer.
6. When the reset button extends during operation.
  - Unplug all appliances from the GFCI protected receptacle.
  - Press the reset button:

If the GFCI cannot be reset: The GFCI is faulty. Contact your nearest dealer.

If the GFCI resets properly: Check the appliance or the power cord.

### DANGER

- If the generator is stored outdoors, unprotected from the weather, test the GFCI receptacle before each use.
- In case the GFCI has tripped due to the hazard of ground fault currents, investigate the cause and correct it.

# 5. Periodic Inspection

## 5.4.8 Check Insulation Resistance

Every 2 months or 250 Hours

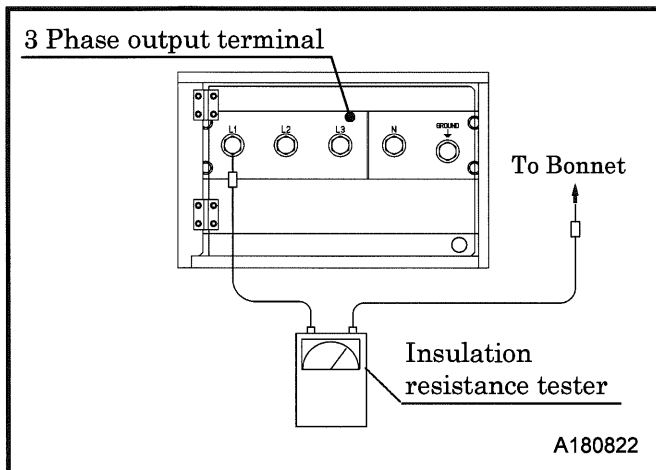

<Procedure>

1. Remove the wire from the load side of the output terminal board.
2. Loosen the mounting bolt (M6) and remove both of the [N] and [GROUND] ground wires.
3. Disconnect the AVR connector [A] inside the control panel.
4. Disconnect the connector [B] from the back of the control panel.
5. Flip the breaker [C] ON and measure the insulation resistance between the three-phase terminals L1, L2, L3 and the bonnet.
6. If insulation resistance value measured is found more than  $1M\Omega$ , it is good.
7. After checking the insulation resistance, reinstall the ground cable between [N] and [GROUND], AVR connector [A], and connector [B] at the rear side of the control panel.

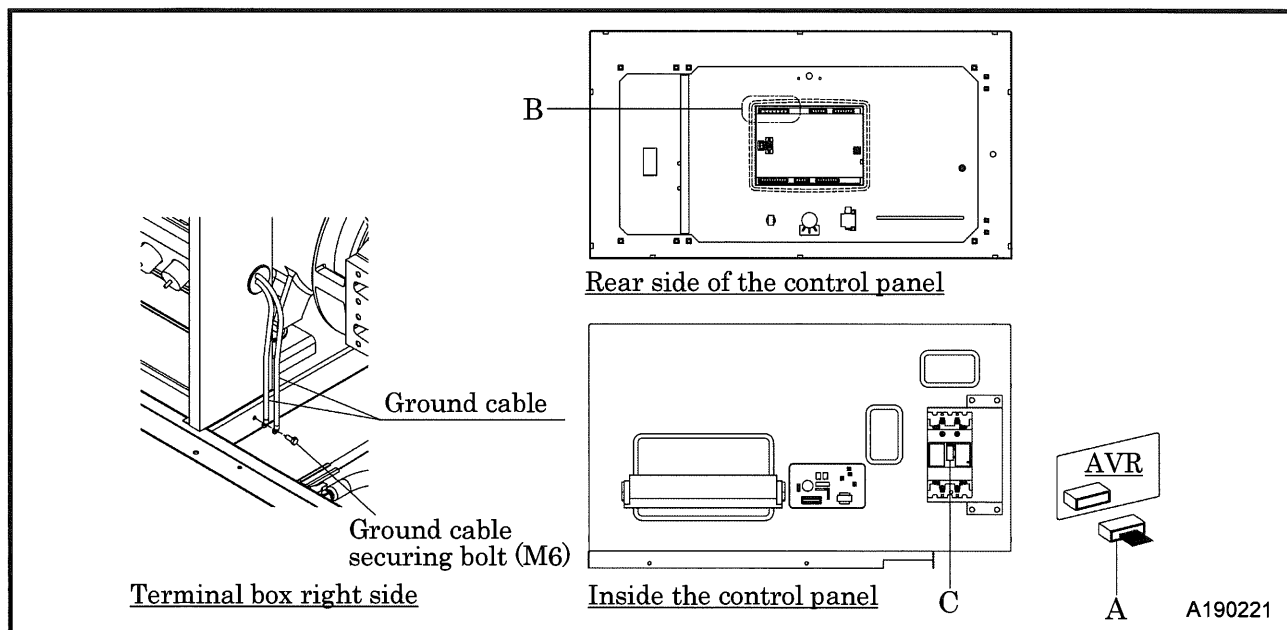

## 5. Periodic Inspection

---

### IMPORTANT

- Insulation resistance should be regularly checked or measured with a 500V insulation resistance meter. If it is reduced to lower than 1M $\Omega$ , it could cause an electrical leakage or a fire.
- For recovery or improvement of insulation resistance, wipe and clean dust and dirt around output terminals, circuit breaker, generator body outlet port and receptacle and dry them. If insulation resistance does not recover after cleaning, contact your nearest dealer.



### DANGER

- After making sure that the insulation resistance of the generator is higher than 1 M $\Omega$ , be sure to re-connect the cable between the terminal [N] and terminal [GROUND] just as it was originally connected. If it is left disconnected, the grounding becomes imperfect so that it could cause electric shock.



# 5. Periodic Inspection

## 5.4.9 Check Thermo Label on the Generator

Every 2 months or 250 Hours

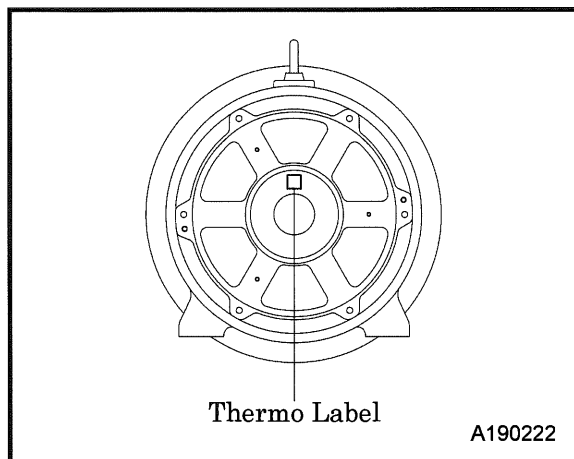

Thermo-label on the rotor bearing irreversibly changes its color from white to blue by reaching or exceeding 176°F (80°C). Be sure to check the bearing for abnormal noise and vibration if it has changed color.

- Replace discolored thermolabel after making certain that the issue is resolved.
- When replacing, contact your nearest dealer.

## 5.4.10 Drain Fuel Tank

Every 250 hours

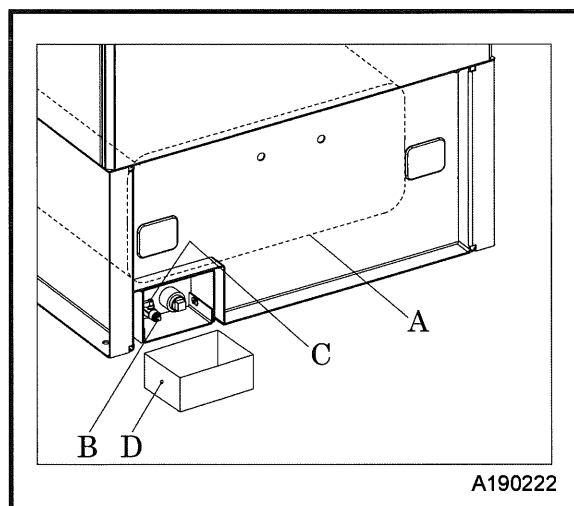

- To drain fuel tank, remove drain plug [B], and open drain valve [C] to drain the condensate accumulated in fuel tank [A].
- After making sure that all condensate is completely drained out, close drain valve [C] firmly and install drain plug [B].
- Drain oil into an appropriate container [D] and dispose of it accordingly to local rules and regulations.

## 5.4.11 Change Fuel Filter Element

Every 400 hours

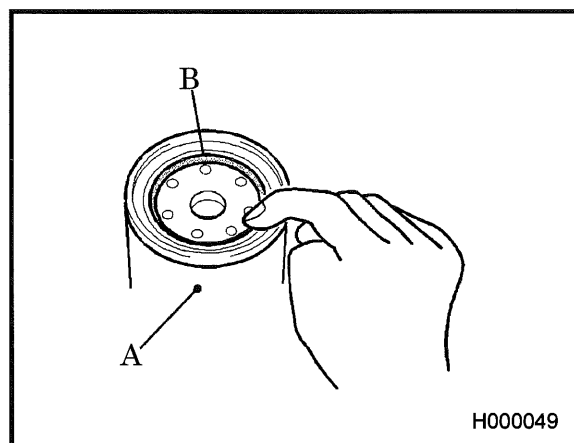

<Procedures>

1. Take out the filter case [A] using a filter wrench.
2. After thinly applying fuel on the new gasket [B], screw it in. (For part number, See 5.3)
3. After the gasket touches the sealing face, tighten another 2/3 turn with a filter wrench.
4. Remove the air from fuel. (See 3.5.5)
5. After installing the fuel filter, check it for any leak during operation.

# 5. Periodic Inspection

## 5.4.12 Change Fuel Pre-filter Element

Every 500 hours

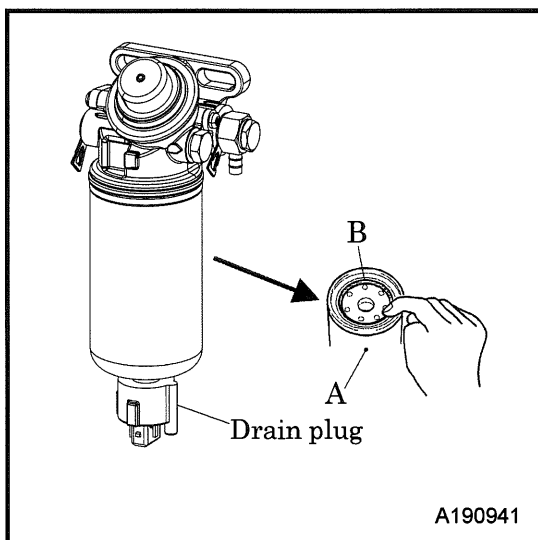

<Procedure>

1. Remove the drain plug.
  2. Prepare a container and completely drain the filter. (See 3.4.5)
  3. Take out the filter case [A] using a filter wrench.
  4. After thinly applying fuel on the new gasket [B], screw it in. (For part number, See 5.3)
  5. After the O-ring contact seal surface, tighten the case with the filter wrench.
  6. Attach the removed drain plug to the newly installed pre-filter.
  7. Remove the air from fuel. (See 3.5.5)
- Drain oil into an appropriate container and dispose of it accordingly to local rules and regulations.

## 5.4.13 Clean Outside of Radiator and Intercooler

Every 500 hours

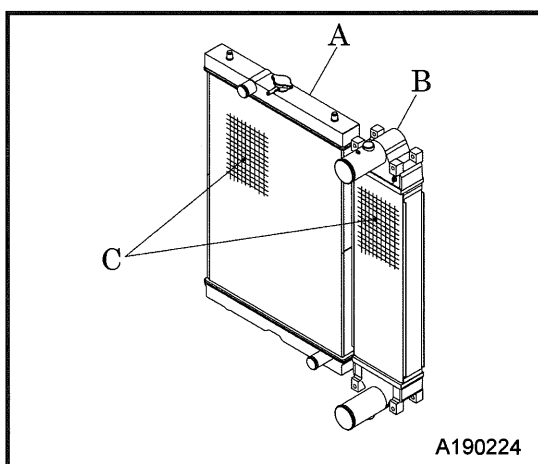

- If the fin tubes [C] of radiator [A] and intercooler [B] are clogged by dust or other foreign materials, the heat exchange efficiency drops and this will raise coolant temperature. These tubes and fins should be cleaned depending on the state of dirt inside the tubes even before maintenance schedule.
- Do not use high pressure washer for cleaning as it may damage fin tubes.
- When the unit is used or installed near seaside, clean the radiator using fresh water at least than once a month.

## 5.4.14 Drain Intercooler

Every 500 hours

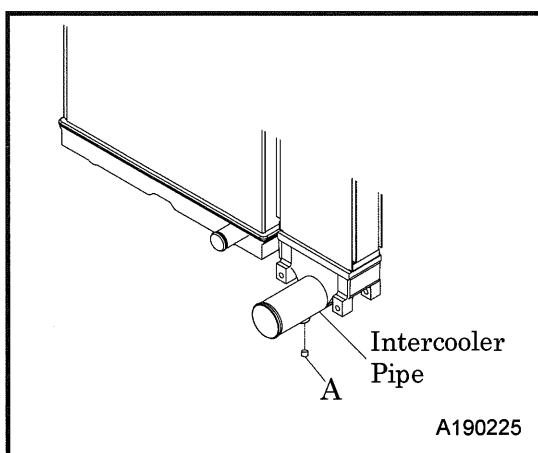

- Remove drain plug [A] below intercooler pipe to drain condensate.
- After finishing drainage, install drain plug [A].
- Drain oil into an appropriate container and dispose of it accordingly to local rules and regulations.

# 5. Periodic Inspection

## 5.4.15 Check Terminal and Wirings

Every 4 months or 500 Hours

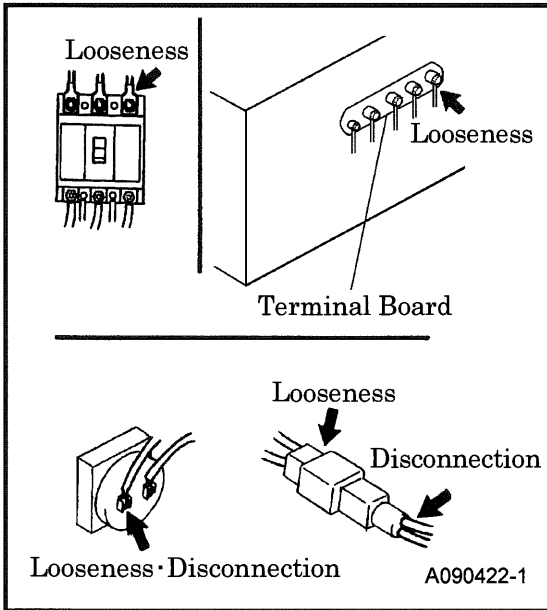

Check for any looseness on the cables, any damage on insulated covers, and disconnection, disconnected cables, or short-circuits etc.

[Checking points of electrical circuits on the generator side]

- Terminal connection of 3-phase output terminal plate.
- Main circuit of circuit breaker.
- Terminal connection on control box.
- Each terminal connection of each instrument.

[Checking points of electrical circuits on the engine side]

- Portion of connectors to the engine.
- Check for looseness of terminal connections.
- Rubbing and wear of the wire.

## 5.4.16 Check exhaust flexible pipe

Every 4 months or 500 Hours

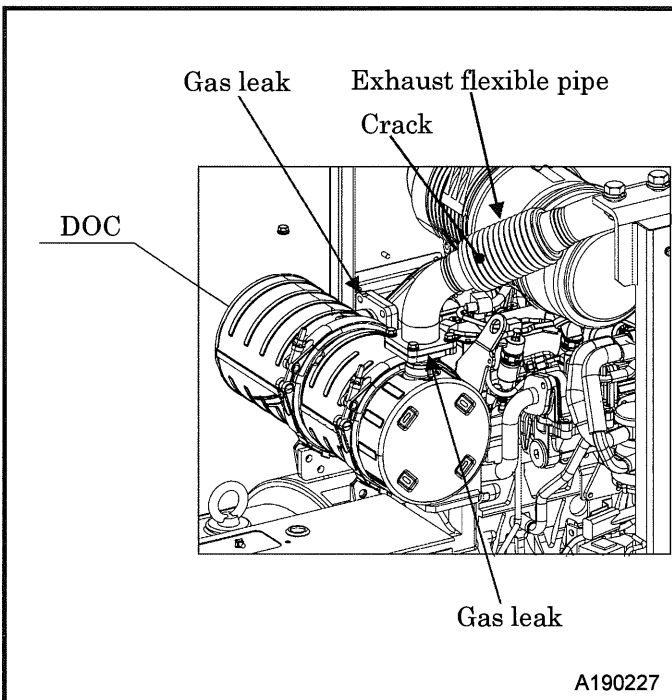

- Check the engine exhaust outlet coupler to the DOC for leaks and check for any cracks in the flexible piping.
- If any leak is found, take care to avoid getting burned by exhaust gas.

# 5. Periodic Inspection

## 5.4.17 Change Air Filter Elements

Every 1,000 hours

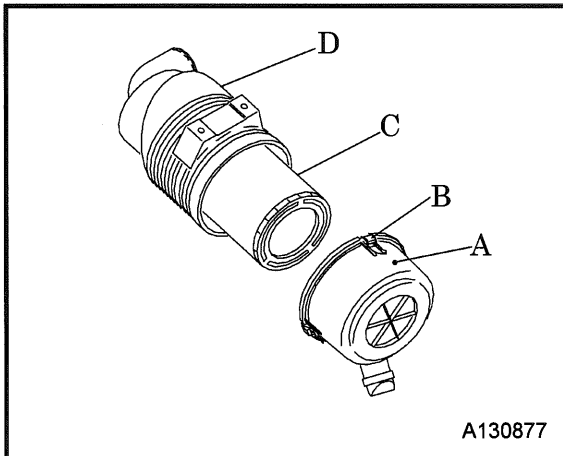

<Procedure>

1. After removing the cap [A] by loosening its cap fixing latch [B], clean its interior properly.
2. Replace filter elements [C] with new ones.  
(For part number, See 5.3)
3. When installing the cap after finishing the cleaning job, push the element into the case [D] firmly by hand, and then make sure that the cap fixing latches attach securely to the case. Lastly, tighten the latches.

### IMPORTANT

- Air filter is an important part which is crucial to machine's performance and life.  
Be sure to use genuine parts.

## 5.4.18 Replace Oil Separator Element

Every 1,500 hours

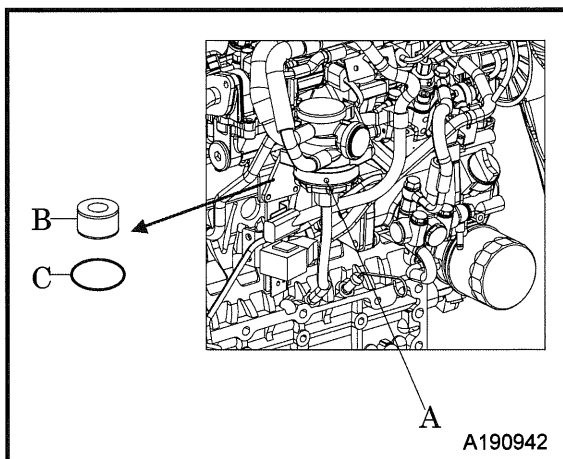

<Procedure>

1. Remove the oil separator cap [A] and remove the element [B] and O-ring [C] from inside.
2. Wipe oil out of the inside.
3. Set a new element [B] and a new O-ring [C] in the separator and reattach the cap [A].  
(For part number, See 5.3)

# 5. Periodic Inspection

## 5.4.19 Check Engine/Generator Mount

Every year or 1,000 Hours

The vibration isolation rubbers [A] are used for the support of generator and engine. Check the rubber for any damage or deterioration due to oil sticking.

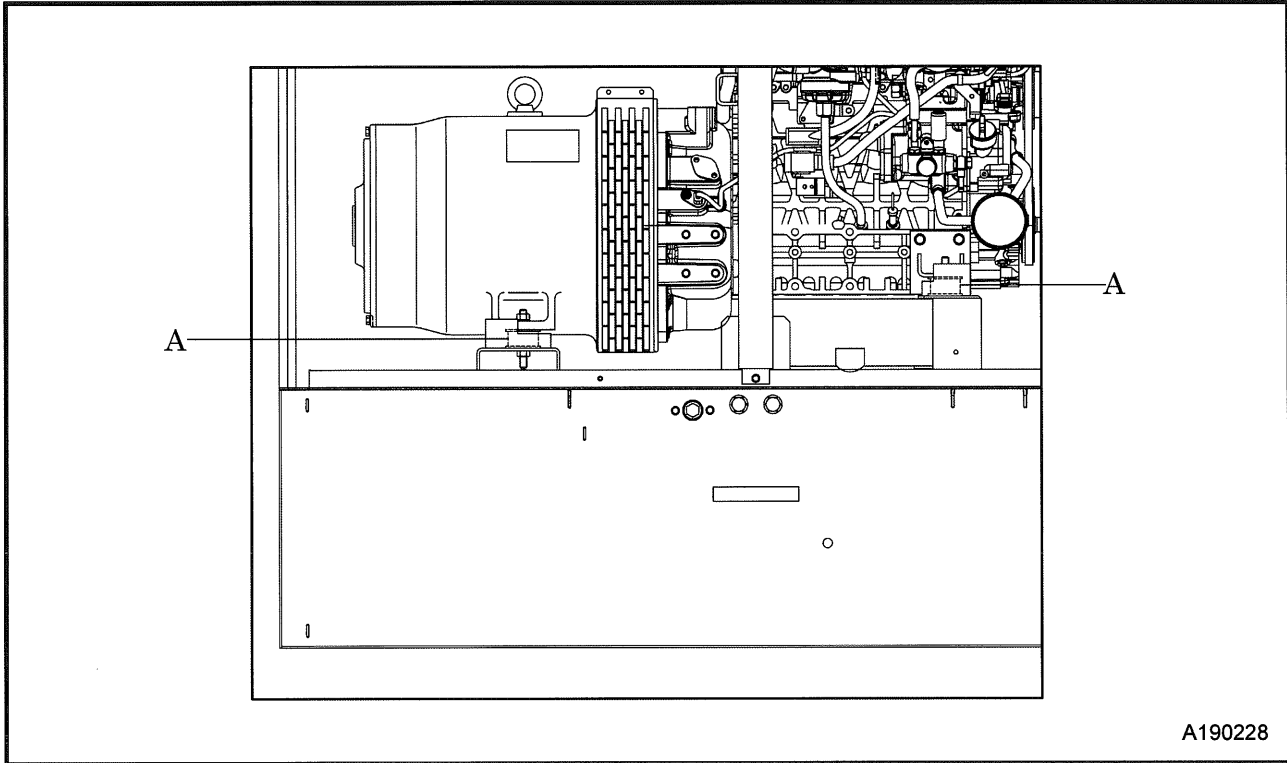

A190228

## 5.4.20 Clean the oil fence and check for rust

Every year or 1,000 Hours

Expert knowledge is required to clean the inside of the oil fence and to check it for rust. Contact your nearest dealer.

## 5.4.21 Check Each Rubber Hose

Every year or 1,000 Hours

Check all the rubber hoses for hardening, cracks, and fissures.

- If any hardening, cracks, or fissures are found on a hose (air filter, intercooler, radiator, fuel and drain), replace it with a new one.
- Check each hose clamp and if any loose hoses are found, retighten them.
- Even before the maintenance interval comes, replace hoses if hardening, cracks, or fissures are found. When replacing, contact your nearest dealer.

# 5. Periodic Inspection

## 5.4.22 Change Coolant

Every 2 years

Before replacing coolant, be sure to stop the machine and to allow sufficient time for the coolant to cool completely.

<Procedures>

1. Remove the drain cap [A] found on the top of the radiator and open the drain valve [B] to fully drain coolant from the radiator.
  2. Loosen the drain plug [C] on the engine block to drain any coolant in the engine block.
  3. Drain coolant of reserve tank.
  4. When finished draining all of the coolant, tighten and close the drain valve [B] and drain plug [C].  
Using the fill port at the top of the radiator [D], add coolant all the way to the top and then fill the reserve tank to the MAX level before reattaching the radiator and reserve tank caps.
  5. After coolant has been replaced, make sure the radiator cap and reserve tank caps are securely closed and run the unit with no load for 2-3 minutes.
  6. Stop the machine and allow coolant to cool before confirming the level of coolant in the reserve tank.
- For instructions on coolant fill procedures, please refer to section 3.4.2 of this manual.

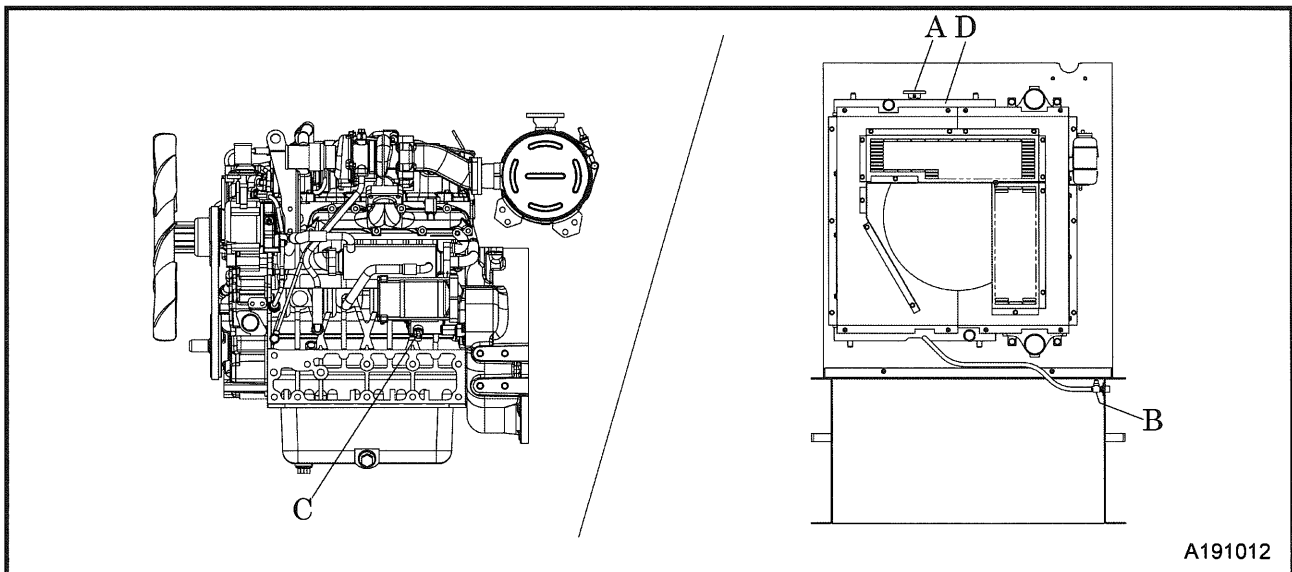

**CAUTION**

**Caution in changing coolant**

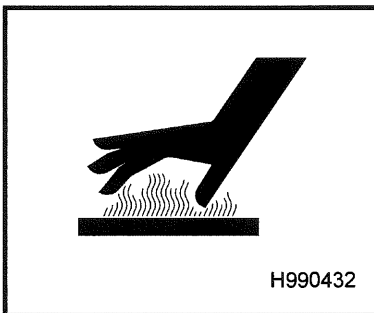

H990432

- Be sure to stop the machine and loosen the radiator cap slowly, after the coolant water is sufficiently cooled and the inner pressure is released, then take the cap off. If the following procedures are neglected, the radiator cap could be blown by the internal pressure or hot moisture air be blown out to cause burning. Therefore, make sure to carry out them without fail.
- LLC (Antifreeze) is a toxic material.
- When a person has drunk LLC (Antifreeze) by accident, make him vomit and make him see a doctor immediately.
- When a person gets LLC (Antifreeze) in his eyes, wash the eyes with clean running water and make him see a doctor immediately.
- When LLC (Antifreeze) is stored, put it in a container with an indication saying "LLC (Antifreeze) inside" and seal it up, then Keep it in a place away from children.
- Beware of flames.

# 6. Storage and Disposal

---

## 6.1 Preparation for Long-term Storage

When the machine is left unused or not operated longer than half a year (6 months), store it in a dry place free of dust after the following treatments have been done to it.

- Put the machine in an enclosure if it is stored outside. Avoid leaving the machine outside with a sheet cover directly on the paint for a long period of time, or this will cause rust to the machine.
- Perform the following treatments at least once every three months.

### <Procedures>

1. Discharge existing lubricant from the engine oil pan. Pour new lubricant in the engine to clean the internals of the engine. After running it for a while, drain it again.
2. Spread lubricant on each moving part.
3. Completely charge the battery and disconnect grounding wires. Remove the battery from the machine, if possible, and store it in a dry place. (Charge the battery at least once every month.)
4. Discharge coolant and fuel from the machine.
5. Seal air-intake port of engine and other openings like the muffler with a vinyl sheet, packing tape, etc., to prevent moisture and dust from getting in the machine.
6. Measure the insulation resistance of the generator, and make sure that it is more than 1M Ohms. (See 5.4.8)
7. Be sure to repair any trouble and maintain the machine so that it will be ready for the next operation.

## 6.2 Disposal of Product

- When disposing of this machine, first drain the cooling water and oils. If you require any additional instruction or advice, contact your nearest dealer.

# 7. Specifications

## 7.1 Specifications

Model		SDG40S-8E1			
Generator	Exciting system		Brushless		
	Armature Connection		Star with Neutral	Zig Zag	
	Phase number		3 Phase – 4 wire	1 Phase – 3 wires	
	Power Factor	%	80	100	
	Frequency	Hz	60		
	Output	kVA (kW)	36 (28.8)	28.3 (28.3)	
	Voltage	V	240	480	240/120
	Amps	A	86	43	118
Engine	Model		KUBOTA V2403-CR-TIE4BG		
	Type		4 Cycle, water cooled, direct injection, Turbocharged		
	Aftertreatment		DOC		
	No. of Cylinders		4		
	Displacement	cu.in. ( liters)	149 (2.434)		
	Output	HP(kW)	43.9 (32.7)		
	Engine Speed	RPM	1,800		
	Lubricating Oil Capacity	gal. (liters)	2.6 (9.7)		
	Coolant Capacity (including radiator)	gal. (liters)	2.5 (9.5)		
	Battery		85D26R (12V)		
	Fuel Tank Capacity	gal. (liters)	80.5 (305)		
Dimensions	Length	in.(mm)	74.8 (1,900)		
	Width	in.(mm)	38.2 (970)		
	Height	in.(mm)	61.4 (1,560)		
	Dry Weight	lbs.(kg)	2,381 (1,080)		
	Operating Weight	lbs.(kg)	2,977 (1,350)		
Others	Oil Fence Capacity	gal. (liters)	23 (100)		





# 7. Specifications

## 7.2 Outline drawing

[Unit : in.]

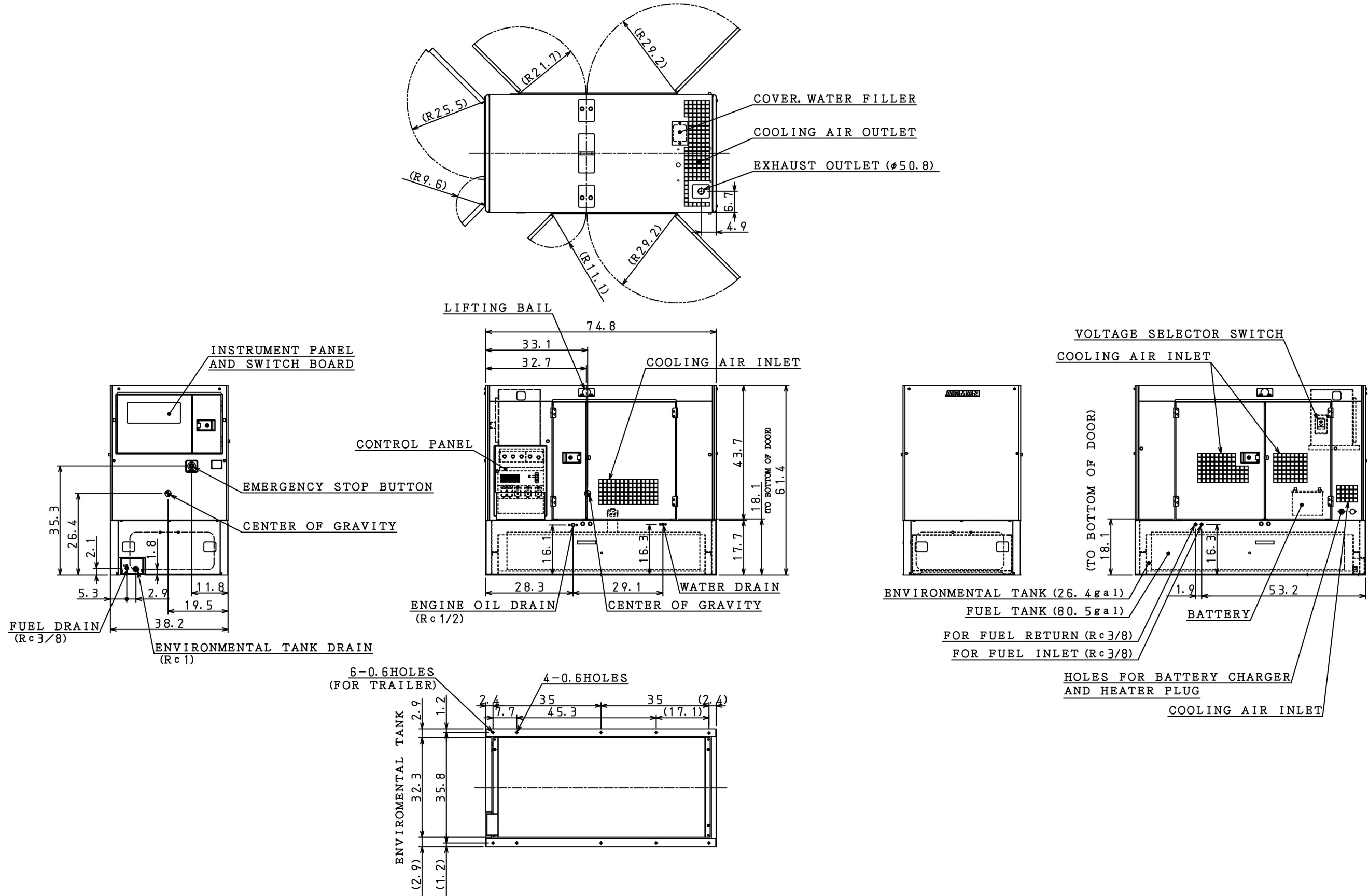

# 7. Specifications

[Unit : mm]

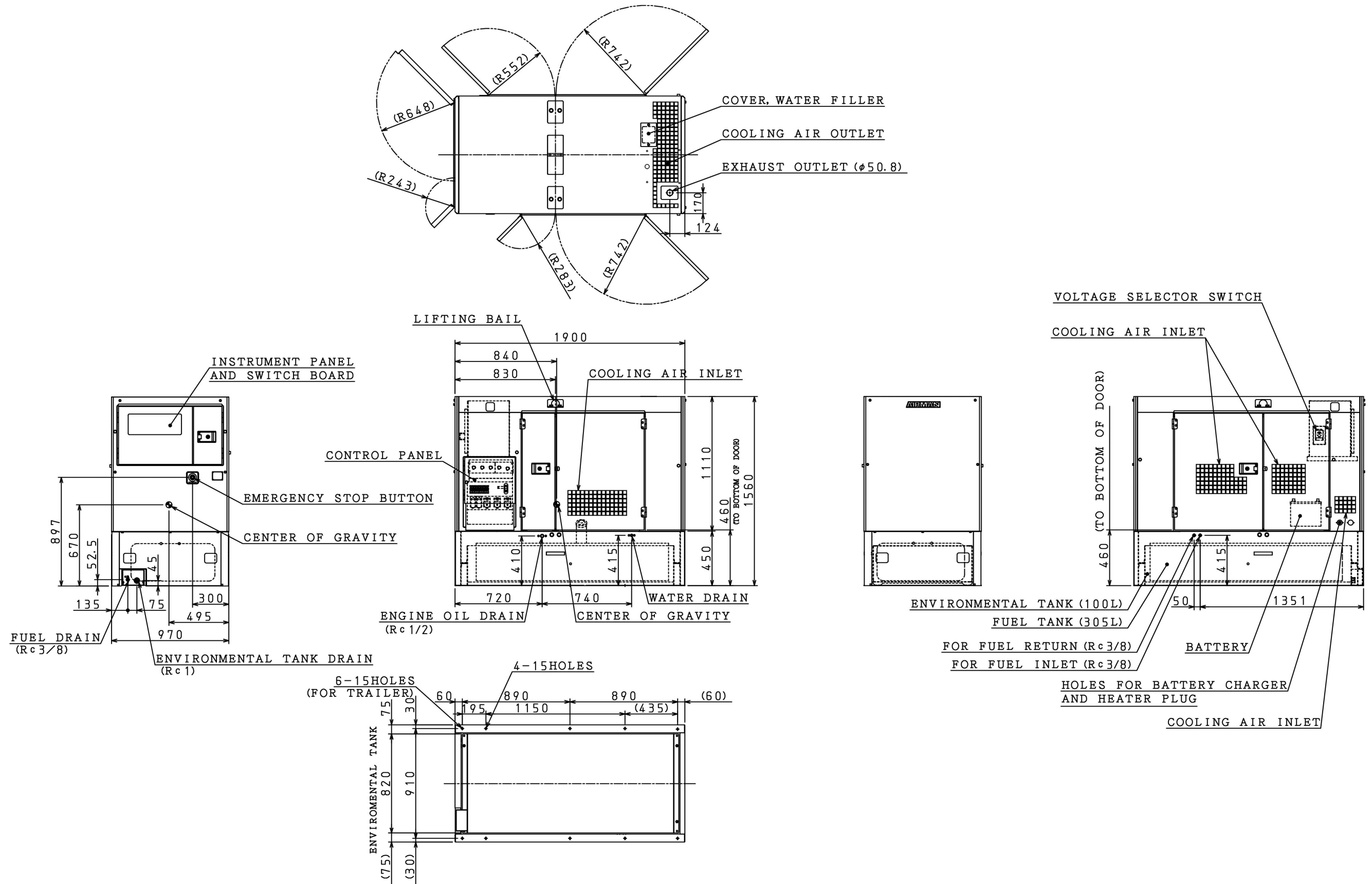

# 7. Specifications

## 7.3 Generator Wiring Diagram

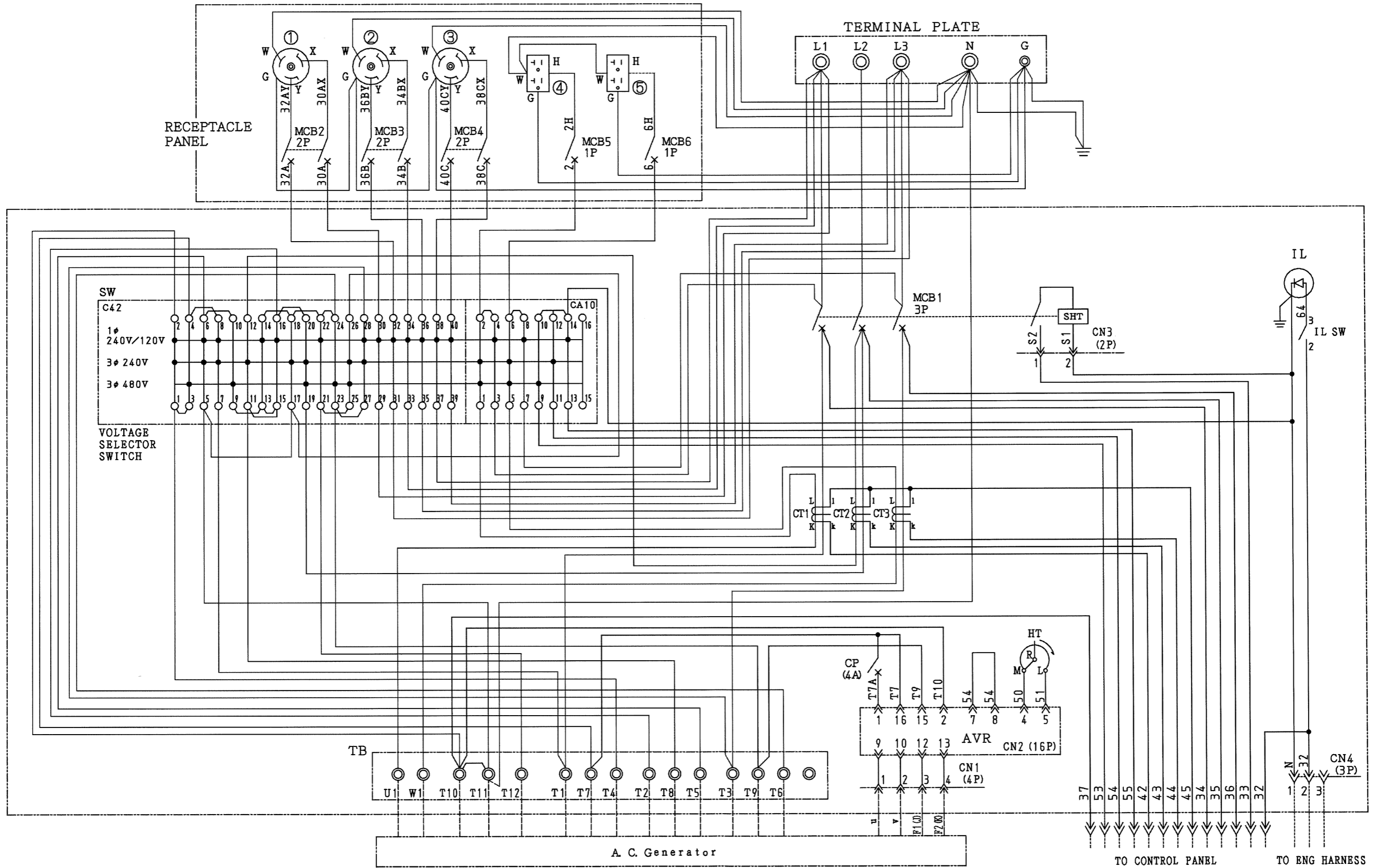

# 7. Specifications

## 7.4 Engine Wiring Diagram

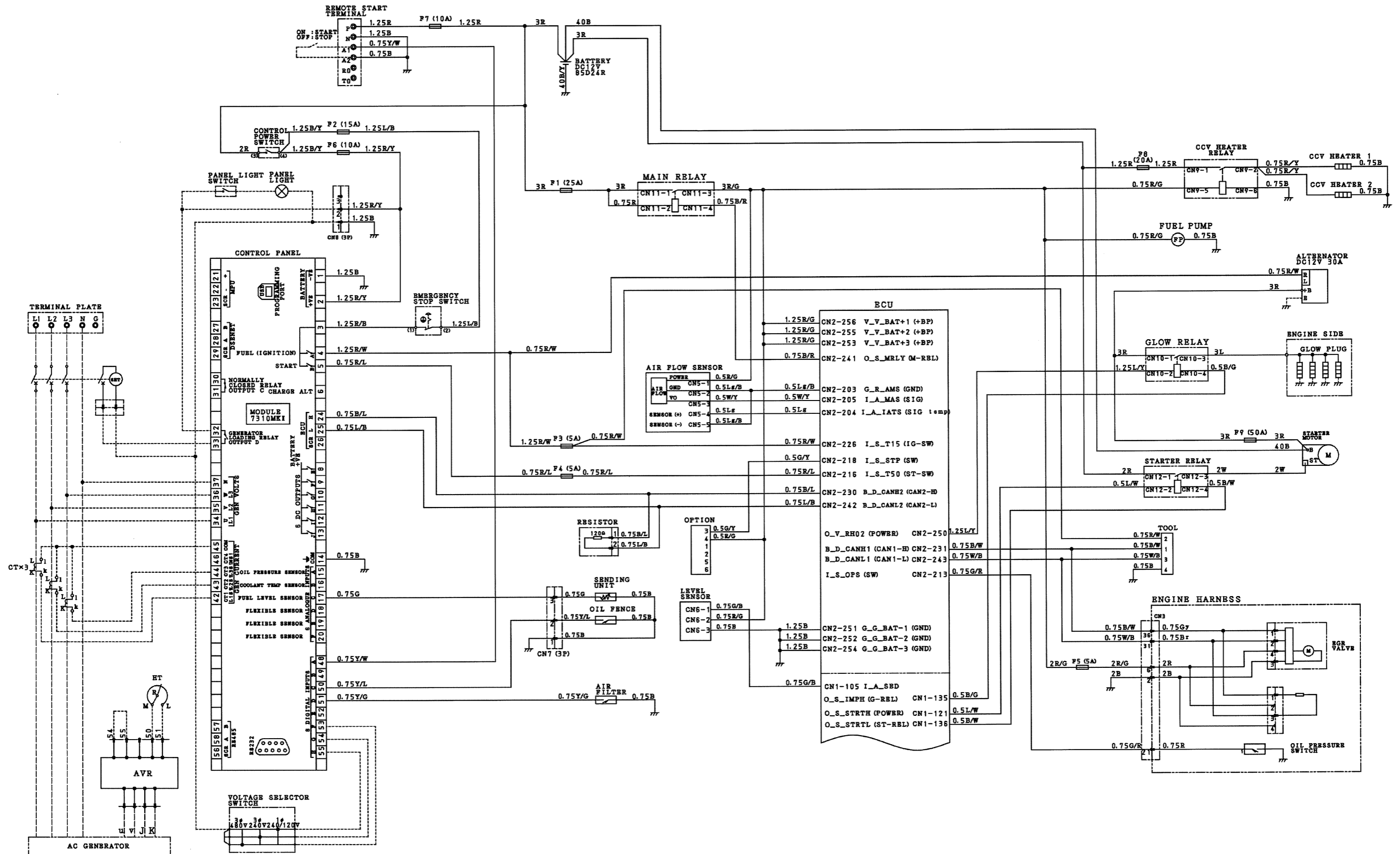

# 7. Specifications

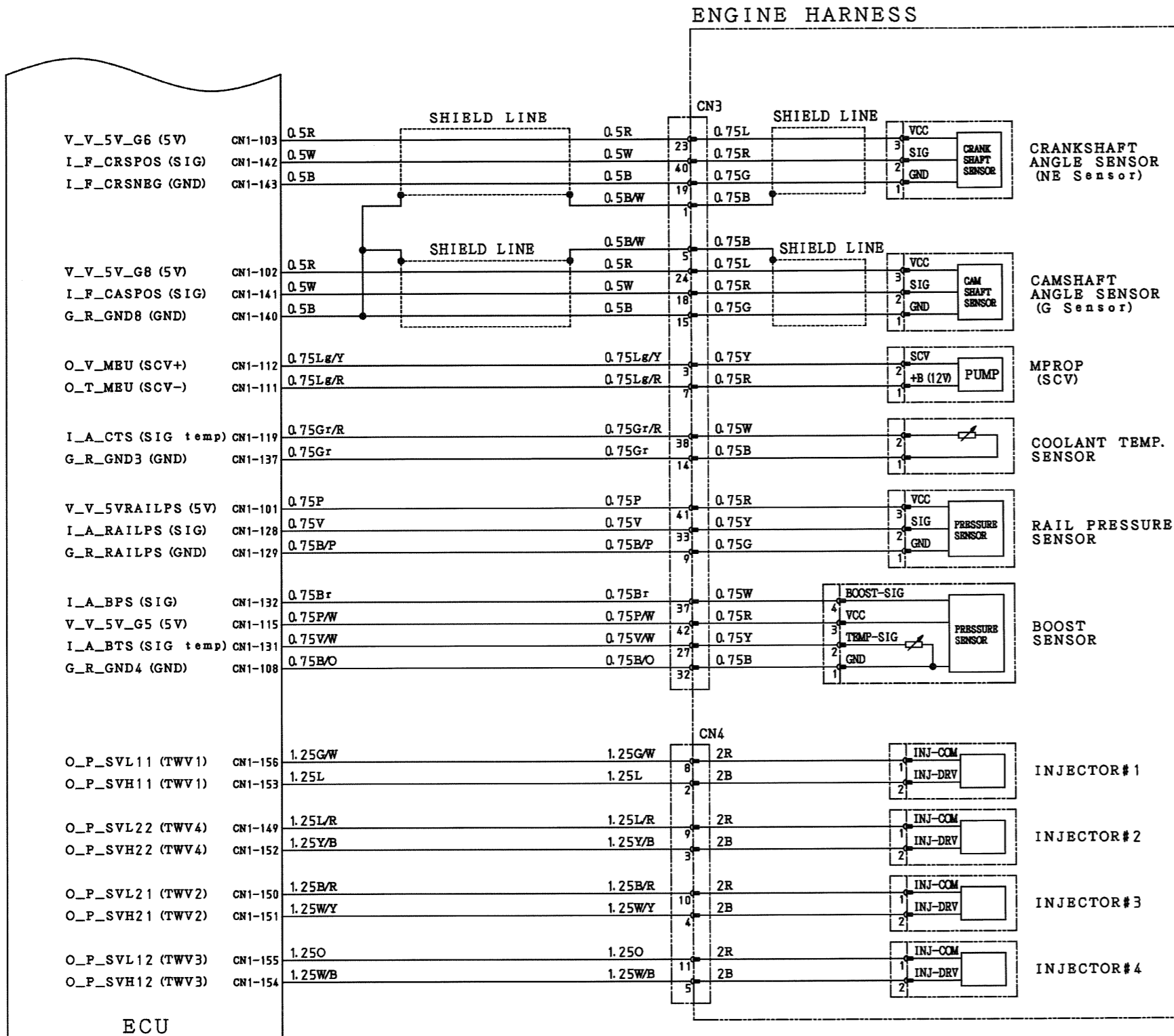

## Connector terminal arrangement

The following arrangement is seen from the side of the connector inserting port.

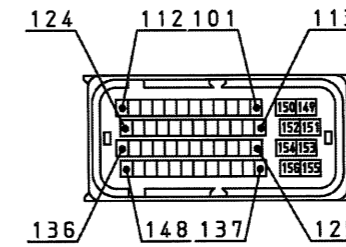

CN1

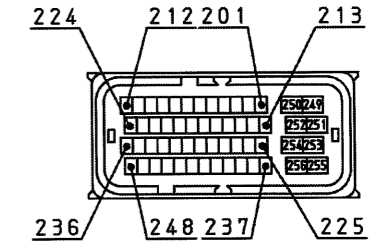

CN2

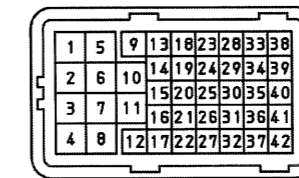

CN3

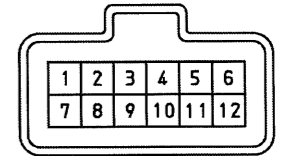

CN4

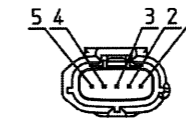

CN5

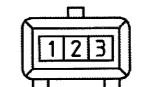

CN6

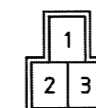

CN7

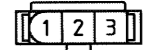

CN8

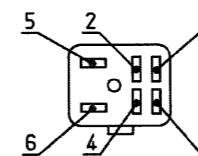

CN9

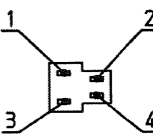

CN10

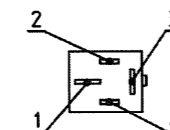

CN11, 12

# 7. Specifications

## 7.5 Piping Diagram

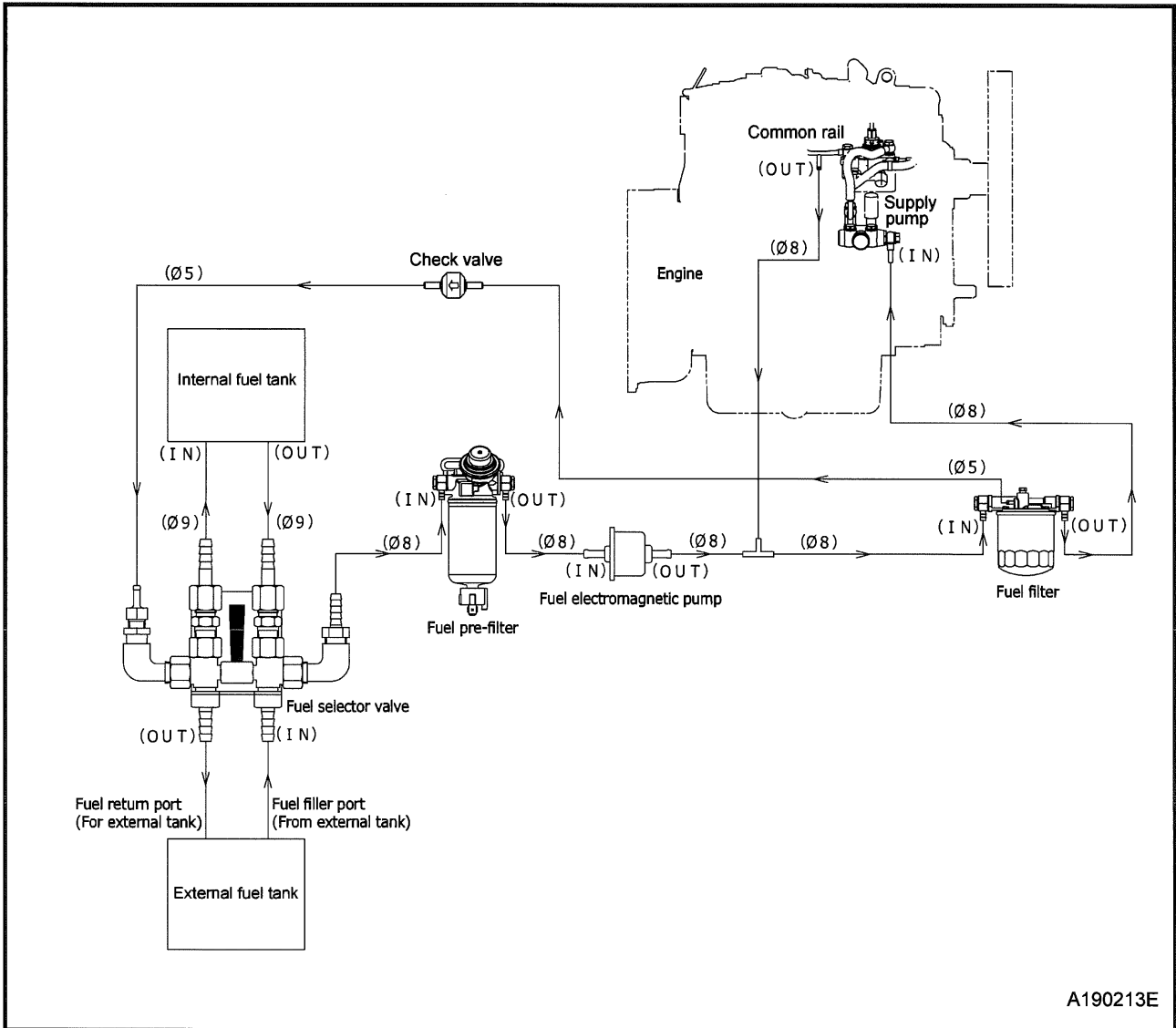

# MEMO

---

A series of horizontal dotted lines for writing.







**HOKUETSU INDUSTRIES CO., LTD.**

8TH FLOOR SHINJUKU SAN-EI BLDG,  
22-2 NISHI-SHINJUKU 1-CHOME, SHINJUKU-KU  
TOKYO 160-0023 JAPAN  
TEL:81-3-3348-7281  
FAX:81-3-3348-7289  
URL:<http://www.airman.co.jp>

Copyright (C) 2022 HOKUETSU INDUSTRIES CO., LTD. All Rights Reserved.

**39600 04451**

Printed JUN. 2024

**AIRMAN**  
HOKUETSU INDUSTRIES CO., LTD.