

AIRMAN

SG

INSTRUCTION MANUAL

ENGINE GENERATOR

SDG45S-8E2

[ENVIRONMENTAL CONTAINMENT
BASE TANK TYPE]

Please be sure to read this manual
before using this machine.

HOKUETSU INDUSTRIES CO., LTD.

Preface

Thank you for choosing "AIRMAN"

- ◆ Keep this manual at hand and refer to it as necessary.
- ◆ If this manual is missing or damaged, order a new copy from our office or your nearest dealer.
Make sure that the manual is included with the machine when it is handed over to another user.
- ◆ The contents of this manual may differ from the machine because of design changes. If anything is unclear, please contact our office or your nearest dealer for clarification.
- ◆ Refer to the Engine Operation Manual for engine handling, maintenance, and safety information.

Table of Contents



1. Major Components	1-1
1.1 Internal Components	1-1
2. Transportation and Installation	2-1
2.1 Transporting Machine	2-1
2.2 Conditions of Installation	2-2
2.3 Grounding	2-4
2.4 Selecting Cable	2-7
2.5 Fuel Pipe Selector Valve	2-8
3. Operation	3-1
3.1 Control Panel	3-1
3.2 Connecting Loads	3-3
3.3 Engine Oil • Coolant • Fuel	3-7
3.4 Before Starting the Unit	3-9
3.5 Operating Procedure	3-15
3.6 Emergency Stop	3-22
4. Failure and Troubleshooting	4-1
4.1 Protection devices	4-1
4.2 Troubleshooting	4-3
5. Periodic Inspection	5-1
5.1 Important Items at Periodic Inspection and Maintenance	5-1
5.2 Maintenance Schedule	5-2
5.3 Replacement Parts Schedule	5-3
5.4 Maintenance Items	5-4
6. Storage and Disposal	6-1
6.1 Preparation for Long-term Storage	6-1
6.2 Disposal of Product	6-1
7. Specifications	7-1
7.1 Specifications	7-1
7.2 Exterior drawing	7-2
7.3 Generator Wiring Diagram	7-4
7.4 Engine Wiring Diagram	7-5
7.5 Piping Diagram	7-7

Safety

This section explains safety precautions for operation, inspection, maintenance, installation, movement and transportation. Read these safety requirements carefully and fully understand the contents before starting the machine.

For better understanding of the precautions in this manual and on this machine, safety precautions are classified into "DANGER", "WARNING" and "CAUTION" messages with a warning symbol  marked, according to the degree of hazard.

When one of these messages is found, please take preventive measures for safety and carry out "SAFE OPERATION AND PROPER MAINTENANCE OF THE MACHINE".

 DANGER	DANGER indicates an imminently hazardous situation which, if not avoided, will result in death or serious injury.
 WARNING	WARNING indicates a potentially hazardous situation which, if not avoided, could result in death or serious injury.
 CAUTION	CAUTION indicates a potentially hazardous situation which, if not avoided, may result in minor or moderate injury. It may also be used to alert against unsafe practices.
IMPORTANT	IMPORTANT indicates important caution messages for the performance or durability of the machine, which has no concern to injury or accident of or to a human body.

This manual does not describe all safety items. We, therefore, advise you to pay special attention to all items (even though they may not be described in the manual) for your safety.

PROPOSITION 65 WARNING

 WARNING	Breathing engine exhaust exposes you to chemicals known to the State of California to cause cancer and birth defects or other reproductive harm.
	<ul style="list-style-type: none"> ● Always start and operate the engine in a well-ventilated area. ● If in an enclosed area, vent the exhaust system. ● Do not modify or tamper with the exhaust system. ● Do not idle the engine except as necessary
	For more information, go to www.P65warnings.ca.gov/diesel

Safety

- ◆ If you have any questions about the machine, please contact our office or your nearest dealer.
Be sure to have your machine's serial number to assist in providing the correct information for you.
A plate stamped with the model and serial number is attached to side of the machine.

ENGINE GENERATOR	
MODEL	<input type="text"/>
SER. NO.	<input type="text"/>
GEN. OUTPUT	<input type="text"/> kVA
VOLTAGE	<input type="text"/> V
FREQUENCY	<input type="text"/> Hz
POWER FACTOR	80% PHASE 3
RULE	JEM 1398
NET DRY MASS	<input type="text"/> kg
OPERATING MASS	<input type="text"/> kg
HOKUETSU INDUSTRIES CO., LTD.	
MADE IN JAPAN	

※ Each illustrated figure (Fig.) has a number (for instance, A040491) at the right bottom. This number is not a part number, it is an internal reference number.

A040491

Safety

[Safety Warning Labels]

Following labels are attached to the machine.

Always keep these labels clean . If they are damaged or missing, immediately place an order with your nearest dealer for replacement. Part numbers are indicated on the lower right corner of the label. Adhere a new one to the original location.

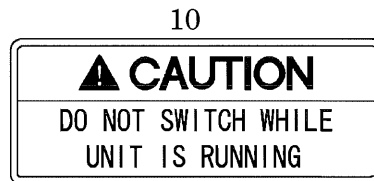
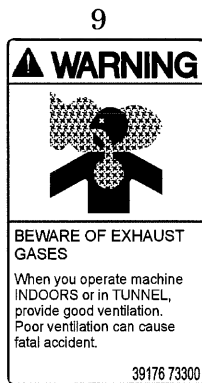
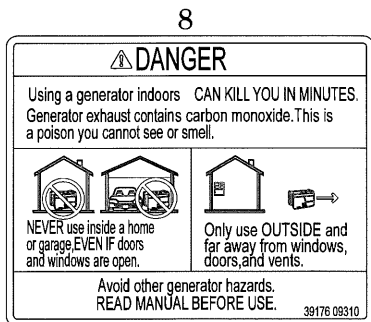
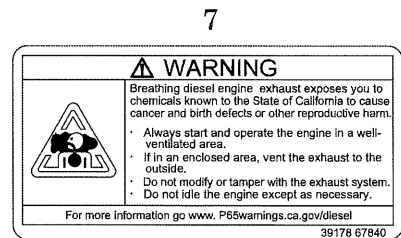
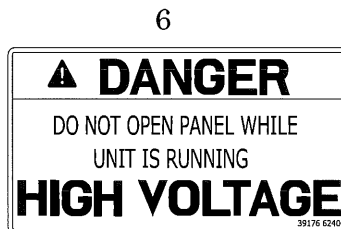
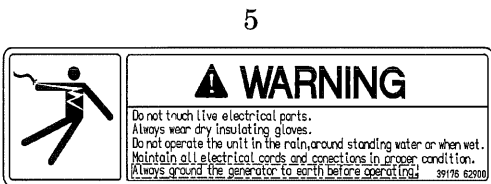
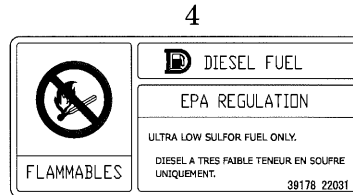
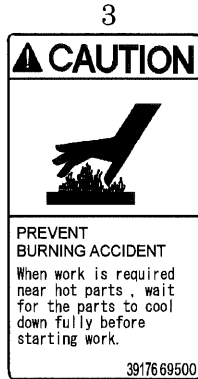
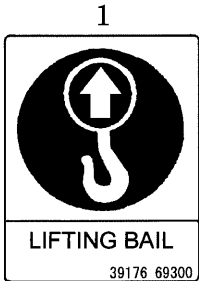

39176 50820

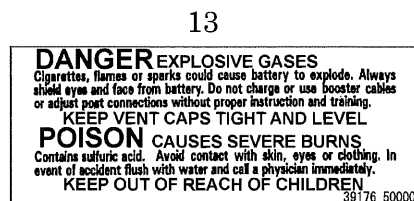
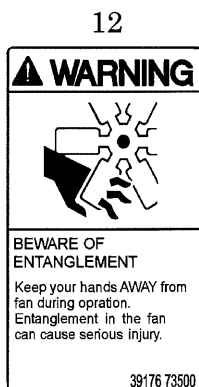

Safety

- The locations of the safety warning labels are as follows.

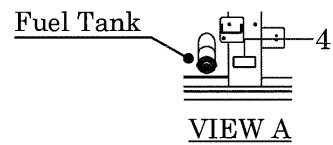
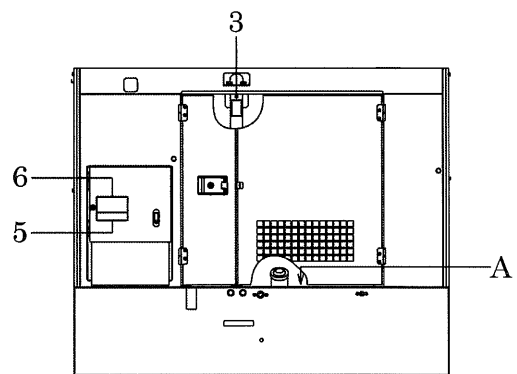
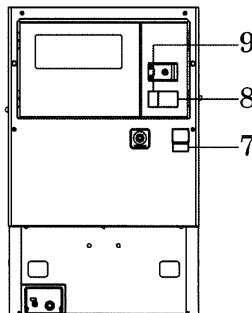
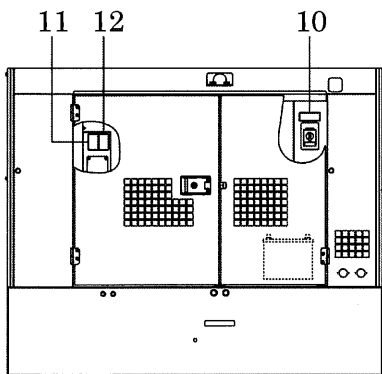
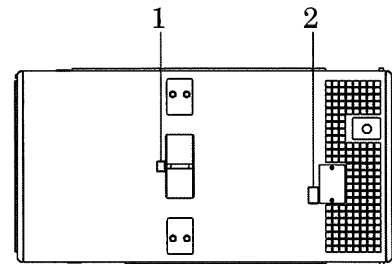
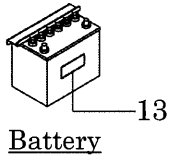

A200207

Safety

DANGER

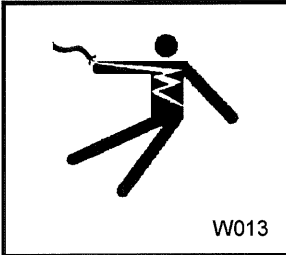

- Never touch the control panel during operation. Be aware that a voltage of several hundred volts is applied to the control panel.
- Be sure to stop the engine and turn control power switch OFF whenever the control panel has to be checked or operated. Disconnect the negative battery terminal during checking and maintenance.

WARNING

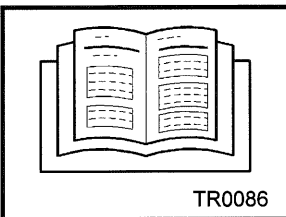

- Read each instruction plate which is displayed in the manual or on the machine carefully, understand its content and follow the indications thereof.
- Do not modify the machine without prior approval. The safety may be compromised, functions may be deteriorated, or machine life may be shortened.
- Never use the machine for the other purposes than power supply. Otherwise, serious accidents may occur.

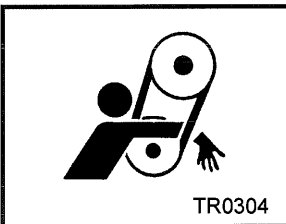

- Keep hands away from rotating components during operation.

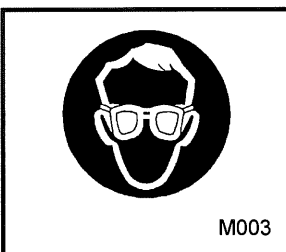

- When cleaning dust accumulated in devices such as filters, etc., with compressed air, wear safety glasses, etc. to protect your eyes

Safety

CAUTION

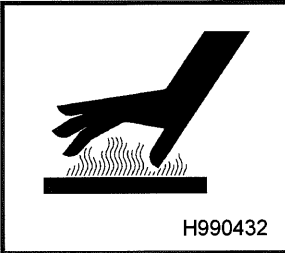

- Be sure to stop the engine and let the coolant water sufficiently cool down before draining it.
- If the drain valve is opened before the coolant water is cool enough, hot scalding water could jet out, causing burns.

- When washing the machine, cover the control panel, generator and its electric parts to prevent them from being exposed to splashing water and avoid possible decrease in electrical insulation or other troubles to the machine.
- Dust, sand, and dirt accumulated inside the control panel could cause malfunction or issues with the instrumentation. Clean them using compressed air.

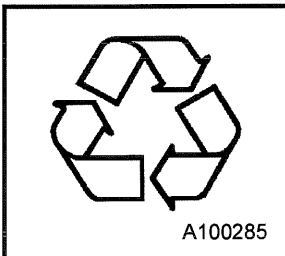

- Waste liquid from the machine contains harmful material. Do not discharge it onto the ground or into the river, lake or sea. Such material will pollute the environment.
- Be sure to use a container to hold waste liquid from the machine.
- Be sure to follow the designated regulations when disposing of oil, fuel, coolant (antifreeze), filter, battery or other harmful materials.

- The engine of this machine contains many electrical and electronic parts. Before welding, be sure to disconnect all electronic control equipment (specifically the ECM). Failure to do so could result in equipment malfunction due to excessive current.

1. Major Components

1.1 Internal Components

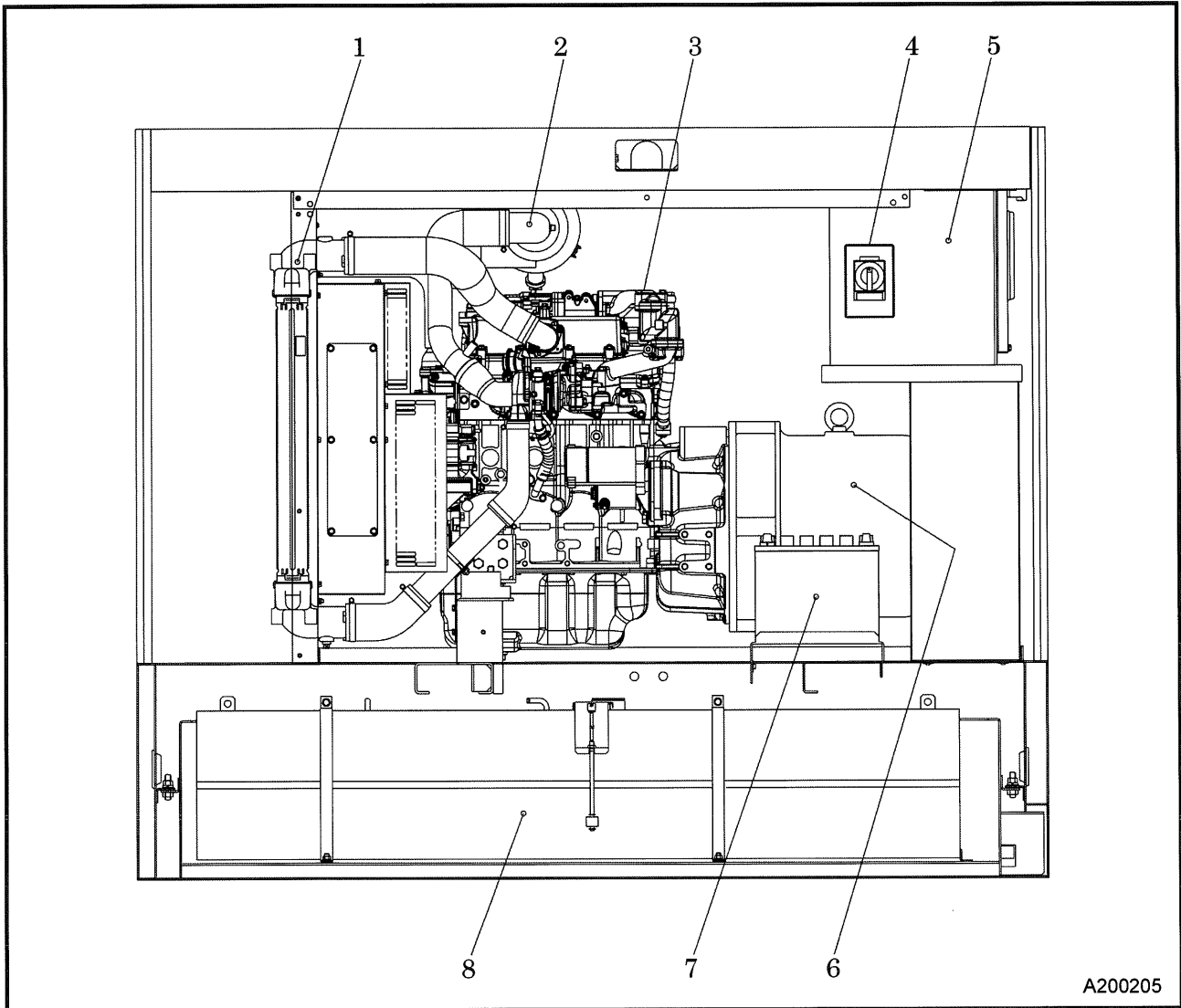

No.	Description	Function
1	Intercooler	Device that cools the air compressed by the engine supercharger.
2	Air Filter	Filtering dust from intake air.
3	Engine	Device that drives the alternator.
4	Voltage Selector Switch	Switching output voltage.
5	Control Panel (Operation Panel)	Controlling device; various meters and controls.
6	Alternator	Device that generates electricity supplied to a load.
7	Battery	Power source to start the engine.
8	Fuel Tank	Vessel for storing fuel.

1. Major Components

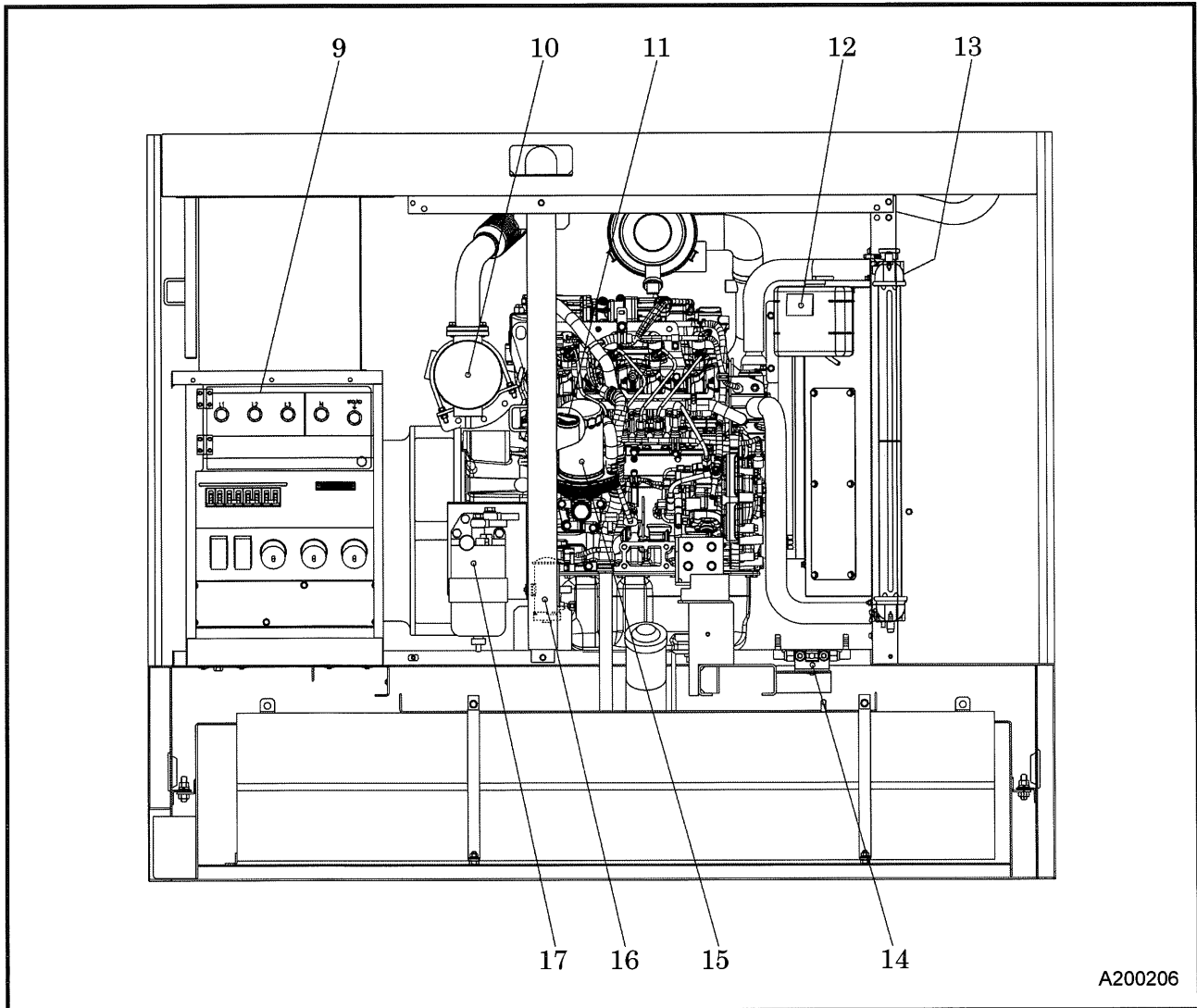

No.	Description	Function
9	Terminal Board	Outlet ports for AC power.
10	DOC (Diesel Oxidation Catalyst)	Catalyst for oxidizing exhaust gas.
11	Engine Oil Filler Port	Port for supplying / replenishing engine oil.
12	Reserve tank	Tank for checking & replenishing coolant
13	Radiator	Device that cools the engine coolant.
14	Fuel Pipe Selector Valve	Device to switch to external fuel tank supply.
15	Engine Oil Filter	Device that filters engine oil.
16	Fuel air-bleeding electromagnetic pump	Device that automatically bleeds air from the fuel lines.
17	Fuel Filter	Device that filters foreign matter & particulate mixed in fuel.

2. Transportation and Installation

2.1 Transporting Machine

- When loading and unloading machine, be sure to use the lifting bail provided on the center of the machine top.

2.1.1 Lifting

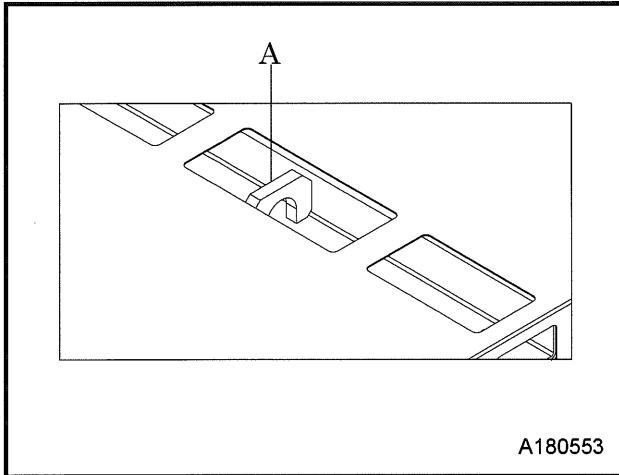

<Procedure>

1. Before lifting the unit up, make sure to check the lifting bail [A] for any cracks or loosened bolts.
 2. Connect the hook of the crane or shackle with lifting bail fitted at the top center of the unit, and make sure that there is no person standing around the unit. Then perform hoisting operation.
- Select an appropriate crane or truck by referring to the mass and dimensions mentioned in "Specifications".
 - Only a qualified crane operator is allowed to operate a crane.

WARNING Transportation

- Never go underneath the unit when suspended because it is very dangerous.
- Do not lift the unit while it is running. Otherwise, a fatal or serious accident may occur.

CAUTION

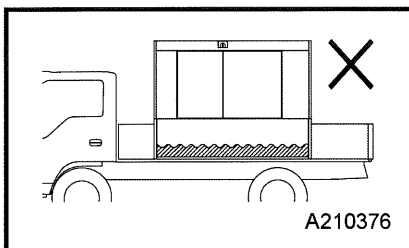

- Before transporting, check if there is condensate (fuel, oil and coolant) inside the oil fence, and if so drain it. (See 3.4.9)
- When transporting with condensate (fuel, oil and coolant) accumulated inside the oil fence, the condensate may flow out of the machine.

2. Transportation and Installation

2.2 Conditions of Installation

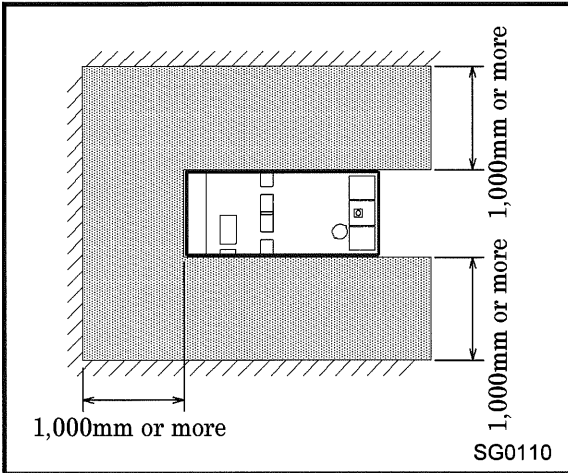

This machine should be installed only on a dry, level surface and operated in an appropriate environment as below:

- Ambient temp: 5°F to 104°F (-15°C to 40°C)
- Humidity: Less than 85%
- Altitude: Lower than 1,000m above sea level.
- ※ Using the machine outside the above conditions may cause serious failure.
- If more than two units are placed parallel in operation, keep enough distance so that exhaust air from the one does not affect the other one.
- Keep enough space around the unit for inspection and maintenance access.

WARNING

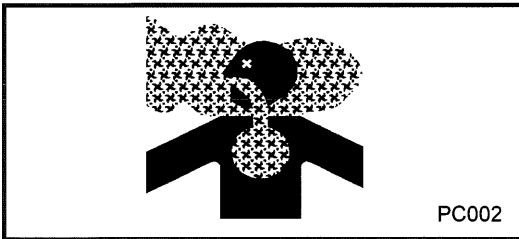

- Exhaust gas can cause death or serious injury upon inhalation. Avoid using the machine in an insufficiently ventilated building or a tunnel.
- Do not position the exhaust gas outlet in the direction of a person or a house.

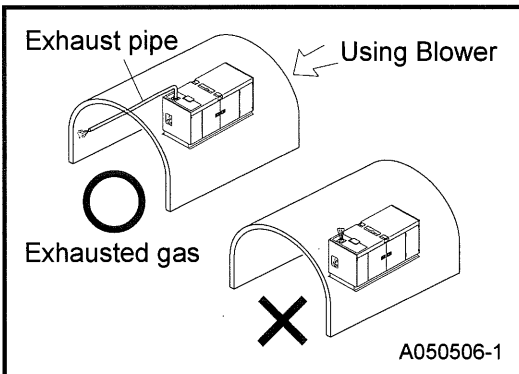

- If the unit is installed inside any tunnel, make sure to provide fresh air and ventilate it.
- In this case, make sure to extend the exhaust fume pipe outdoors, and also make sure to prevent any leak from any connection pipes.

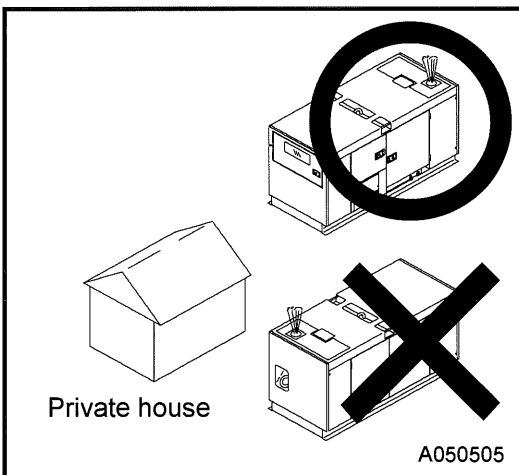

- Never locate the unit with the exhaust muffler facing any private house.
- As the exhaust gas from the engine is poisonous, never direct it at people passing by.

2. Transportation and Installation

WARNING

In case that the machine is installed indoors

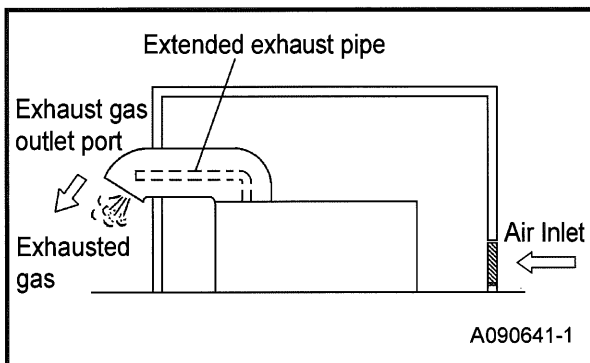

- When installing indoors, both an intake port and an exhaust port must be used to improve air ventilation.
- Make sure to secure enough space in front of air suction port and to secure it after exhaust fume outlet port so that the engine will not get overheated.
- An exhaust pipe or the like should be provided at the exhaust outlet port to send exhaust fumes outdoors.
- The cooling air outlet port of radiator should have access to the outdoors through a duct or the like for air ventilation.

CAUTION

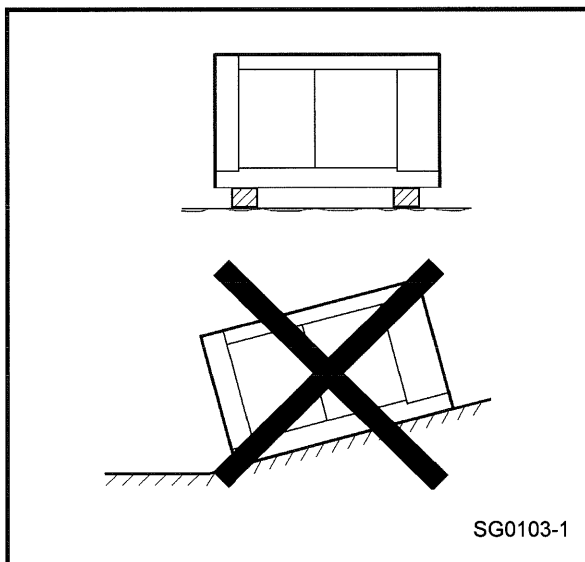

- The unit should be installed within 5° degree inclination.
- If installation site is not flat, put square bar under the unit to install it horizontally.
- Avoid installing the unit in a damp place or a place where water collects. Such an installation could cause electric shock.
- When installing the unit at the seashore, make sure that it is not exposed directly to sea water because there is a risk of the change to the insulation resistance of the generator assembly or control panel inside. To request a model with measures against salt damage, please consult the nearest sales office.
- When installing the unit at a sandy place, make sure that exhaust from the generator or radiator does not blow the sand up in the air or into the machine.

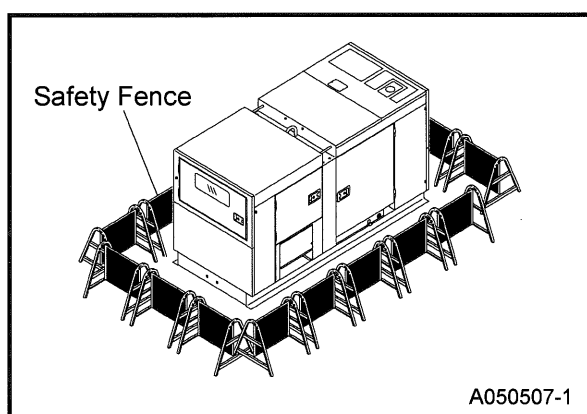

- To prevent unauthorized personnel on the job site from using or interacting with the machine, please take precautions such as safety fencing around the unit.

2. Transportation and Installation

2.3 Grounding

2.3.1 Ground Terminal

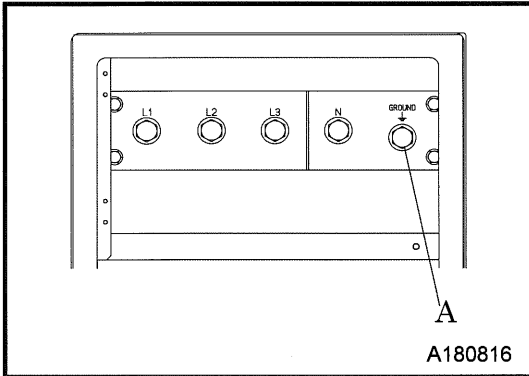

- The ground terminal [A] on the AC output terminal board is connected to ground of this unit and to the ground terminals of each outlet.

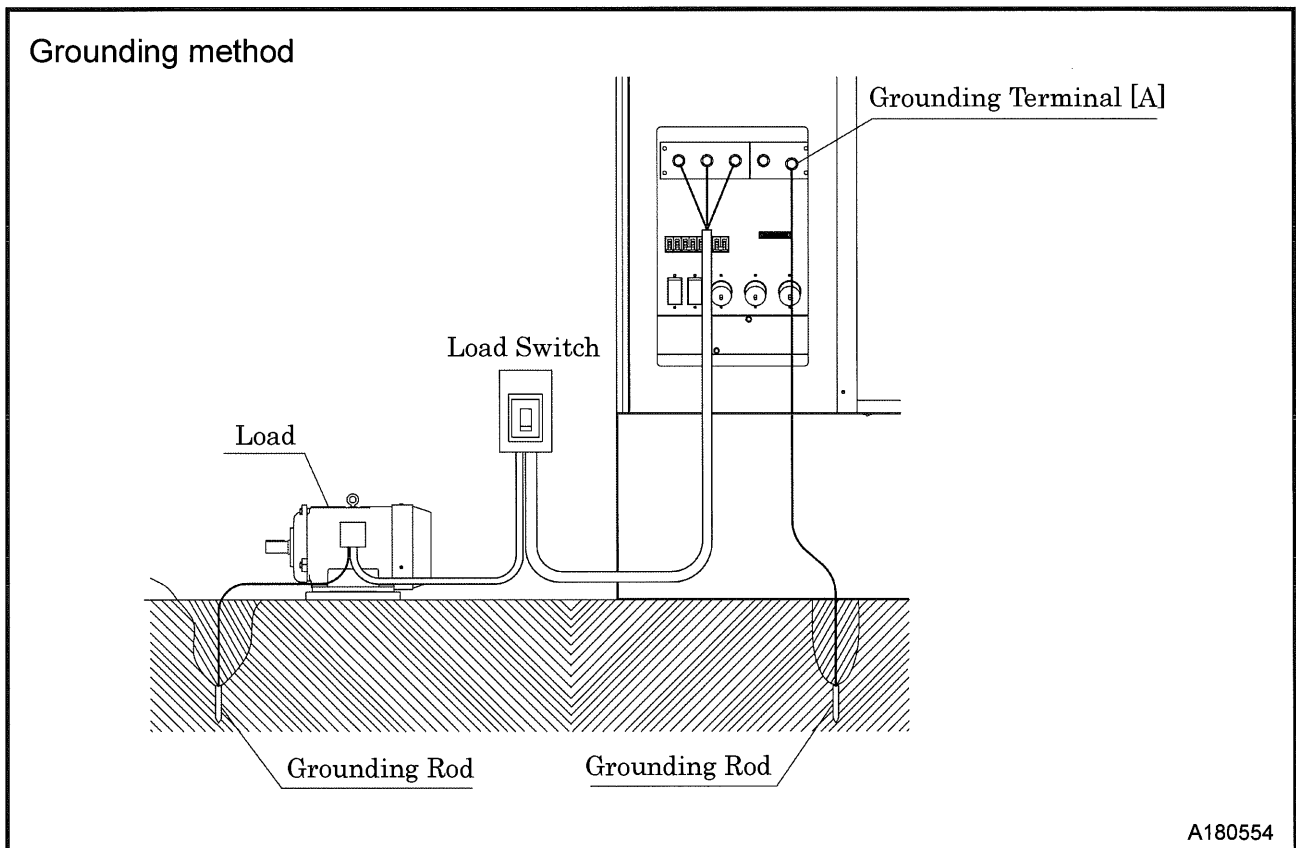

2.3.2 Grounding System

AIRMAN's generators have a system ground that connects generator frame components to the ground terminals in the AC output receptacles. The AC neutral wire (N) is connected to the system ground.

2. Transportation and Installation

2.3.3 GFCI Receptacles

- All of the 20 ampere 120 volt receptacles on the generator are protected by a GFCI (Ground-fault circuit interrupter) for protection against the hazards of ground fault currents.

An example of ground-fault current is the current which would flow through a person who is using an appliance with faulty insulation and, at the same time, is in contact with an electrical ground such as a plumbing fixture, wet floor, or earth.

- The ground-fault circuit interrupter will not protect against short circuits or overloads. The circuit breaker in the control panel which supplies power to the circuit provides that protection.
- The ground-fault circuit interrupter can be identified by the TEST and RESET buttons. The receptacles on the GFCI can be tested with the TEST and RESET buttons.

TEST BUTTON: To test, depress the "TEST" button. (Power is turned off)

RESET BUTTON: To restore power, depress the "RESET" button.

- Perform this test monthly or every 250 hours operation, whichever comes first, in order to ensure proper operation of the GFCI receptacle.

If the generator is stored outdoors, unprotected from the weather, test the GFCI receptacle before each use. Record your test on the GFCI test card provided on the control panel.

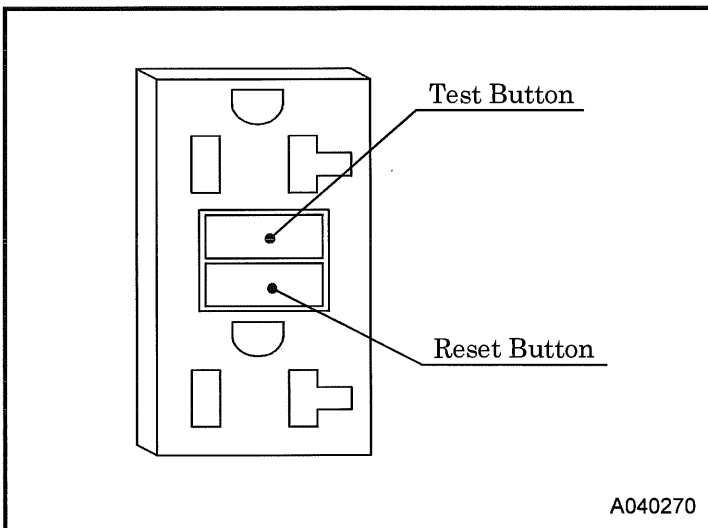

CAUTION

- Using the generator in rain, snow or near water can lead to death from electric shock.

2. Transportation and Installation

2.3.4 Connections to a Building's Electrical System

Connections for standby power to a building's electrical system must be made by a qualified electrician. The connection must isolate the generator power from utility power and must comply with all applicable laws and electrical codes.

CAUTION

- Improper connections to a building's electrical system can allow electrical current from the generator to backfeed into the utility lines. Such backfeed may electrocute utility company workers or others who are in contact with the lines during a power outage. For more information please consult with the utility company or a qualified electrician.
- Improper connections to a building's electrical system can allow electrical current from the utility company to backfeed into the generator. When utility power is restored, the generator may explode, burn, or cause a fire in the building's electrical system. For more information please consult with the utility company or a qualified electrician.

2. Transportation and Installation

2.4 Selecting Cable

- Select a cable with sufficient diameter by considering the permissible current on the cable and the distance from the generator to the load.
- If the current flowing to the load exceeds the permissible current of the cable, resultant overheating may melt the cable. Similarly, if the cable is too small in thickness to the length, the input voltage to the load will fall to cause the load input power to drop, as a result, the performance of the machine may be diminished.

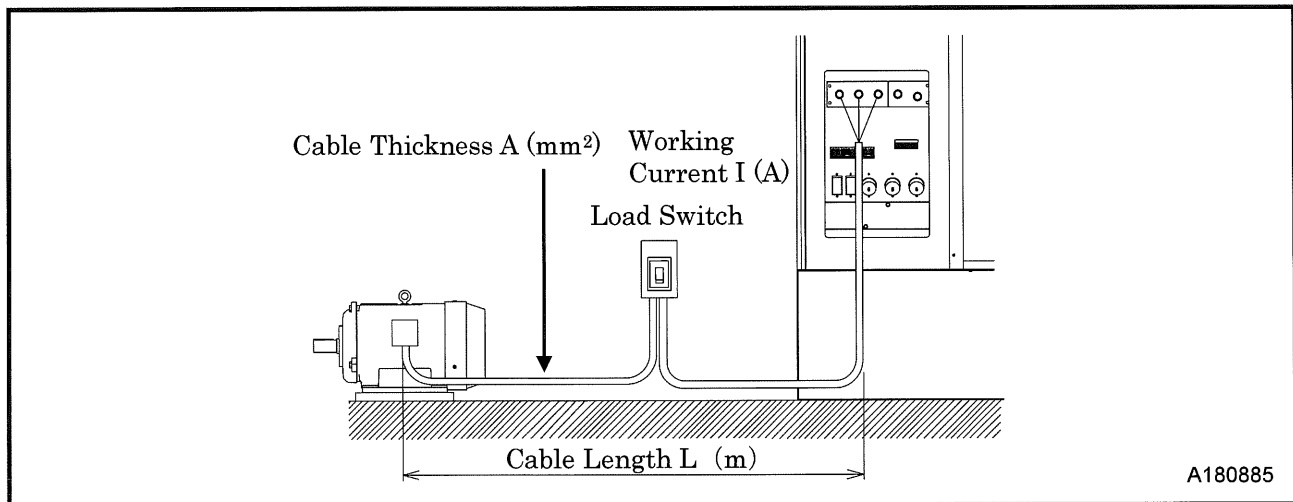

- Simplified formula to seek voltage drop or cross-sectional area of the cable from cable length and working current.
Select such a cable length and thickness so that the voltage drop will remain within 5%.

Output System	Voltage Drop	Cross-sectional area of Cable	e: Voltage drop(V) e': Voltage drop between outside line or one line of each phase and neutral line. A: Cable thickness (mm ²) L: Cable length (m) I: Working current (A)
3 Phase, 3 Wire	$e = \frac{30.8 \times L \times I}{1,000 \times A}$	$A = \frac{30.8 \times L \times I}{1,000 \times e}$	
3 Phase, 4 Wire	$e' = \frac{17.8 \times L \times I}{1,000 \times A}$	$A = \frac{17.8 \times L \times I}{1,000 \times e'}$	

- The following tables show the relations between the cable length and the cable thickness (nominal cross-sectional area) suited to the working current.
(Based on the condition that working voltage is 200 V, with voltage drop of 10V.)

Single-Conductor Cable

(Unit: mm²)

Length Current	165ft (50m)	246ft (75m)	328ft (100m)	410ft (125m)	492ft (150m)	656ft (200m)
50A	8	14	22	22	30	38
100A	22	30	38	50	50	60
150A	38	38	50	60	80	100

Three-Conductor Cable

(Unit: mm²)

Length Current	165ft (50m)	246ft (75m)	328ft (100m)	410ft (125m)	492ft (150m)	656ft (200m)
50A	14	14	22	22	30	38
100A	38	38	38	50	50	60
150A	22×2	22×2	38×2	38×2	38×2	50×2

2. Transportation and Installation

2.5 Fuel Pipe Selector Valve

2.5.1 Overview

This valve is designed to feed fuel directly from an external fuel tank or from the installed fuel tank as described below.

2.5.2 Operation method

<Procedures>

1. Machine is delivered from the factory with fuel line piping and selector valves set as shown in the following Fig.1. When operating the machine, with the installed fuel tank, run the machine with the fuel line piping and the handles of selector valves as set from the factory.
2. When using an external fuel tank, remove the plug fitted at the connections to the external tank and set the piping as shown in Fig.2.
And then turn the handles of the selector valve as shown in Fig.2.
3. When removing the external tank piping connection, make sure to return the handles to the original positions shown in Fig.1 and install the plugs.

2.5.3 Installation of External Fuel tank and piping method

<Procedures>

1. Use oil resistant hoses with an inside diameter of 8mm to 10mm.
2. Install the fuel tank so that the fuel level of the tank is between 0 and 2.5m high from the machine installation level.
3. To avoid suction of water and sediment together, install the suction pipe so that the inlet port of suction pipe may be kept between 15mm and 20mm higher than the bottom line of the tank. Also install the outlet port of the return pipe inside the tank. (See Fig.2·A)
4. When refueling the tank, take caution to prevent water and particulate ingress.

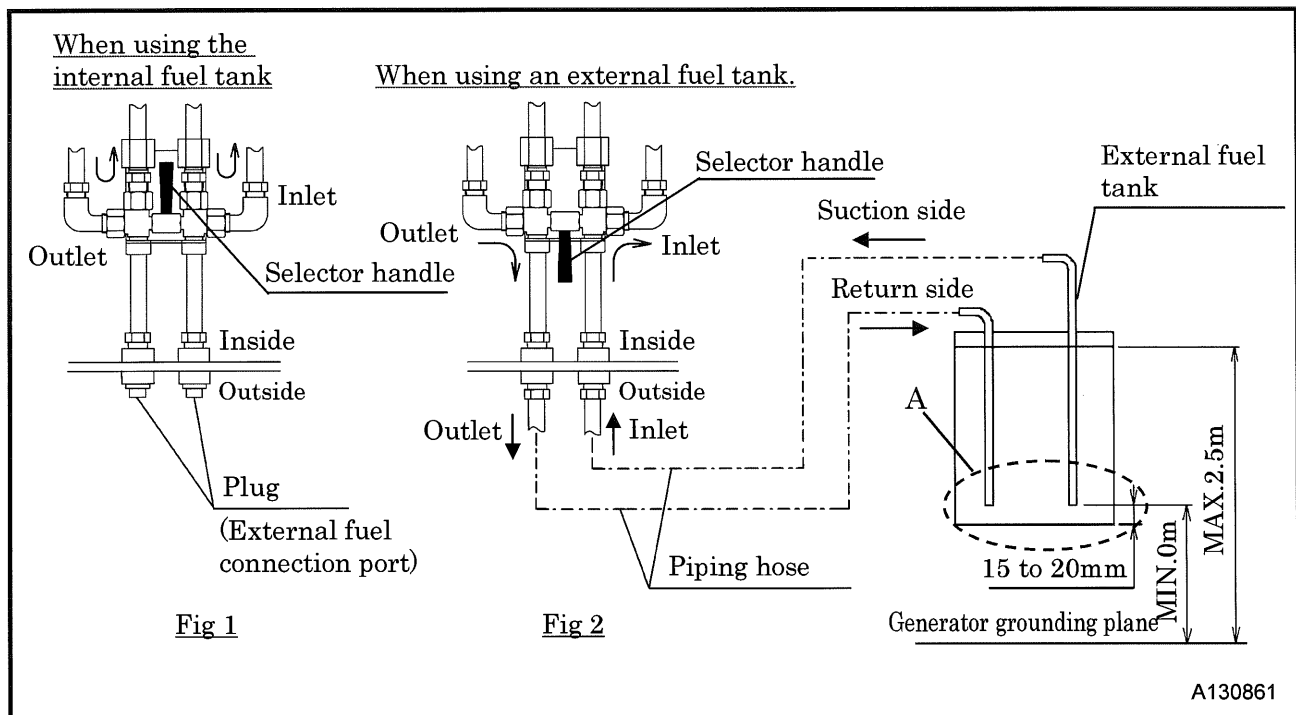

2. Transportation and Installation

 **CAUTION**

- Always watch the fuel supply conditions when supplying fuel from an external fuel tank. Make sure to change the handles of the selector valves to the predetermined positions.
If you make a mistake in turning the handles, it can burst the fuel pipe and cause overflowing. It could lead to a serious accident.
- Take great care not to use excessive force on the selector valve handle. It may cause damage or fuel leakage.

3. Operation

3.1 Operation Panel

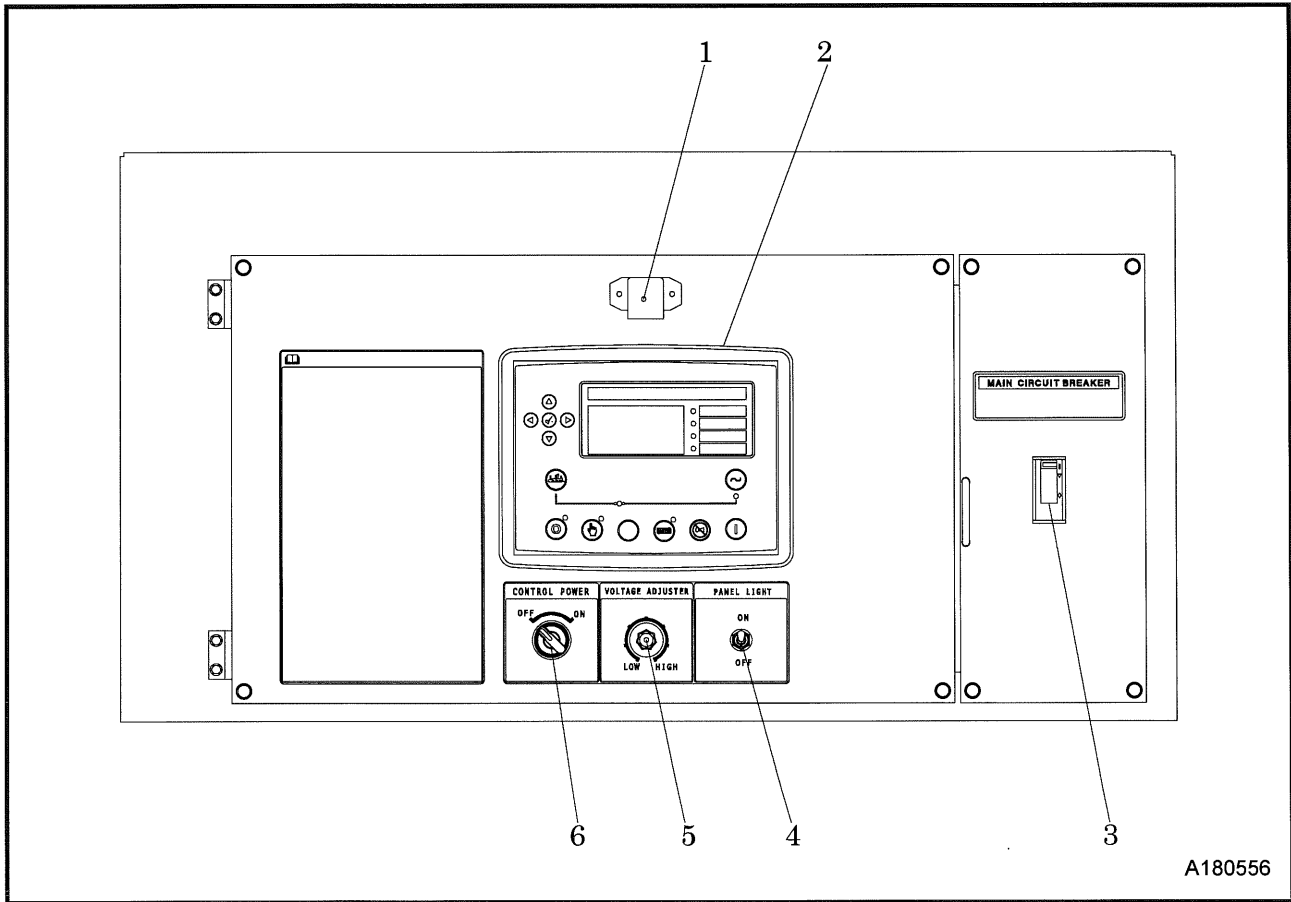

- 1. Panel Light
- 2. Control Panel
- 3. Circuit Breaker

- 4. Panel Light Switch
- 5. Voltage Adjuster
- 6. Main Power Switch

A180556

3. Operation

Control Panel

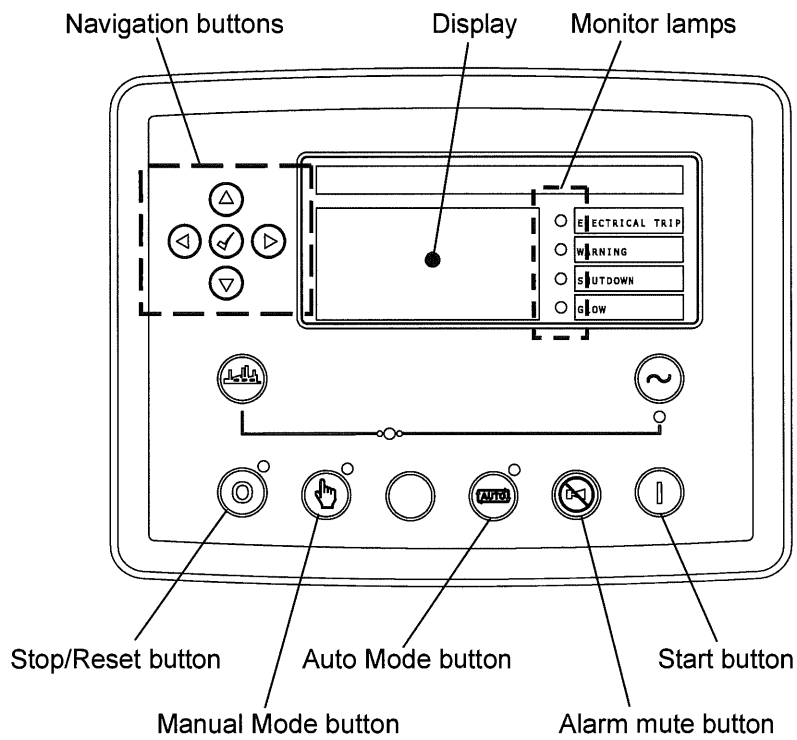

A180097E

[How to switch between display screens]

1. By pressing the ◀ or ▶ arrow buttons you can cycle between the categories on the screen.

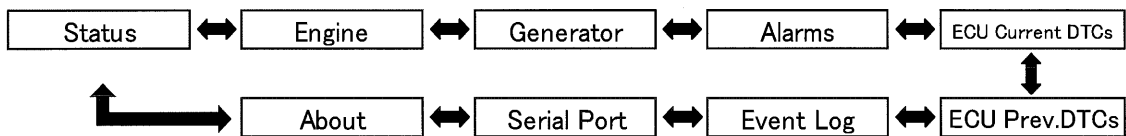

2. By pressing the ▲ and ▼ arrow buttons each categories input parameters can be verified (input parameters vary by unit model).

3. Display will return to main screen if no commands are entered for three minutes.

3. Operation

3.2 Connecting Loads

Select a cable with sufficient diameter by considering the load capacity and the distance from the generator to the load. Use round terminal affixed cables for connection and securely fasten them. (See 2.4)

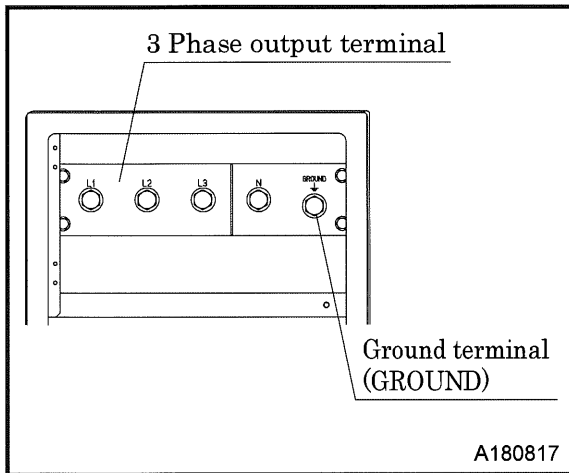

- After checking phase number and voltage of the required load, make sure to connect them correctly.

---Terminal Size---

3 Phase output (L1·L2·L3·N)	M14
Ground terminal (G)	M14

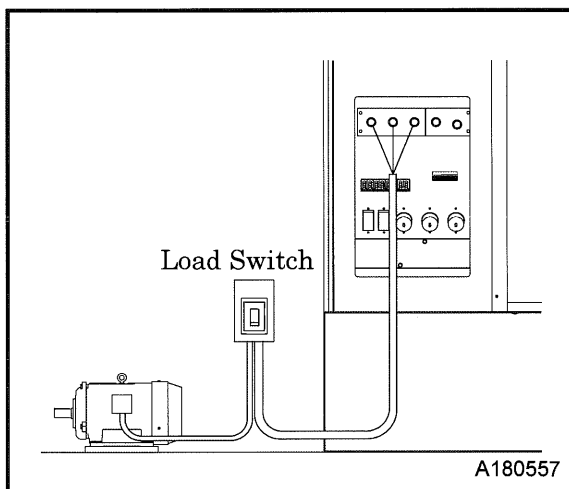

- Install a load switch between the output terminal and the load. Do not use the generator's circuit breaker to directly switch the load on/off. It may cause damage to the circuit breaker.
- Connect the connecting cable to the load so that the output terminals do not touch each other.

⚠ WARNING

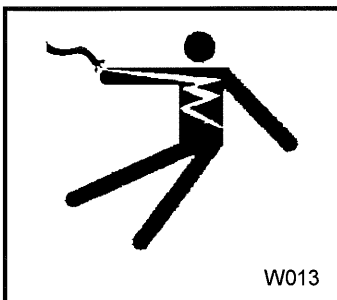

- When removing or attaching a connecting cable for changing load, be sure to switch OFF the generator's circuit breaker, as well as removing the key to ensure the unit is stopped before performing work.
- When attaching a connecting cable to a load, do not use a cable with damaged sheath nor an inappropriate insulation cable to the voltage. Secure connections between each cable terminal and input/output terminal. Otherwise, it may become loose during operation and may cause a fire or an electric shock accident.

3. Operation

3.2.1 Output Terminal connections

- Voltage is selected with the voltage selector switch.

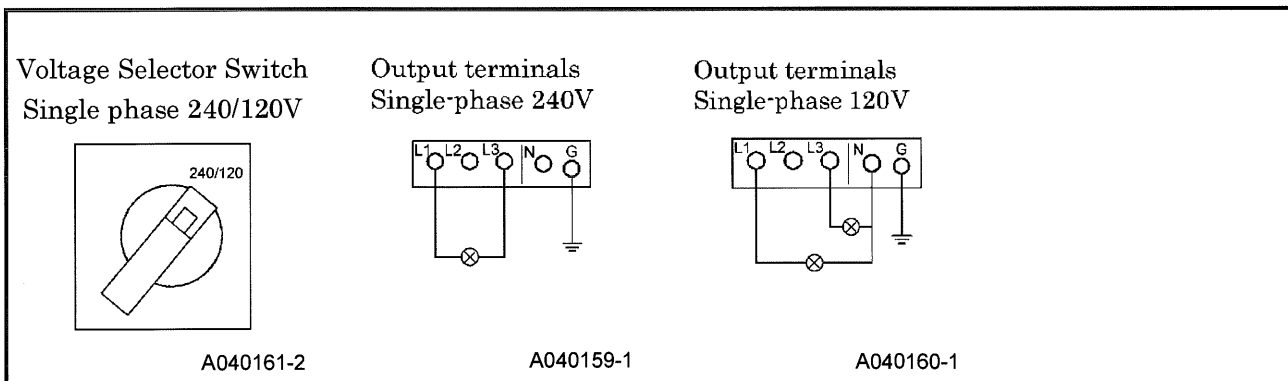
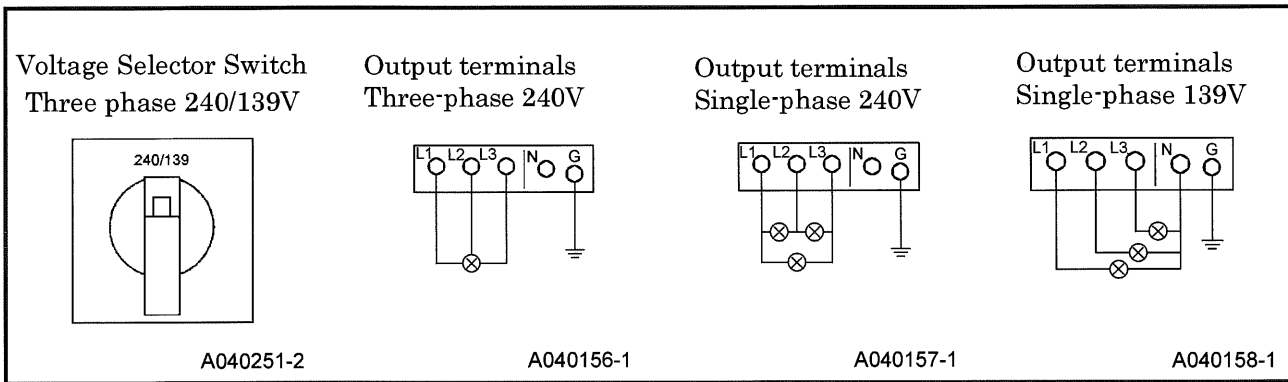
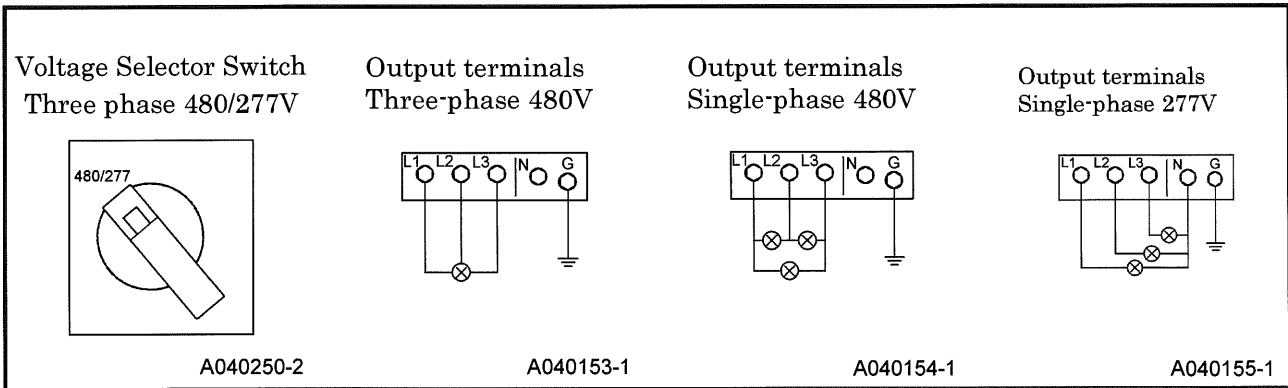

CAUTION

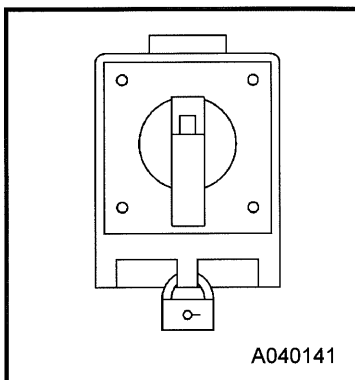

- During operation, do not operate the voltage selector switch. Voltage selection during operation may cause abnormal voltage on the load side to damage the load and may cause a fire.
- In addition, it may cause damage to generator and automatic voltage regulator (AVR).
- Ensure the generator is shut off and the engine has stopped before using the voltage selector switch.
- When voltage selection is completed, lock the voltage selector switch in position to prevent anyone from operating it.

3. Operation

3.2.2 Auxiliary AC Power

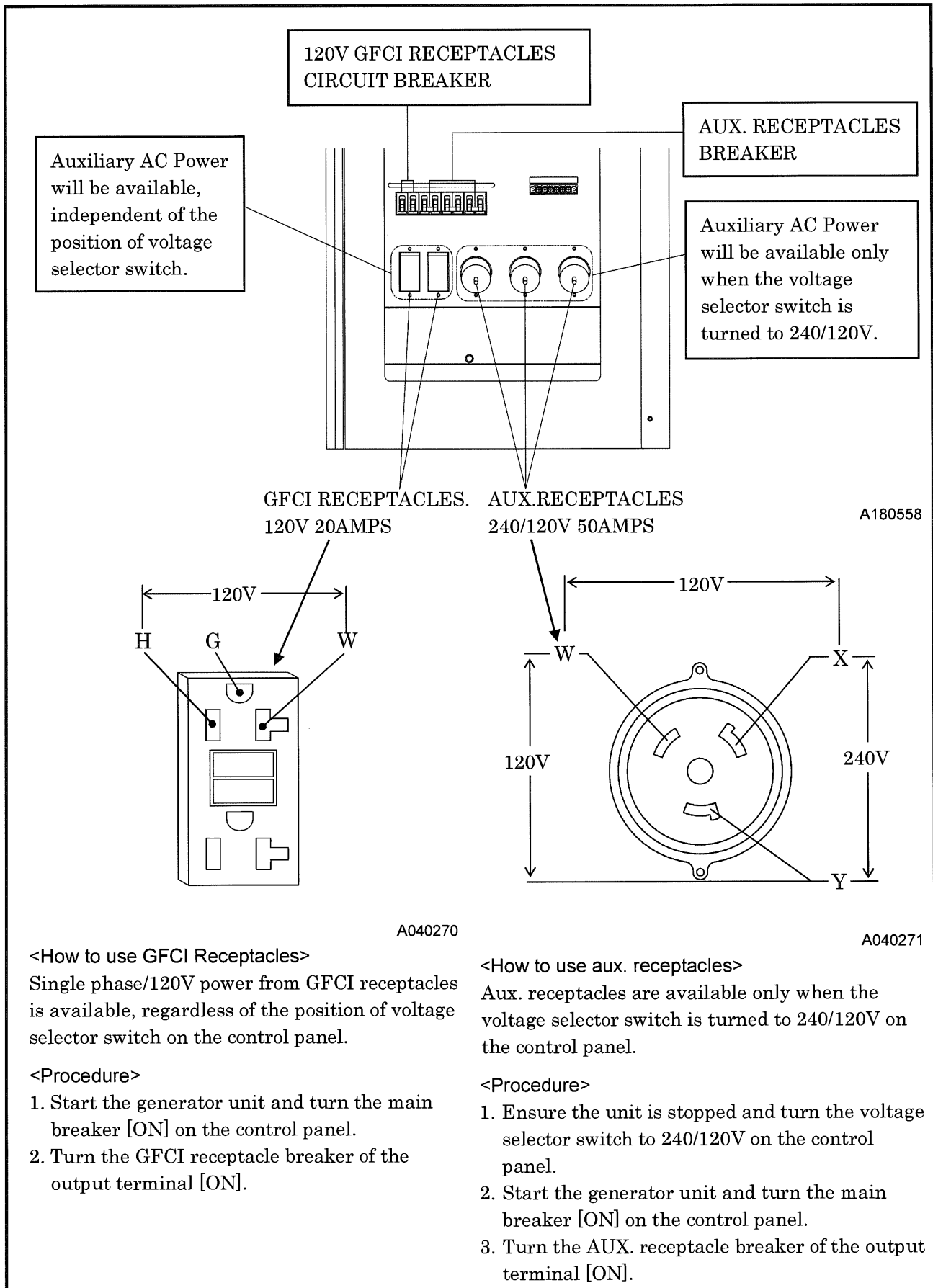

3. Operation

3.2.3 The Maximum Combined Simultaneous Power Consumption

The following chart shows the maximum power available from the 120V-20A GFCI receptacles during simultaneous consumption (main terminals and receptacles) for both single and three phase settings. Values shown in the left column give the maximum current available at the 120V-20A GFCI receptacles for a single receptacle as compared to the value of the simultaneous current consumption from the main terminals.

[Allowable load capacity of GFCI at single phase]

Single Phase (240/120V)	GFCI Receptacle
kW	A
28.3	0
27.1	5
25.9	10
24.7	15
23.5	20

[Allowable load capacity of GFCI at three phase]

Three Phase (240/480V)	GFCI Receptacle
kVA	A
45.0	0
40.8	5
36.7	10
32.5	15
28.4	20

CAUTION

- When the main terminal, single-phase (240/120V) or three-phase (240/480V) is used together with the GFCI outlet (single-phase 120V), the above allowable load capacity of the GFCI outlet must not be exceeded.

3. Operation

3.3 Engine Oil · Coolant · Fuel

3.3.1 Engine Oil

Use engine oil recommended below. Be sure to use CJ-4 class or higher engine oil or superior class. (Using engine oil with poor quality may shorten the life of the engine).

Classification	API service classification CJ-4 class or higher
Viscosity	SAE10W-40 (delivery condition)

IMPORTANT

- Viscosity of engine oil greatly affects starting, performance, and oil consumption of the engine, as well as wear of the moving parts. Choose appropriate oil based upon the table below according to the outside air temperature.

Ambient temperature range and oil viscosity (SAE)

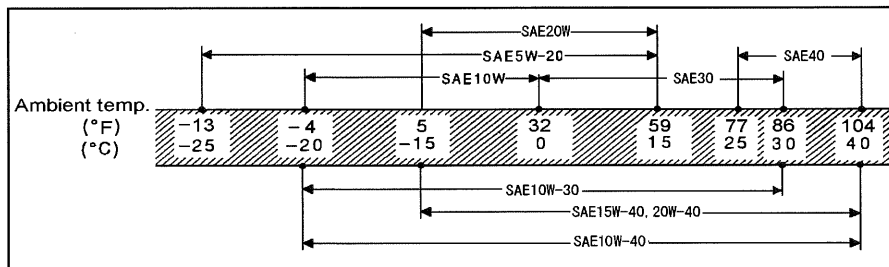

A200331E

- Do not mix oils. If two or more different brands of oil are mixed, its performance can be deteriorated.
- When the machine is operating under a light load (20% or less) for a prolonged period of time, check the viscosity of the engine oil and other fluids, and replace oil early using about half of the regular replacement time as a guide.
- Unit is delivered from the factory, filled with engine oil recommended by the engine manufacturer.
- **Dispose of oil in accordance with local laws and regulations.**

3. Operation

3.3.2 Coolant

Coolant freezing could cause cracks of cylinder and radiator. Be sure to always use mixture of LLC (antifreeze) and soft water (like tap water) of good quality.

IMPORTANT

- When water with dirt, sand, or dust, or hard water such as well water (ground water) is used, deposits can form inside the radiator or on the cylinder head and resulting in engine overheating from poor coolant flow.
- Adjust mixing ratio of coolant according to the temperature. (55% volume coolant is filled when the unit is shipped from factory.) Use coolant within the range of its mixing ratio between 60%. (If LLC (antifreeze) exceeds more than 60%, it may decrease its antifreezing effect.)

Mixing ratio of LLC (antifreeze) (reference)

Outside temperature (°F)	5	-4	-13	-22	-31	-40	-49
Outside temperature (°C)	-15	-20	-25	-30	-35	-40	-45
Mixing ratio (%)	30	35	40	45	50	55	60

- Dispose of LLC (Antifreeze) in accordance with local laws and regulations.

3.3.3 Fuel

IMPORTANT

- Never use fuel with sulfur content greater than 0.0015% (15 ppm).
- Use only ultra-low sulfur fuel.
- Use such diesel fuel which conforms to either EN590 or ASTM D975 standard.
- **Dispose of fuel in accordance with local laws and regulations.**

CAUTION

- Diesel fuel is required to meet the following characteristics:
 - Free from even fine dust particulate
 - Optimum viscosity grade
 - High cetane number (greater than 45)
 - High fluidity even at low temperature
 - Low carbon residue content

3. Operation

3.4 Before Starting the Unit

Before starting the unit, be sure to perform the pre-start inspection. If you find any abnormalities, be sure to repair them before operating the unit. Neglecting inspection or failing to correct any abnormalities prior to starting and operating the unit is a potential fire hazard and may melt internal components.

3.4.1 Check Engine Oil Level

The unit should be level before the checking oil level. When you check oil level after you have started operation, wait more than 10 minutes after stopping the engine before checking the oil level.

<Procedures>

1. Pull out the engine oil level gauge [A] and wipe it with a clean cloth.
2. Re-insert the engine oil level gauge fully and pull it out again. If the gauge shows the oil level between LOW and FULL limits, it is normal.
3. When the oil level is below its LOW, add engine oil from engine oil filler port [B].
 - If the oil is found to be dirty or contaminated, change the oil. (See 5.4.1)
 - To prevent engine output reduction when oil level is too high, do not put more oil in than FULL.

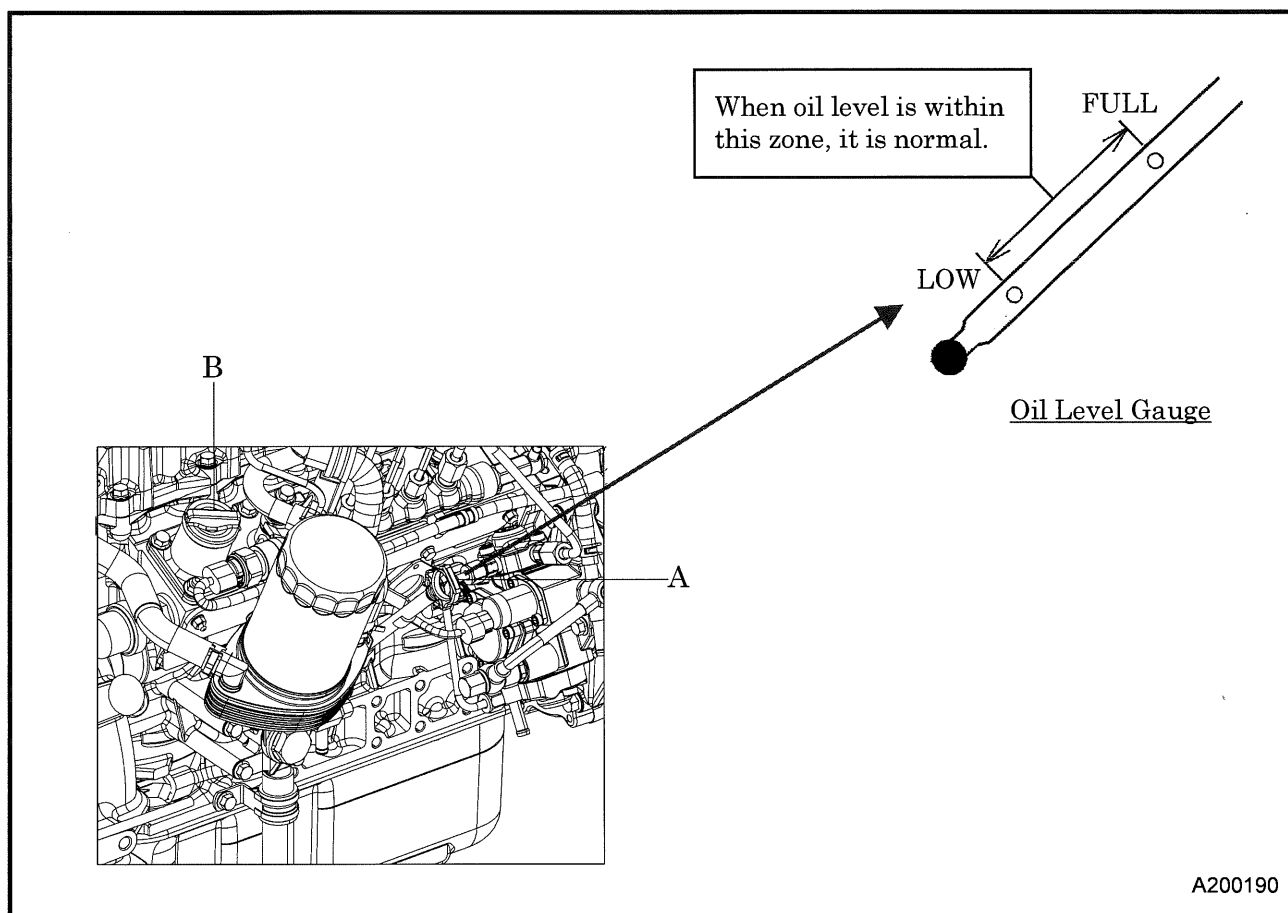

3. Operation

3.4.2 Check Coolant Level

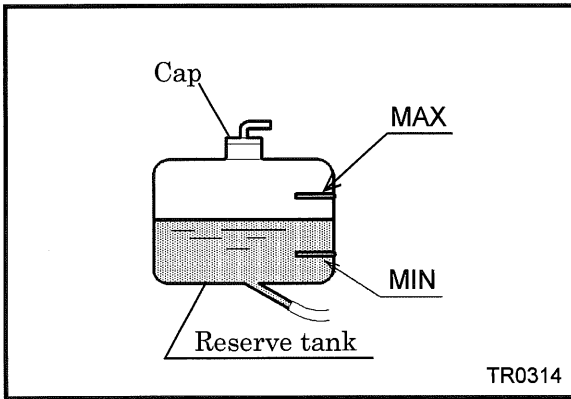

- Verify the coolant level in the reserve tank is above [MIN].
- If the coolant level is lower than "MIN", remove the cap and supply coolant up to the center between "MIN" and "MAX". If too much coolant is poured into the reserve tank, it may overflow during operation.
- If the coolant in the reserve tank is low, remove the radiator cap and check the amount of coolant in the radiator. Refill coolant to the radiator until it reaches just below the radiator coolant filler port. (See 5.4.22)

CAUTION

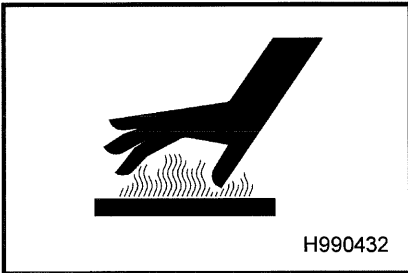

- When removing the radiator cap, lightly turn it and release the internal pressure without completely opening it once the first stage lock is released. After confirming that the internal pressure has been released, turn it off while pushing in until the second stage lock is released. If this procedure is neglected, the inner pressure can blow off the radiator cap, and steam jetting out of the radiator may cause scalding burns.

IMPORTANT

- Do not operate the machine without sufficient coolant. Insufficient coolant can cause air bubbles to form and damage the radiator.

3.4.3 Control Panel Instrumentation Cleaning

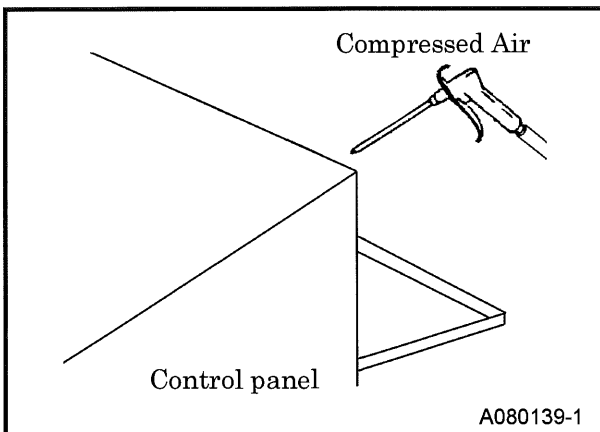

- Before starting operation, open the control panel and check each breaker, terminal plate and all controllers for any dust, sand, or dirt accumulation.
- If the machine is operated with dust, sand, or dirt in the instrumentation, it may cause malfunction or damage. When necessary, clean the inside of the panel with compressed air. Wear protective eyewear when cleaning.

3. Operation

3.4.4 Check Fuel

Prior to operating the unit, ensure there is sufficient fuel remaining to prevent shortage during operation. If necessary, drain condensate accumulated at the bottom of the fuel tank.

- Refueling should be done outdoors or in a well-ventilated place.

- **Do not fill fuel up to the filler level.**

When the fuel tank is filled up to the filler level, the expansion volume of the tank is too small and may lead to problems with fuel flow and containment. Furthermore, fuel may spill from the fuel tank due to vibration caused during movement or transportation of the unit.

※ **When using an external fuel tank, note that the fuel indication on the display will not reflect the actual fuel level.**

CAUTION



- Do not, under any circumstance, bring lit cigarettes and/or matches near fuel.
- The fuel is extremely flammable and dangerous. Be aware of fire sources that can easily ignite the fuel. Refuel only after stopping the engine, and never leave open fuel cans near the machine. Do not spill. It is a fire hazard. When spills occur, wipe up thoroughly. Never use an alcohol-based cleaning fluid. When it adheres to plastic parts, it may cause cracking that will lead to visible degradation of the liquid surface, and worst case the cracks may result in fuel leaks.

3.4.5 Check Fuel Filter Condensate

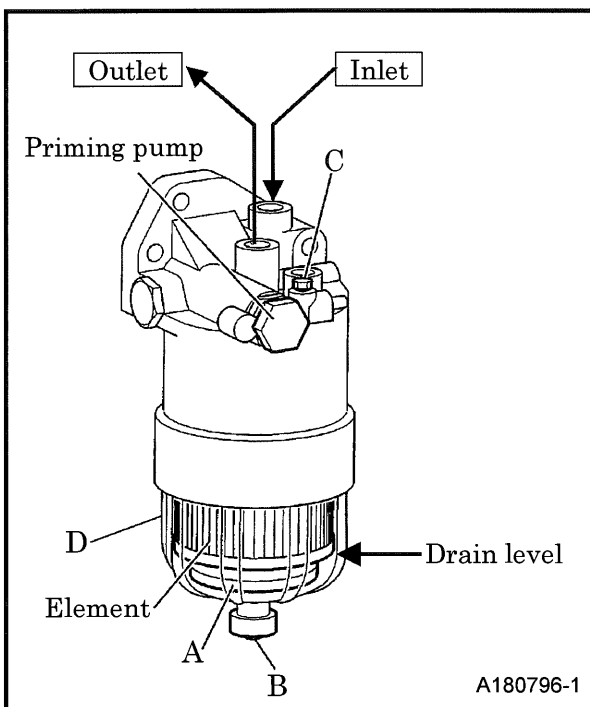

When the red float [A] inside the fuel filter is above the Water drain line, drain condensate from the fuel filter.
<Procedure>

1. When draining condensate, attach a drain hose to drain plug [B].
 2. Prepare a container. Loosen drain plug [B] and air bleeding plug [C] to drain.
 3. After draining is finished, be sure to tighten drain plug [B] and air bleeding plug [C].
- Do not remove fuel filter case [D] as removal may cause fuel spillage. When removal is necessary, plug the inlet hose with a clip prior to removal. Drain the condensate into a container, and then dispose of condensate according to the designated regulations.

3. Operation

3.4.6 Check Interior

Periodically check the inside of the generator for dust and flammables

 **CAUTION**

- Please wear personal protective equipment, such as a helmet, safety glasses, earplugs, safety shoes, gloves, and a mask as appropriate to the work environment.
- Periodically check the inside of the generator for dust and flammables. When any flammables such as chips of wood, dead leaves (dry leaves) and waste paper are left near heated exhaust muffler and heated exhaust pipe, all of them should be removed.
- Keep a fire extinguisher on hand near the machine in case of fire hazards.
- It is advisable to have a list of phone numbers of doctors, ambulance and the fire department available in case of emergency.

3. Operation

3.4.7 Check Belt Tension

Adjust the alternator belt by the following procedure:

Unfasten the mounting bolts and nuts of the alternator to adjust the alternator belt.

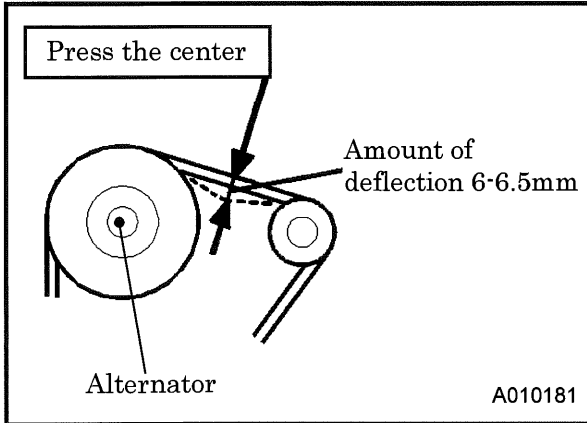

<Procedures>

1. Visually check there are no cracks or wear or other damage to the belt.
 2. Belt tension is adjusted by loosening the alternator mounting bolts and nuts. While pressing the center of the belt slightly, adjust belt tension by loosening fitting bolt so the amount of deflection is between 6 and 6.5mm (98N).
 3. If there is any oil or coolant on the belt, wipe it off completely during service.
- Refer to engine instruction manual for more details for belt adjustment.

WARNING

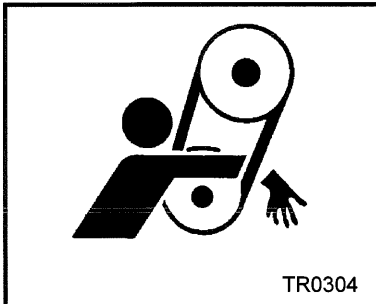

- Be sure to stop the engine whenever the tension of the belt is to be adjusted.
- Remove the negative (-) side cable from the battery.
- If the unit is not stopped, the operator's hand may be caught in the belt and cause serious injury. Be sure to stop the engine whenever performing inspections or maintenance near the cooling fan.
- If the unit is not stopped, the operator's hand may be caught in the fan and cause serious injury.

IMPORTANT

- Over-tensioning of the belt leads to shaft breakage and reduced bearing life. If it is too loose, belt slippage may lead to premature breakage of the belt or damage to the machine due to overheating.

3. Operation

3.4.8 Check Thermo-Label of Stator

Thermo-label on the stator irreversibly changes its color from white to brown when reaching or exceeding 212°F (100°C), that color change signals an overload during operation. If it has discolored, there is a possibility that an abnormality has already occurred in the generator end, immediately reduce the load, and contact your nearest dealer.

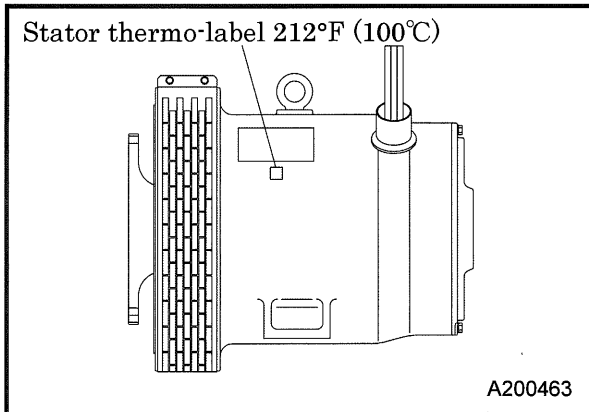

- Use compressed air to remove accumulated debris and dust from inside the generator end.
- If the thermo label has discolored and after all abnormalities have been resolved, replace with a new thermo label.
- For replacement, contact your nearest dealer.

3.4.9 Check Oil Fence Condensate

One oil fence condensate drain port is located on the operation panel side of the machine.

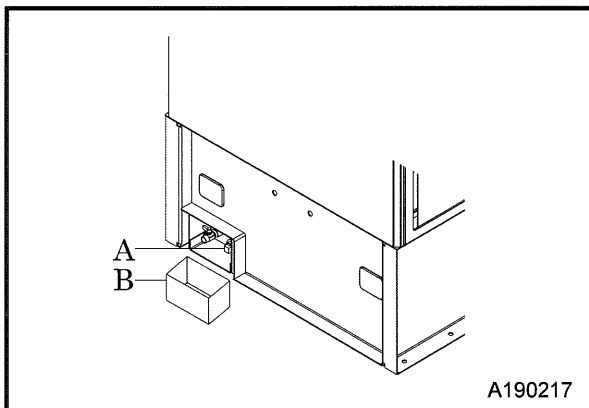

- Remove drain plug [A] from the oil fence drain to drain the condensate.
- Check that all condensate is drained, and then re-install the drain plug.
- Drain the condensate into a container [B], and then dispose of condensate according to the designated regulations.

CAUTION

- If the drain contains fuel, oil, or coolant, inspect each part for leaks.

3.4.10 Check Doors

Pull the handle forward to open the door. When closing the door, be sure that the door is securely latched.

WARNING



- Keep the door closed and locked while running the machine.
- When opening the door unavoidably, be careful not to touch the moving and hot parts. Scalding burns or serious injury may result.

3. Operation

3.5 Operating Procedure

Make sure that all enclosure doors are closed before starting.

3.5.1 Starting and Stopping Procedure

To start, please follow the procedure below.

Manual Mode

<Procedures>

1. Set the circuit breaker [A] on the instrument panel to [OFF] position.
2. Set the selector switch [B] to [ON] position.
3. Push the manual mode button [C].
4. Push the start button [D] to run the engine.

(Preheating is started automatically in cold weather. After the glow lamp [E] turns off, the engine starts.)

5. Once the engine has started, let it warm up for approximately 5 minutes in a no-load condition.

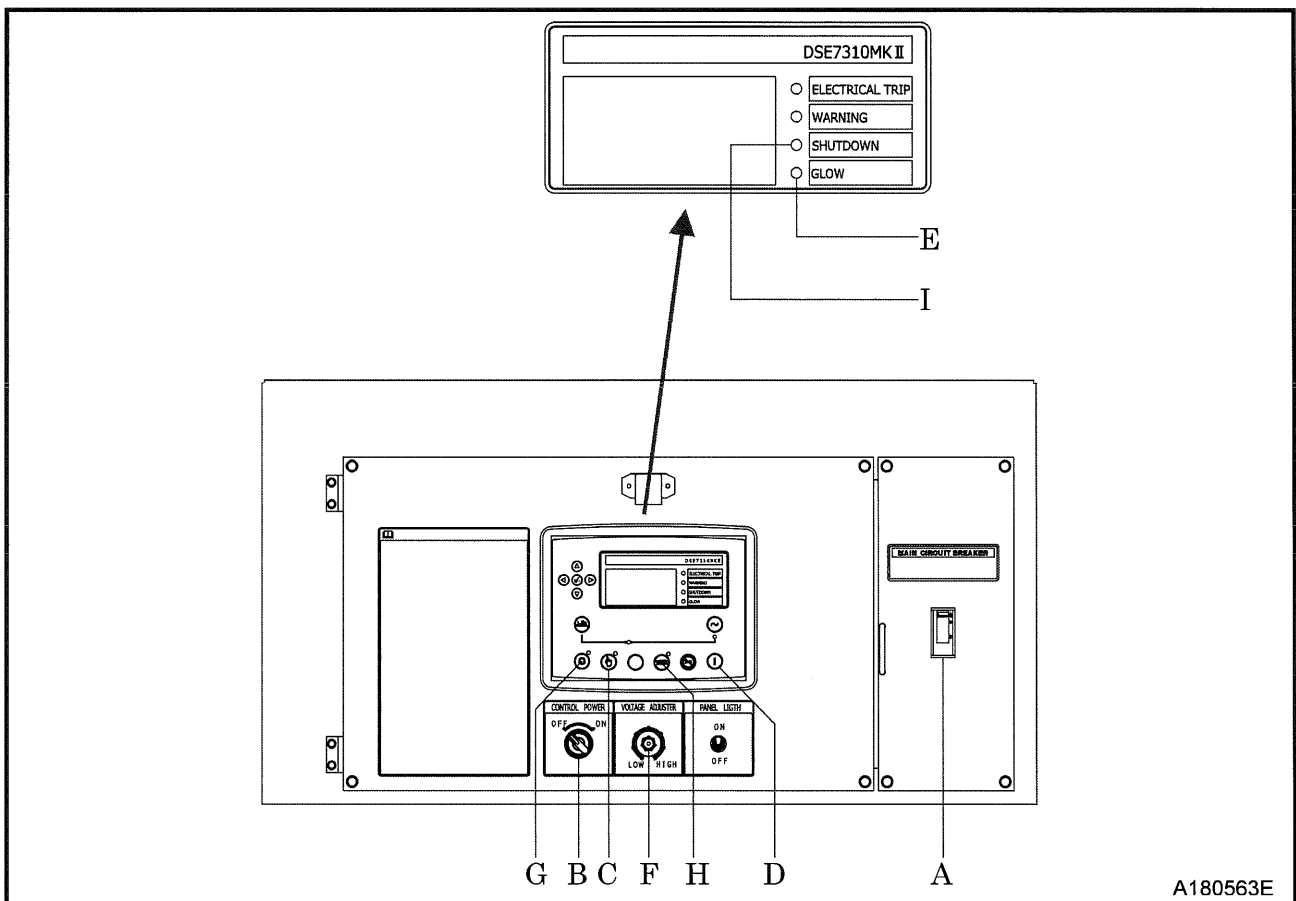

A180563E

WARNING

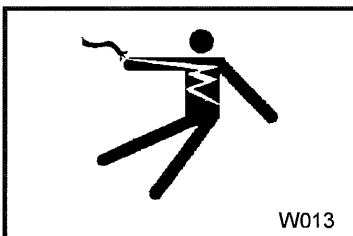

- Keep the output terminal cover shut and locked whenever the machine is running. Note that a voltage of several hundred volts is applied to the output terminal and control board. When opening the output terminal cover is unavoidable, be careful not to touch the output terminal. Electric shock or serious injury may result.

3. Operation

Check frequency and voltage

<Procedure>

1. After warm up, on the **Generator** display screen press ▲▼ to show [Generator Frequency]. Check that the frequency of the generator is at 60Hz after warm up. (See 3-2)

Generator Frequency	
60.0 Hz	

Display Screen

2. Press ▲▼ to show [Generator Voltage] and adjust to rated voltage with the voltage adjuster dial [F].

Generator Voltage	
L1-L2	480V
L2-L3	480V
L3-L1	480V

Display Screen



Voltage Adjuster Dial

Load Operation

<Procedures>

1. Set the circuit breaker [A] to [ON] and supply power to the load.
 - During operation, check and confirm whether the generator functions properly. (See. 3.5.2)
 - ※ Before starting to supply power to the load, make sure that the voltage is in accordance with the load.

IMPORTANT

- After the engine starts up, warm it up unloaded for approx. 5 minutes.
- Warming up after starting up is necessary for smooth operation of the engine. Do not operate the engine at full load immediately after it starts up. This will shorten the equipment life.
- During the warm-up operation, examine the different parts of the equipment for any looseness, leakage of water, oil, fuel, and other irregularities. Also, make sure that the alarm lamps are off.
- Be sure to operate the generator at the rated frequency, irrespective of the load capacity.
If the machine is operated at a frequency lower than the rated frequency, it may cause the generator end to burn.

<Shutdown Procedure>

1. Stop the load.
 2. Set the circuit-breaker [A] to [OFF] position.
 3. After about 5 minutes cooling down operation, push the stop button [G] to stop the engine.
 4. Set the power control switch [B] to [OFF] position.
- ※ The engine controller is on for a few minutes after the engine has stopped. Do not remove the battery cables, etc., during this period.

3. Operation

Auto Mode

1. Cable connection method for a remote control switch.

- Connect the cable to the remote control terminal [A1-A2] of the remote operation terminal block [J] and install the remote operation switch between [A1-A2]. Prior to connecting this cable be sure the (-) battery cable is disconnected. Connect the battery charger to the battery charging terminal [P-N] on the remote operation terminal block [J].

<Procedures>

1. Adjust to rated voltage in manual mode and stop the engine.
2. Push the auto mode button [H].
3. Set the circuit breaker [A] to the [ON] position.

The engine will start when the remote operation switch between the remote control terminal [A1-A2] is set to [ON]. (Preheating is started automatically in cold weather. After the glow lamp [E] turns off, the engine starts.)

4. The engine will stop when the remote operation switch between [A1-A2] is set to OFF.

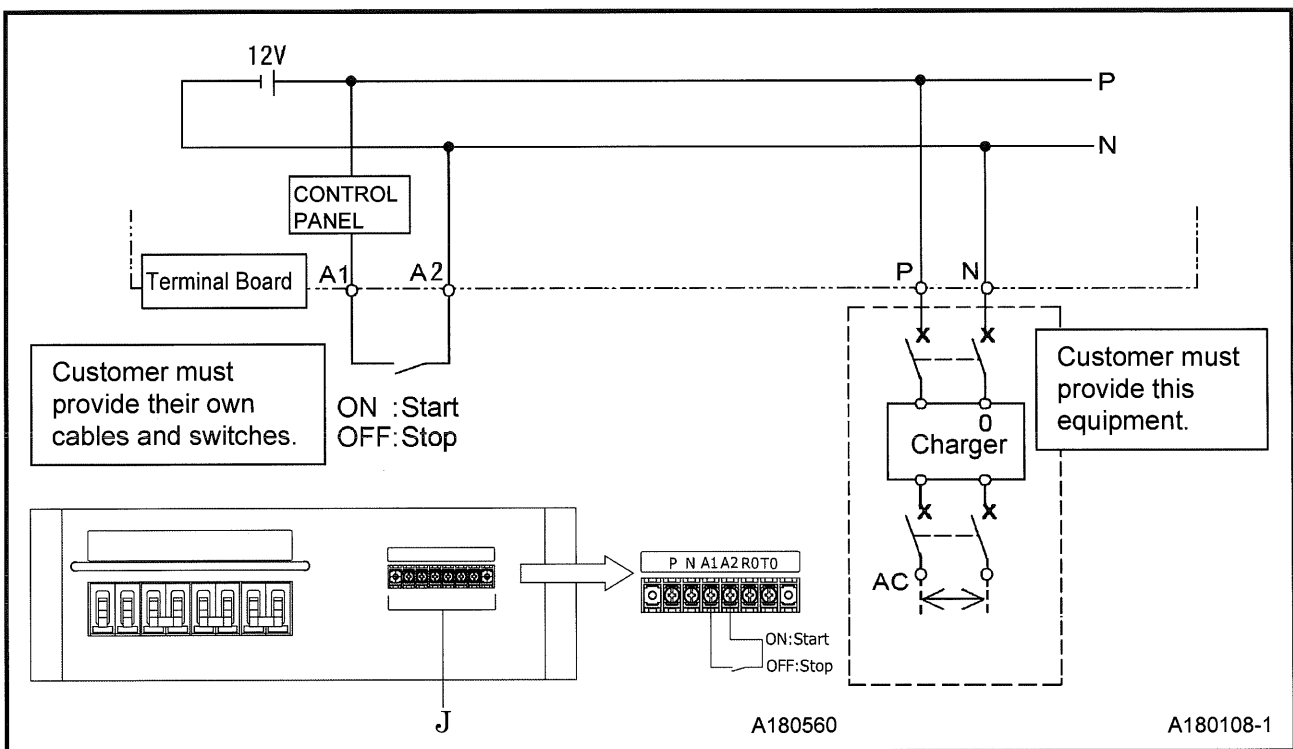

CAUTION

Inspection and maintenance prohibited during auto mode



- Never put your hands near the interior of the unit during Auto Mode, even when the unit is stopped, as the START-STOP signal is still live.
- When performing inspection and maintenance, make sure to hang an "Under inspection and maintenance" tag on the remote switch.
- Disconnect the (-) terminal of the main battery.

IMPORTANT

Install the battery charger

- During Auto Mode standby operation, battery discharge will occur. Use a battery charger to ensure charging of the battery.

3. Operation

2. Function

- When the start signal activates in stand-by mode, it starts the unit. (This includes preheating.)
When the stop signal activates, the unit will continue to operate for 10 seconds to cool down, then the unit stops and is placed again in stand-by mode.

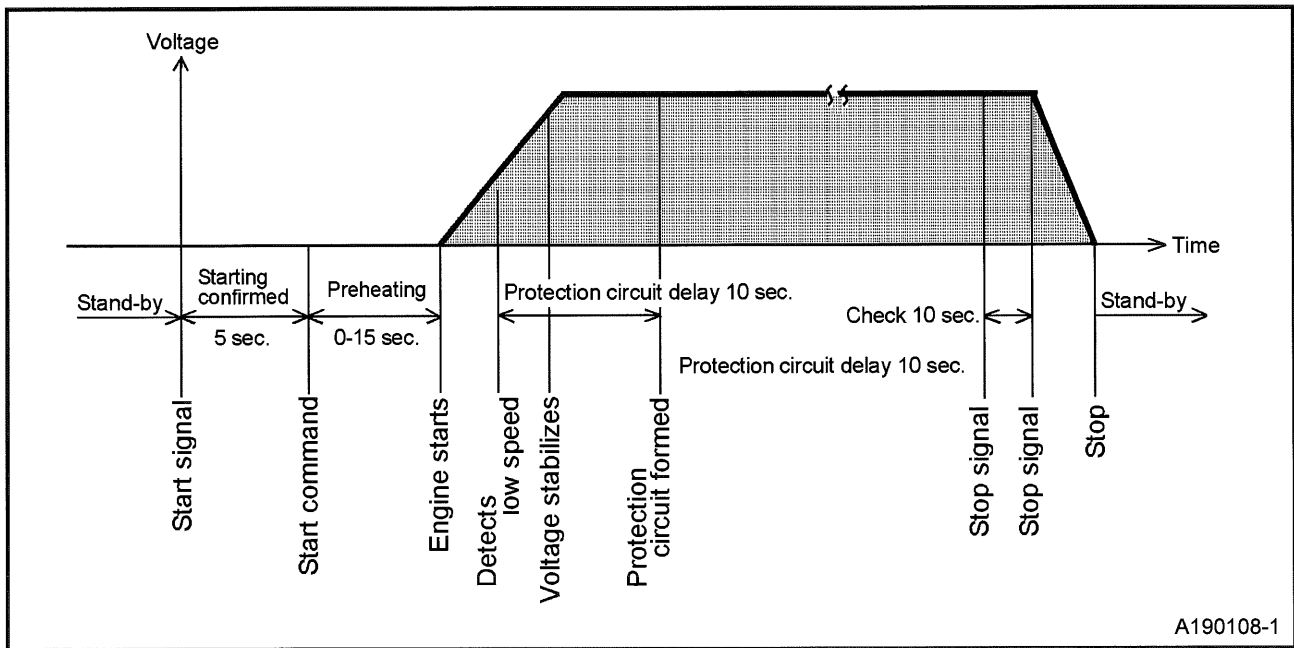

3. Starting Action

- If the engine will not start after cranking for 10 seconds, stop it for 8 seconds before trying again. If the engine will not start even after cranking is repeated three times, the SHUTDOWN lamp [I] will illuminate due to Fail to Start error.
- If the engine will not start and the SHUTDOWN lamp is illuminated, troubleshoot the cause of engine failure before proceeding.

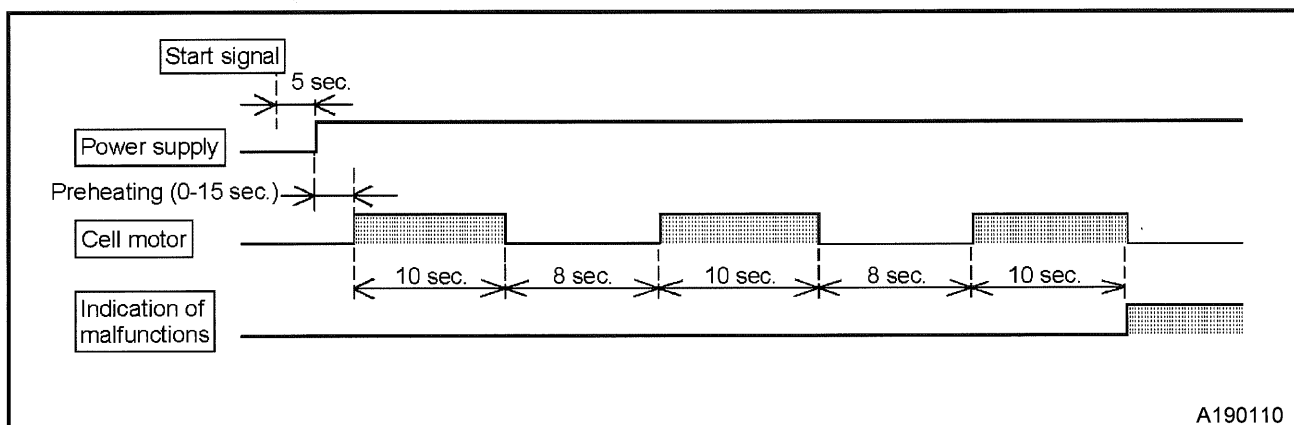

IMPORTANT Perform periodic inspection and maintenance of the generator

- To check performance, run the unit for 5 to 10 minutes once a week.

3. Operation

3.5.2 Meters and indicator lights during operation

During normal operation, each indication of instruments is shown in the table below. Refer to the table for daily checks.

Note: The values marked * vary with location of the voltage selector switch.

		Voltmeter (V)	Frequency meter (Hz)	Ammeter (A)	Monitor Lamps			
					ELECTRICAL TRIP	WARNING	SHUTDOWN	GLOW
Before Start	CONTROL POWER switch (ON)	0	0	0	● OFF	● OFF	● OFF	● OFF
	During Operation (Max load)	* 240 480	60	Less than rated current	● OFF			

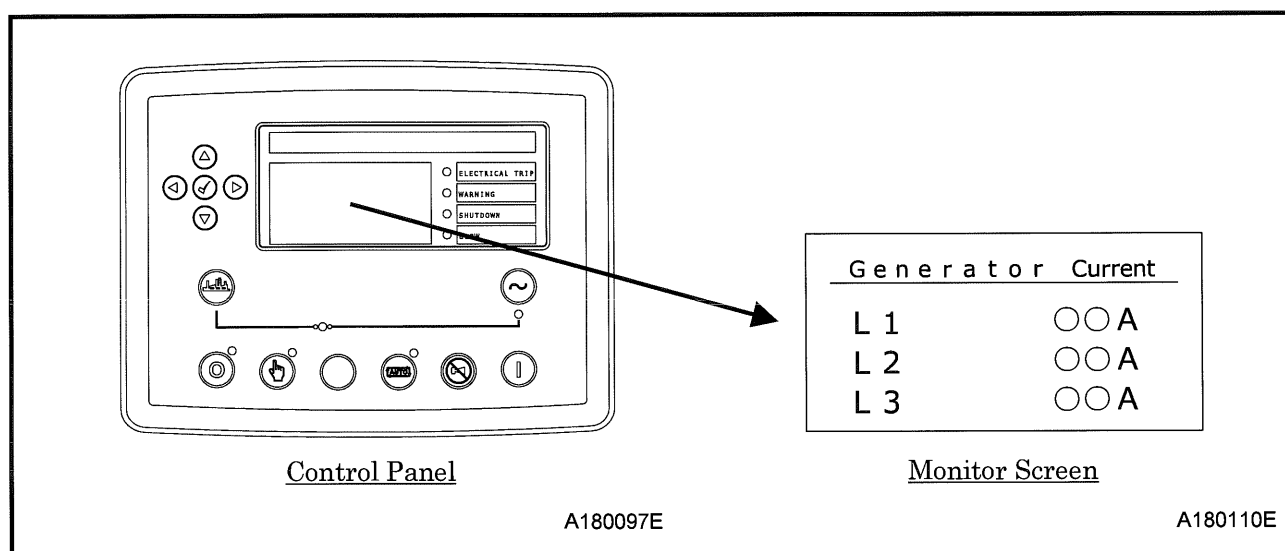

- Be sure to frequently check meters and indicators for proper operation, or any machine water, oil, fuel leaks, etc.
- The above table gives standard values. They may vary slightly depending on operating conditions and other factors.
- In single-phase load operation, navigate to the Generator screen, press to switch to the [Generator Current] screen, and check the current flowing in each phase (L1, L2, L3) on the screen. Each current should be balanced if unbalanced. Change load connections so the current of L1, L2, and L3 is equally balanced. Make sure that the current of each phase does not exceed the rated one.

※ Keeping a record of machine operation and service checks in the Operation Log will help with discovering any underlying issues or problems with the machine before they become severe.

3. Operation

CAUTION



- Do not under any circumstance, open the valves below during operation.
- Coolant condensate drain valve
- Engine oil condensate drain valve

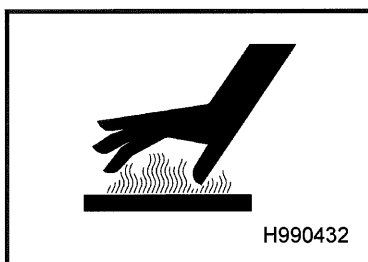

- Never work nearby hot portions of the machine while it is running.
- Do not touch hot portions of the machine while inspecting during operation.
- Specifically, parts such as the engine, exhaust manifold, exhaust pipe, muffler, radiator, and intercooler are extremely hot. Never touch these parts, it will cause scalding burns.
- Coolant water and engine oil are also very hot and dangerous to touch. Avoid checking or refilling them while the machine is running.

- If the circuit breaker repeatedly trips during operation, reduce the load.
- When running a single phase load, check the current of each phase and try to keep the load of each phase consistently average.
- If you continue to operate the generator while ignoring or neglecting these cautions, it could cause overheating and result in fire. Furthermore, should operation continue at a lower level than the standard rated frequency, it could burn the generator and any motors of the attached load.

3.5.3 Operation Panel light

- The panel is equipped with an LED light. Turn the panel light switch [ON] to use.
- When illumination is not necessary, turn the light [OFF]. If the machine is always operated with the lamp switched [ON], the lamp life will be reduced.

3.5.4 Operating procedures when engine fails to start up on first attempt

If the engine repeatedly fails to start, the following causes are suspected. Check the following:

- No fuel
- Clogging of the fuel filter
- Battery discharge (Low cranking speed)

3. Operation

3.5.5 Fuel line air bleeding device

If the machine runs out of fuel, bleed the air, according to the following procedures.

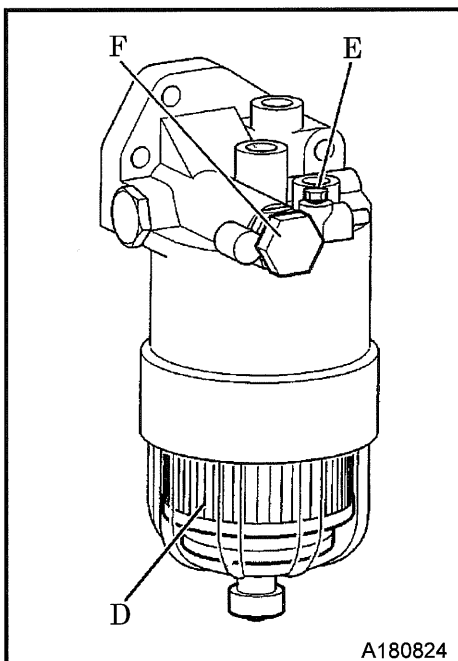
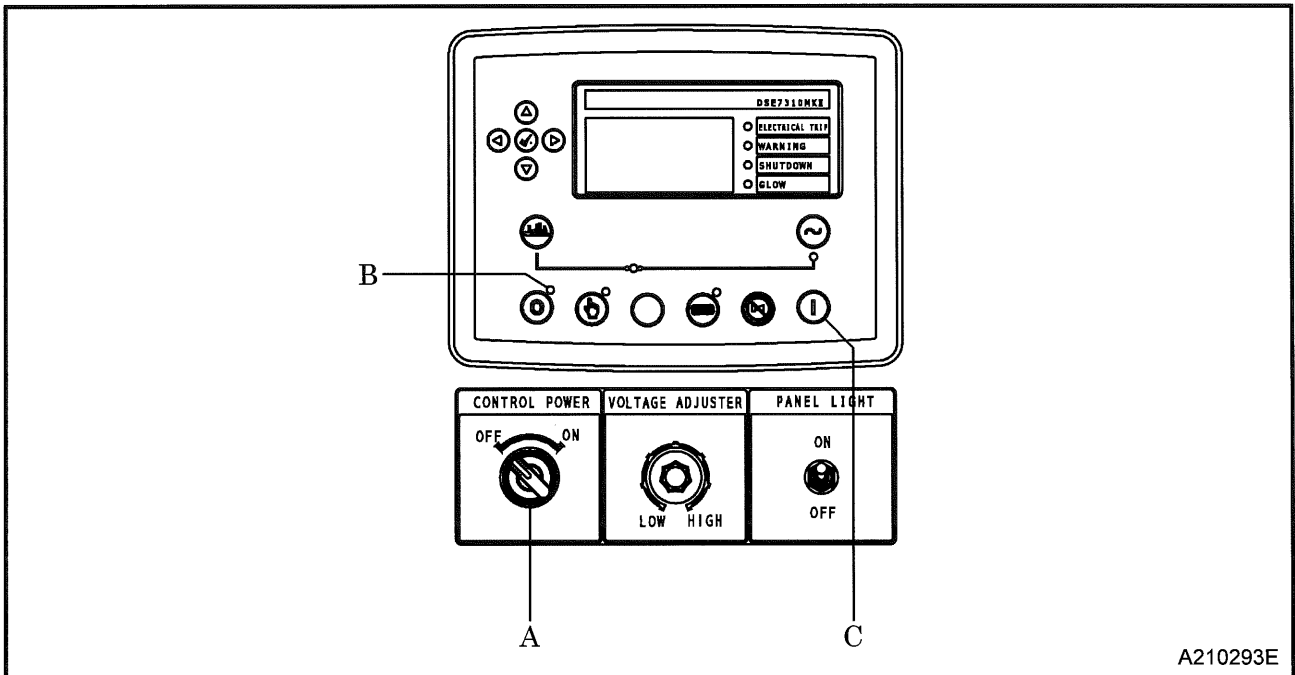

<Procedure>

1. Refill the fuel.
 2. Set the control power switch [A] to [ON] position.
 3. When the stop mode indicator lamp [B] is lit, press the start button [C] to turn on the electromagnetic pump.
 4. Loosen the air bleeding plug [E] of the fuel filter element [D] and loosen the priming pump [F], push the priming pump back and forth until fuel comes out (more than 20 times).
 5. After air bleeding is completed, tighten the air bleeding plug and push the priming pump back and forth until the fuel filter element is filled with fuel (more than 10 times).
 6. Wait about 1 minute, and then loosen the air bleeding plug to bleed air from the fuel filter element.
 7. Repeat steps 4 to 6 until the air does not come out of the air bleeding plug.
 8. Finally, firmly tighten the air bleeding plug and priming pump to wipe the surrounding fuel clean.
- Air bleeding plug tightening torque: 10.0N·m
- For details, refer to the engine operation manual.

CAUTION

- Tighten the air bleeding plug firmly to the specified torque. Loosening of the air bleeding plug may cause fuel leakage.

3.5.6 How to check engine information

By pressing the start button [C] when the stop mode indicator lamp [B] is lit, the key can be turned ON without starting the engine, and the water temperature, ECU current DTCs, etc. can be checked. After 2 minutes, the system will automatically return to the key OFF state.

3. Operation

3.6 Emergency Stop

3.6.1 Emergency stopping procedures

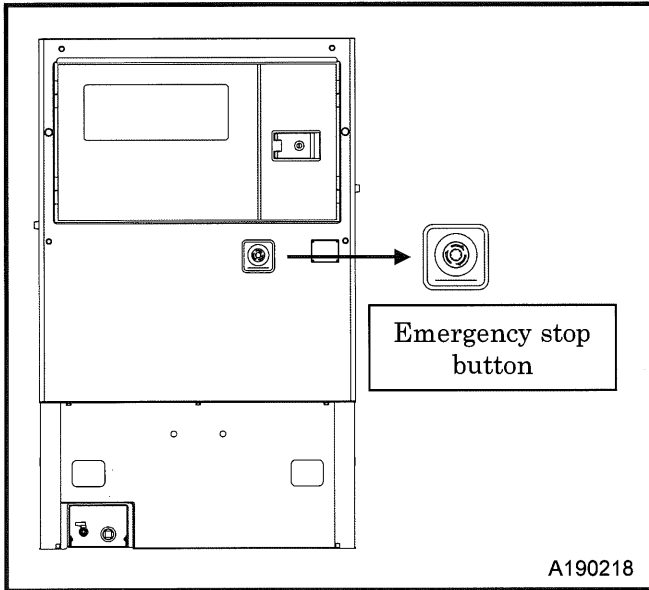

- If it is necessary to stop the generator for an emergency, press the Emergency Stop button located below the control panel. When pressing the emergency stop button, the machine will stop immediately.

3.6.2 Resetting the emergency stop button

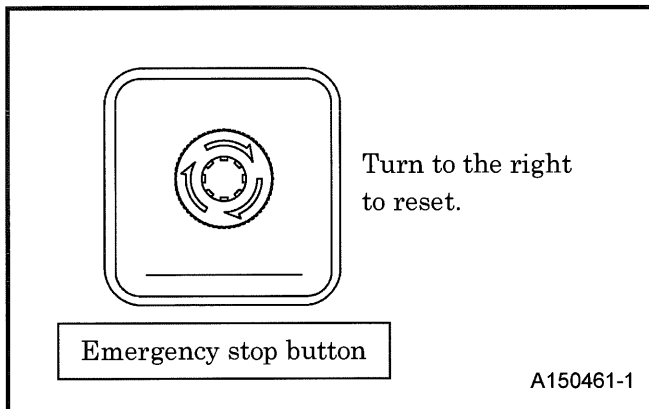

- After emergency stopping, be sure to carry out an investigation of the problem which caused you to use the emergency stop and take appropriate countermeasures. Release emergency stop button only after resolving the problem that required an emergency stop. To reset the button, turn the button head in the direction of the arrow.

※ If it is not reset, the machine cannot restart.

4. Failures and Troubleshooting

4.1 Protection devices

To prevent issues during operation, this machine is equipped with various protection devices.

4.1.1 List of protective devices, warning lamps, and monitor alarms

This machine is equipped with protective devices and indicates the type of issue with lamps and messages on the monitor display as shown in the table below. Shown below are the typical items. When the Warning lamp is activated or any other monitor alarm is displayed due to other engine trouble, contact your nearest dealer.

Item	Control Panel					Function
	Monitor Lamp			Display Screen		
	ELECTRICAL TRIP	WARNING	ENGINE SHUTDOWN	Alarms	ECU Current DTCs	
Low Engine Oil Pressure	☀️ ON	-	☀️ ON	ECU Red	ENG Oil Press. Low	Warning: lower than 14PSI (0.098MPa)
High Coolant Temp	☀️ ON	-	☀️ ON	ECU Red	Water Temp High	Engine Shutdown: above 212°F (100°C)
Overspeed	☀️ ON	-	☀️ ON	ECU Red	Engine Speed High	Engine Shutdown: above 2070 RPM
Clogged Air Filter	-	☀️ ON	-	Air Filter	-	The lamp illuminates when the air filter is clogged and requires cleaning or replacement.
Oil Fence liquid level rising	-	☀️ ON	-	Containment Level	-	When more than 10.5gal (40L) of condensate (fuel, oil, coolant) accumulates the lamp will light
*Low Fuel Level	-	☀️ ON	-	Low Fuel	-	When remaining fuel tank capacity is less than 5% the lamp will light
Over Current/ Short Circuit	☀️ ON	-	☀️ ON	Over Current	-	Occurs during overload and short conditions
High Voltage	☀️ ON	-	☀️ ON	Over Voltage	-	Engine Shutdown at voltage above 108%
Other Engine Trouble	**	**	**	**	**	**

*Not functional when using an external fuel tank.

**Please contact your nearest dealer.

When ECU Red or ECU Amber is displayed, press button once to change screen to ECU current DTCs and check screen.

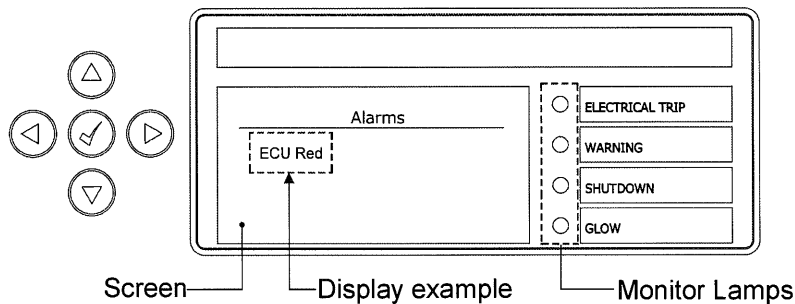

A180100E

CAUTION

- If the protective device operates and the engine stops or the circuit breaker trips, refer to the cause of the failure and take countermeasures to remedy the issue and then restart operation.

4. Failures and Troubleshooting

4.1.2 Circuit Breaker

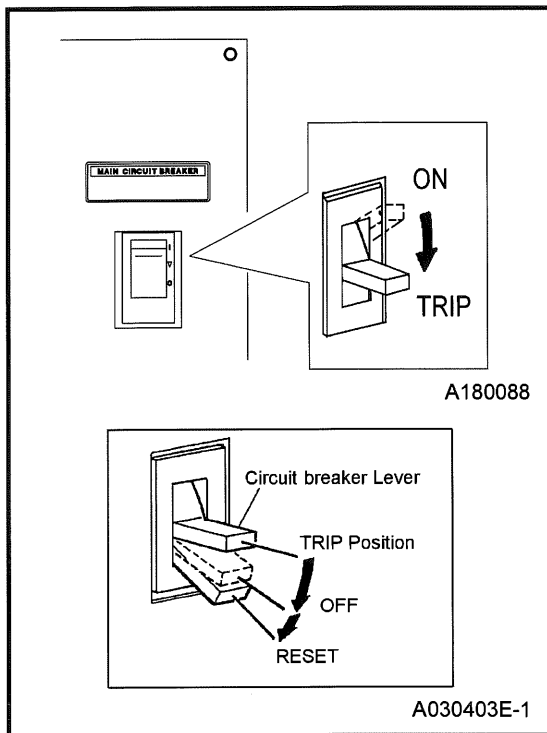

- In case of an overload or short-circuited wire connection, the circuit-breaker trips.
- When the breaker is tripped, stop the machine immediately and reset the circuit breaker after resolving the cause of the trouble.

<How to reset>

- To reset the lever of circuit breaker, press the lever downward firmly until the lever “clicks” into place.

4.1.3 Circuit protector (CP) for AVR protection

AVR is equipped with a circuit-protector (CP) for protection against over current. It will activate under the following conditions:

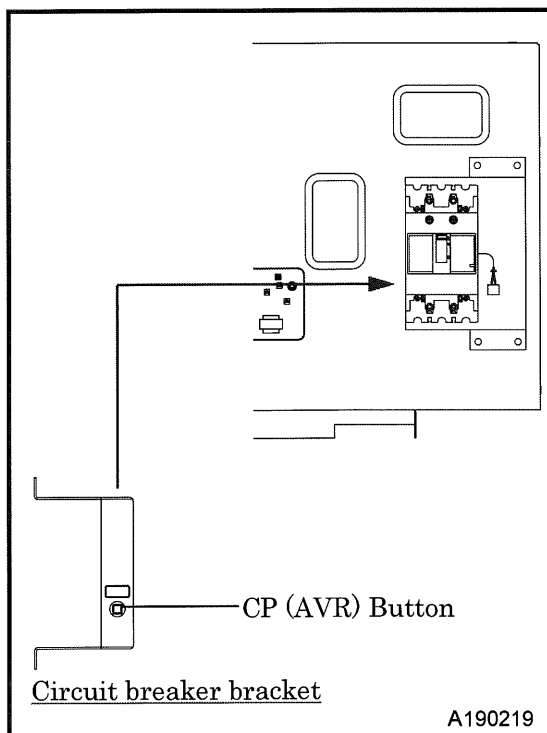

- When an excessive load is applied while the engine RPM is low.
- When the output voltage of machine is increased above the specified voltage.

<Symptoms>

- When the CP activates, following effects occur.
 - (1) The voltage will not reach rated voltage.
 - (2) The voltage is usable, but voltage fluctuation is great and voltage restoration under load is slower.

<How to reset>

- Lightly press the CP (AVR) button on the side of the circuit breaker bracket inside the control panel.

4. Failures and Troubleshooting

4.2 Troubleshooting

Should any trouble occur during operation, do not leave it. Investigate the cause and take appropriate measures. Read the manual carefully and fully understand what to do in case of trouble.

- The better you understand the construction and function of the machine, the faster you can find the problem and solution.
- This chapter describes the state, cause, and countermeasures of important troubles in detail:

Symptom	Cause	Countermeasures
Starter does not rotate. Low starter RPM when starting.	(1) Battery malfunction (2) Charging malfunction (3) Alternator malfunction (4) Starter malfunction	Check Battery →Charge/Change Change Change
Starter rotates normally but engine does not start up.	(1) No diesel fuel (2) Air in fuel lines (3) Clogged fuel filter (4) Clogged nozzle (5) Controller malfunction	Refuel Bleed air Disassemble/Clean and Change Disassemble and clean Check fuse Check connectors Check controllers
※ “Engine Oil Pressure Low” is displayed on the screen.	(1) Engine oil shortage (2) Clogged engine oil filter (3) Loosened or disconnected wiring or connectors (4) Oil pressure switch malfunction	Replenish engine oil Change Check/tighten Change
※ “Water Temperature High” is displayed the screen.	(1) Coolant shortage (2) Belt slippage (3) Clogged radiator (4) Faulty thermostat (5) Looseness, disconnection of wiring or connectors (6) Faulty coolant temperature switch	Replenish coolant Adjust tension Clean Change Check/tightening Change
※ “Air Filter” is displayed on the screen.	(1) Clogged air filter element	Clean or replace filter element
※ “Containment Level” is displayed on the screen.	(1) Condensate accumulated in the oil fence. (2) Oil fence liquid surface level sensor is not functioning.	Drain the condensate Check/Change

※ Refer to section 4.1.1 for monitor lamp and display screen details.

4. Failures and Troubleshooting

Symptom	Cause	Counter measures
Circuit breaker trips.	(1) Overloaded (2) Load side short-circuit.	Reduce the load Get rid of cause of short-circuiting.
No voltage or too low voltage generated when operated at rated frequency.	(1) Terminal connections are loose (2) Broken or shorted to the exciter field winding (3) Faulty exciter (4) CP (circuit protector) for AVR protection activated (5) Faulty AVR (6) Broken or short-circuited winding of generator end (7) Faulty silicon rectifier (mounted on generator end rotor) (8) Faulty control panel	Check/tightening Repair Repair Reset Change Repair Change Change
Too high voltage generated when set at the rated frequency (50Hz/60Hz), Voltage will not drop even when the voltage regulator control dial is turned.	(1) Loosened or disconnected wiring, or connector to the AVR (2) Broken wire or poor contact of AVR variable resistor (3) Faulty AVR	Check/tightening Repair or change Change
Unstable voltage generation	(1) Poor tightening of each terminal (2) Function circuit protector (CP) for AVR protection (3) Faulty AVR	Check/tightening Reset Change

- Contact your nearest dealer if you find it difficult to repair by yourself.
- For details on engine troubleshooting not listed on these pages please refer to the engine operation manual.

5. Periodic Inspection

5.1 Important Items at Periodic Inspection and Maintenance

This manual shows the inspection and maintenance intervals under normal operating conditions, not the warranty period. When using under severe environmental conditions or operating conditions, shorten the maintenance interval.

- Be sure to use appropriate tools for inspection and maintenance work. Inappropriate tools could cause unexpected injury.
- Please wear personal protective equipment such as a helmet, safety glasses, earplugs, safety shoes, gloves, and a mask as appropriate to the work environment
- Take care not to touch hot portions of the machine while inspecting during operation. Parts such as the engine, exhaust manifold, exhaust pipe, exhaust muffler, radiator, intercooler, generator, and pipes are especially hot, so never touch those parts, because it may cause scalding burns.

WARNING

Hang an "Under Maintenance" tag

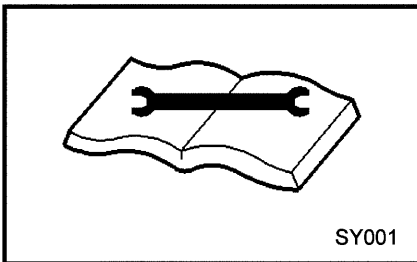

- Before starting inspection, set the machine's circuit breaker to OFF, and then attach the "Under Inspection" label to an easy-to-see location.
- Remove the negative (-) side cable from the battery. If the above procedure is neglected, and another person starts operating the machine during check or maintenance, it could cause serious injury.

IMPORTANT

Uninstructed/unspecified work prohibited

- Be sure to use recommended fuel, DEF, oil, grease, or LLC (antifreeze).
- Do not disassemble or adjust engine, generator or part(s) for which inspection or maintenance is not referred to in this manual.
- Use genuine parts for replacement.
- Any breakdown, caused by using unapproved parts or by wrong handling, will be out of the scope of "WARRANTY".
- Do not pour water or steam on electrical components.
- Place a container or a pan underneath the oil port to catch waste liquid so that such liquid does not spill on the floor or inside the machine.
- Be sure that no waste liquid is disposed of on the ground. Such waste on the ground, river or lake will cause serious environmental contamination. Be sure to follow the local regulations. If harmful material such as oil, antifreeze solution or filters are disposed of incorrectly, the responsible person can be punished by the appropriate authorities.
- Observe local regulations when disposing of such toxic materials as oil, fuel, LLC (antifreeze), filters, and battery etc.

5. Periodic Inspection

5.2 Periodic Inspection and Maintenance Schedule

Items marked with a ○ are to be performed by the customer. For the following items or clauses marked with a ●, contact your nearest dealer because they require expert technical knowledge to perform.

The following table shows the intervals of inspection and maintenance under normal operation conditions. Inspection and maintenance should be done at either the hour or the period mentioned in the remarks column, whichever comes earlier.

(This table is a guide only, it does not represent the warranty period. Please change maintenance interval according to usage load and environmental conditions.)

(Unit : Hour)

Maintenance Items		Daily	Every 250 hours	Every 500 hours	Every 1,000 hours	Ref. Page	Remarks
Generator	Control panel instrumentation cleaning	○				3-10	Clean as required.
	Check thermo-label of stator	○				3-13	
	Check control panel	○				3-18	
	Check GFCI receptacles		○			5-8	Every month
	Check insulation resistance		○			5-9	Every 2 months
	Check thermo-label on the bearing		○			5-10	Every 2 months
Engine related	Check engine oil level	○				3-9	
	Check coolant level	○				3-10	
	Check fuel	○				3-11	
	Check fuel filter condensate	○				3-11	
	Check belt tension	○				3-12	If too loose replace
	Change engine oil		○			5-4	
	Change engine oil filter element			○		5-5	
	Check battery electrolyte		○			5-5	
	Check and clean air filter elements		○			5-7	
	Check carbon accumulations in exhaust system		○			5-8	
	Drain fuel tank		○			5-10	
	Check specific gravity of battery electrolyte.			○		5-5	
	Change fuel filter element			○		5-10	
	Clean exterior of the radiator and intercooler			○		5-11	Clean as required.
	Drain intercooler condensate			○		5-11	
	Clean fuel air bleeding pump filter			○		5-11	
	Check and cleaning of the supply pump strainer			○		5-12	
	Check flexible exhaust pipe			○		5-13	Every 4 months
	Change air filter elements				○	5-13	
	Change coolant (LLC)				○ (Every 2 years)	5-15	
Clean fuel tank interior				●			
Others	Check interior	○				3-12	
	Check oil fence condensate	○				3-13	
	Check terminals and wirings			○		5-12	Every 4 months
	Check gen end anti-vibration rubber				○	5-14	Once a year
	Check each rubber hose				○	5-14	Once a year
	Clean the oil fence and check for rust				●	5-14	Once a year

The above intervals of inspection and maintenance are respectively based on the operation time of 125 hours of used per month and of 1,500 hours of use per year.

5. Periodic Inspection

Maintenance		Every 1,000 hours	Every 1,500 hours	Every 3,000 hours	Remarks
Engine body	Check engine valve clearance	●			Please contact nearby distributor or engine distributor for inspection and maintenance.
	Clean EGR cooler		●		
	Check and clean EGR valve			●	
	Check and clean injector			●	

5.3 Periodic Replacement Parts

Part numbers change upon modification. For replacement of parts, contact your nearest dealer to verify the part number is correct or applicable.

Part Description	Part Number	Q'ty
Air Filter Element	32143 11700	1
Engine Oil Filter Element	ISUZU 898075-6761	1
Fuel Filter Element	ISUZU 898143-0411	1
Gasket Kit for Fuel Air Bleeding Electric Pump	ISUZU 898071-4040	1 kit
Strainer [A] for Engine Supply Pump	ISUZU 898074-9550	1
Strainer [B] for Engine Supply Pump	ISUZU 109630-0830	3
Strainer [C] for Engine Supply Pump	ISUZU 109630-0850	3
Belt	ISUZU 898095-3350	1

5. Periodic Inspection

5.4 Maintenance Items

5.4.1 Change Engine Oil

Every 250 Hours

When checking, replenishing, and draining the engine oil, be sure to wait more than 10 minutes after engine stops to allow it to cool down.

<Procedures>

1. Remove the engine oil filler port cap [A], remove the drain plug [B] located outside, and then open the drain valve [C] located inside to drain oil.
 2. After draining is completed, close the drain valve [C] and install the drain plug [B] remove the engine oil filler port cap [A], refill new engine oil. [Oil capacity: approximately 10.4L]
 3. After replenishing the oil, firmly tighten engine oil filler port cap.
 4. Make sure to check engine oil level with the engine oil level gauge before starting the unit.
 5. After replenishing the oil, firmly tighten the engine oil filler port cap [A].
- Drain the condensate into a container [D], and then dispose of condensate according to the designated regulations.

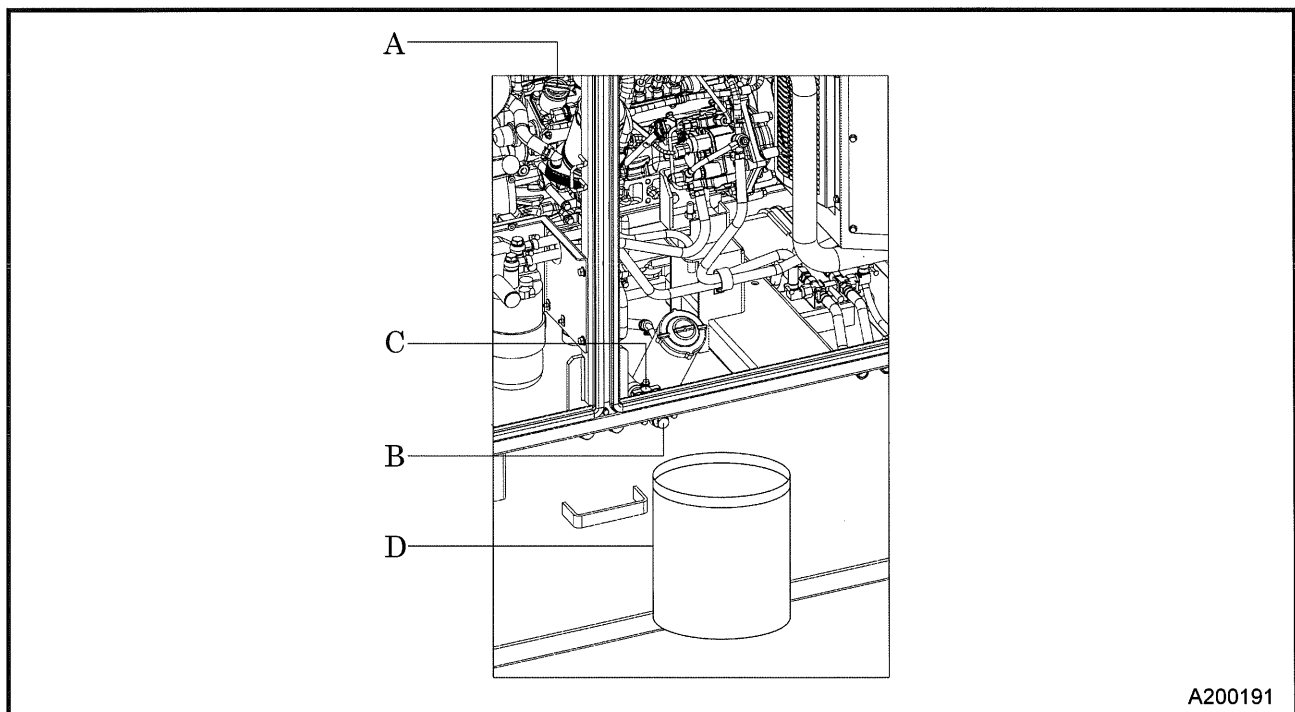

CAUTION

Caution in filling or draining engine oil

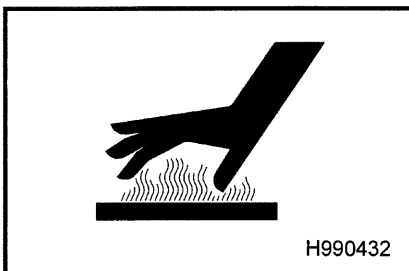

- Engine oil is very hot and highly pressurized during and just after operating. Hot oil may spray out and cause injury.
- Never overfill the engine oil above the proper level. Too much oil can cause white smoke out of the exhaust, and it can damage and harm the engine.

5. Periodic Inspection

5.4.2 Change Engine Oil Filter Element

Every 500 Hours

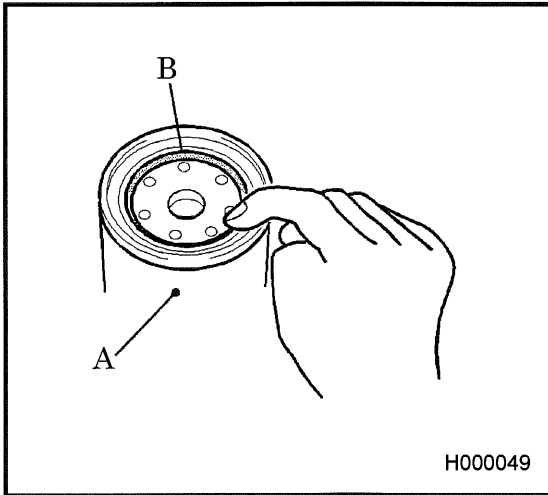

<Procedures>

1. Take out the oil filter element [A] using a filter wrench.
2. After coating fuel on the new oil filter element seal [B], screw it in. After the gasket touches the sealing face, tighten another 2/3 turn with a filter wrench.
3. After installing the oil filter element [A], check for any leaks during operation. (For part number, See 5.3)

5.4.3 Check Battery

Battery electrolyte : every 250 hours

Specific gravity of battery electrolyte : every 500 hours

If there is an engine starting issue due to battery discharge, follow the procedure below:

● Ordinary type battery:

Check the amount of battery fluid and if it is not within specification, add distilled water. Measure the specific gravity of the battery electrolyte, and if it shows below 1.24, recharge the battery immediately. (See 5.4.4)

● Enclosed type battery:

Check the indicator on top of the battery.

If the indicator shows that charge is needed, recharge the battery immediately.

If specific gravity of battery electrolyte does not rise despite replenishing with distilled water or charging the battery, replace the battery immediately.

5. Periodic Inspection

5.4.4 Maintenance of Battery

Battery may generate hydrogen gas and can explode. Therefore, recharging should be done in a well-ventilated place.

- Do not check the battery by short-circuiting the positive and negative terminals with a piece of metal.
- Never operate the machine nor charge the batteries with low battery liquid. Continuing operation at this lower level will cause deterioration of some parts, reduction of battery life, and also it may cause explosions. Add distilled water so that the liquid level is between the "UPPER LEVEL" and "LOWER LEVEL" if the level is too low.
- Wear protective gloves and safety glasses when handling the battery.
- If battery electrolytes contact your clothes or skin, wash it away with a large amount of water immediately.

If the battery electrolytes get into your eyes, flush them immediately with plenty of water and see a doctor at once. Severe damage to eyes and vision may result.

WARNING

Handling the Battery



- Keep open flames away from battery.
- Keep sparks, matches, cigarettes, and other fire sources away from the battery.
- Do not charge a frozen battery as it may explode. If the battery is frozen, warm it up until the battery temperature becomes 61°F to 86°F (16°C to 30°C), and then recharge.
- Battery electrolyte is diluted sulfuric acid. In case of mishandling, it could cause skin burning.
- Dispose of battery observing local regulations.

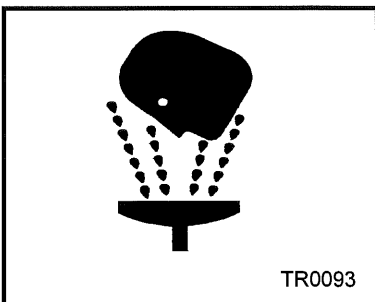
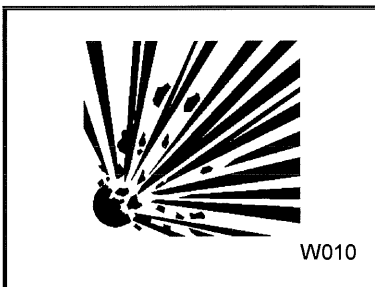

[Charge battery]

- Use the battery charger after you confirm whether it is in good operating condition and ready for use.
- Disconnect the cable between battery and the machine and charge the battery with a 12V battery charger.
- Be sure not to connect (+) and (-) terminals backwards.

5. Periodic Inspection

[How to use booster cable]

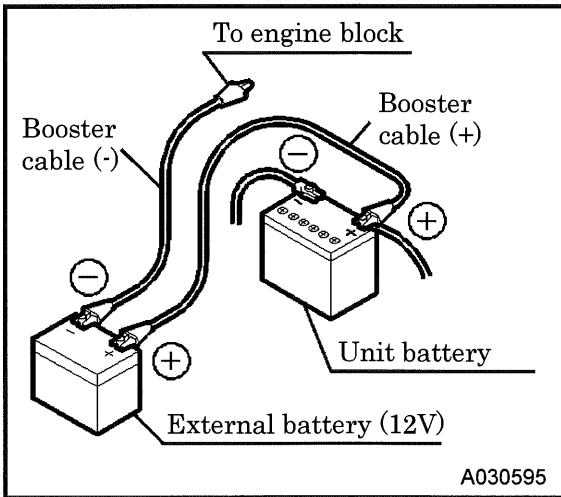

<Procedure>

1. Stop the engine.
2. Connect one end of the (+) booster cable to the (+) terminal of the machine battery.
3. Connect the other end of the (+) booster cable to the (+) terminal of the external battery.
4. Connect one end of the (-) booster cable to the (-) terminal of the external battery.
5. Connect the other end of the (-) booster cable to the engine block of the machine.
6. Start up the engine.
7. Disconnect the booster cable by following the procedure back in the reverse order.

CAUTION

- When a booster cable has to be used or when cables are connected again after a battery is replaced, be careful not to connect (+) and (-) terminals backwards. A backwards connection will cause sparking and damage to components.

5.4.5 Check and Clean Air Filter Elements

Every 250 hours

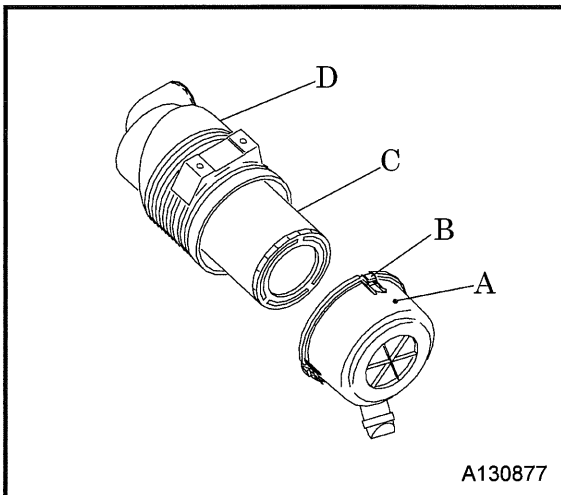

Clean the air filter when [Air filter] is displayed on the screen.

<Procedures>

1. After removing the cap [A] by loosening its cap fixing latch [B], clean its interior properly.
 2. Remove the outer element [C] and clean it.
 3. When installing the cap after finishing the cleaning job, push the element into the case [D] firmly by hand, and then make sure that the cap fixing latches attach securely to the case. Lastly, tighten the latches.
- If the element is found heavily dusty, replace it with a new one. (For part number, See 5.3)

IMPORTANT

- When an element that is clogged or has holes or cracks is used, dust or foreign material will get in the engine. This causes accelerated wear in moving parts within the engine. Be sure to perform daily checks and appropriate cleaning so that the life of the engine will not be shortened.

5. Periodic Inspection

5.4.6 Check Carbon Accumulations in Exhaust System

Every 250 hours

When a diesel engine driven generator is continuously operated with less than 30% load or no load for a long time, carbon will be stuck inside the exhaust pipes, exhaust muffler, and engine body. Unburned fuel may also come out from connected portions of exhaust pipe and outlet port of the exhaust muffler. If it is continuously operated under the conditions, the fuel which comes out could ignite and cause a fire.

Further, wet-stacking and carbon accumulation could cause power drop in the engine as well as overheating, resulting a serious damage to the engine. If this occurs, eliminate the carbon accumulation by burning it under full load operation (to increase exhaust heat) until the exhaust gas becomes almost clear.

(For load current, refer to the following table as a standard value.)

Frequency	Hz	60	
Rated voltage	V	240	480
Load current	A	86	43

CAUTION

- When loading, increase load factor step by step while checking the conditions of the exhaust. Do not place flammables near the exhaust pipe, as sparks may cause a fire.

5.4.7 Check GFCI Receptacles

Once a month or 250 Hours

Periodically, check the GFCI operation for safety.

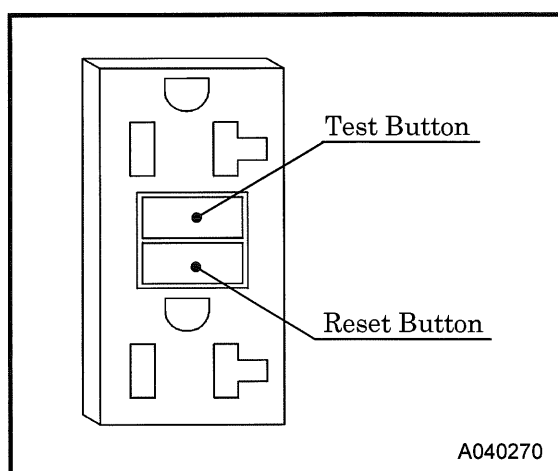

<Procedures>

1. Unplug all appliances from the generator.
2. Start the engine.
3. Turn [ON] the breaker on the operation panel of this machine.
4. Press the test button.
5. Press the reset button.
 - The reset button should extend with a click.
 - If the reset button does not extend, contact your nearest dealer.
6. When the reset button extends during operation.
 - Unplug all appliances from the GFCI protected receptacles.
 - Press the reset button:

If the GFCI cannot be reset: The GFCI is faulty. Contact your nearest dealer.

If the GFCI resets properly: Check the appliance or the power cord.

DANGER

- If the generator is stored outdoors, unprotected from the weather, test the GFCI receptacle before each use.
- When the GFCI trips investigate the cause and correct it.

5. Periodic Inspection

5.4.8 Check Insulation Resistance

Every 2 months or 250 Hours

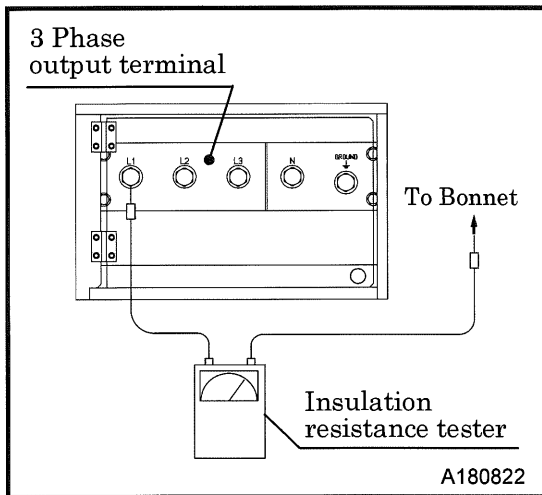

<Procedure>

1. Detach the load side cable from the output terminal board.
2. Loosen and remove the bolt (M6) securing the ground cable between [N] and [GROUND] on the output terminal board.
3. Disconnect the AVR connector [A] inside the generator control panel.
4. Disconnect the connector [B] on the back of the control panel.
5. Switch [ON] circuit breaker [C], and measure insulation resistance between each of the L1, L2, L3 terminals and the bonnet.
6. If insulation resistance value measured is greater than $1M\Omega$, it is good.
7. After checking the insulation resistance, reinstall the ground cable between [N] and [GROUND], AVR connector [A], and connector [B] on the back of the control panel.

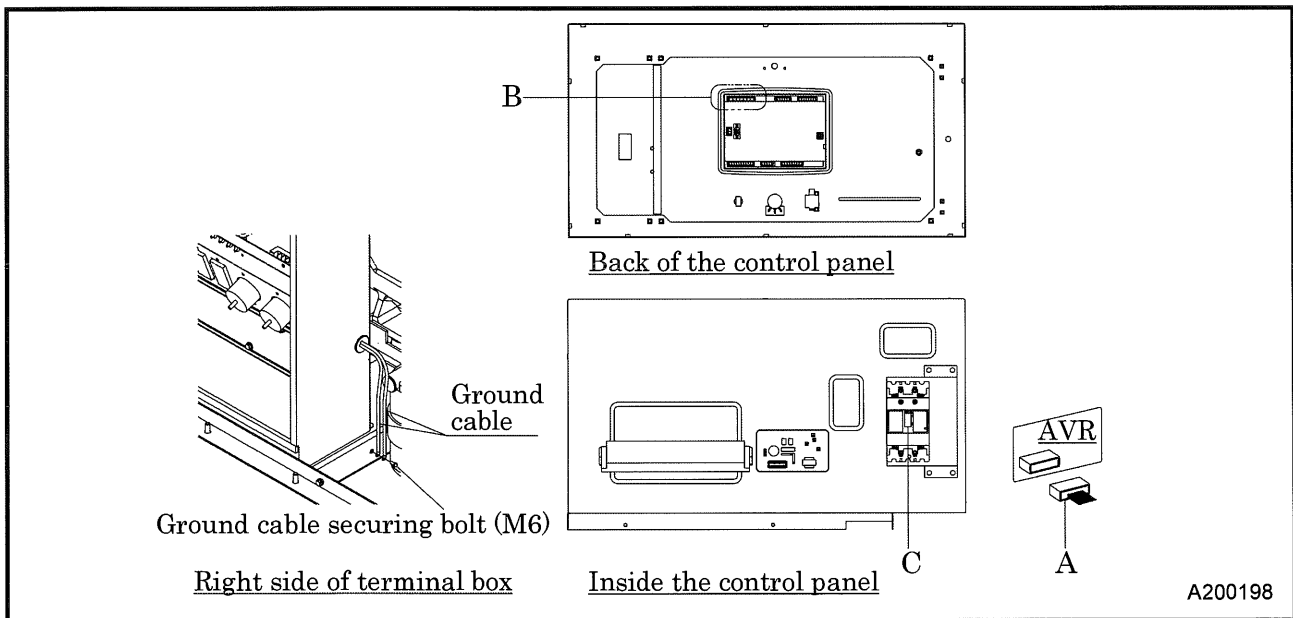

IMPORTANT

- Insulation resistance should be regularly checked or measured with a 500V insulation resistance meter. If it is reduced to lower than $1M\Omega$, it could cause an electrical leakage or a fire.
- For recovery or improvement of insulation resistance, wipe and clean dust and dirt around output terminals, circuit breaker, generator body outlet port and receptacle and dry them. If the above measures do not resolve the problem, please contact your nearest dealer.

⚠ DANGER

- After making sure that the insulation resistance of the generator is higher than $1M\Omega$, be sure to re-connect the cable between the terminal [N] and terminal [GROUND] just as it was originally connected. If it is left disconnected, the grounding becomes incomplete and can cause electric shock.

5. Periodic Inspection

5.4.9 Check Bearing Thermo Label on the Generator

Every 2 months or 250 Hours

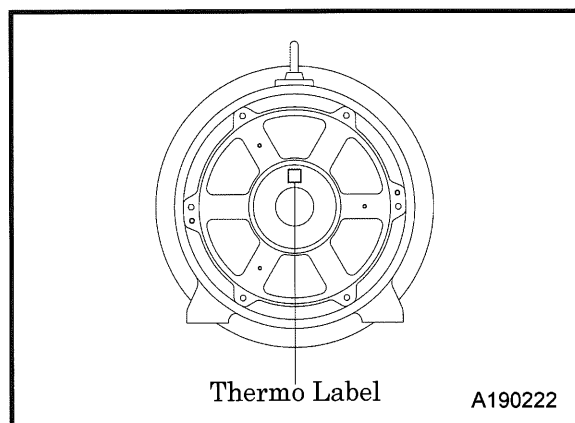

Thermo-label on the rotor bearing irreversibly changes its color from white to blue by reaching or exceeding 176°F (80°C). If discoloration has occurred, check the bearing for abnormal noise or vibration, and contact the dealer immediately.

- Replace discolored thermo-label after making certain that the issue is resolved.
- When replacing, contact your nearest dealer.

5.4.10 Drain Fuel Tank Condensate

Every 250 hours

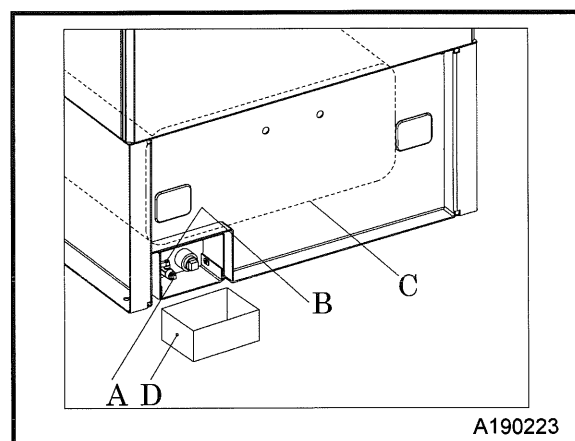

- To drain fuel tank condensate, remove drain plug [A], and open drain valve [B] to drain the condensate accumulated in fuel tank [C].
- After making sure that all condensate is completely drained out, close drain valve [B] firmly and install drain plug [A].
- Drain oil into an appropriate container [D] and dispose of it accordingly to local rules and regulations.

5.4.11 Change Fuel Filter Element

Every 500 hours

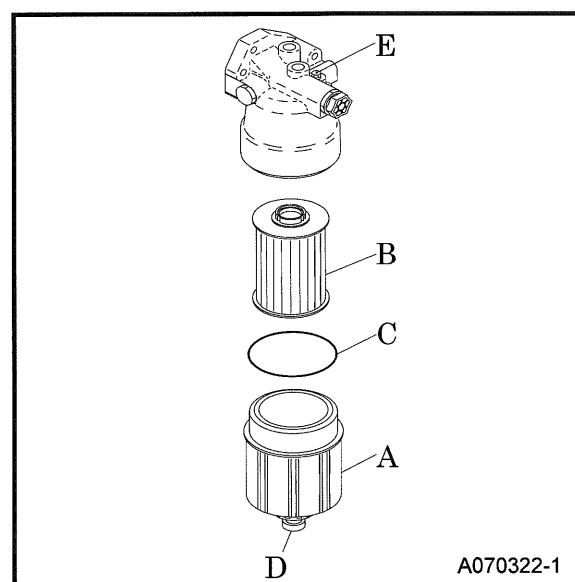

<Procedures>

1. Loosen the drain plug [D] and air bleeding plug [E] to drain the fuel inside the filter. After draining is finished, tighten the drain plug [D] and air bleeding plug [E] securely.
 2. Use the special filter wrench to remove the filter case [A].
 3. Lightly apply fuel to the O-ring [C] of the new element [B] in the case, and screw in the element. (For part number, See 5.3)
 4. After the O-ring touches the sealing face, tighten with a filter wrench.
 5. Bleed air from the fuel lines. (See 3.5.5)
- After installing the element, check it for any leaks during operation.
 - Refer to the engine instruction manual for more details.

5. Periodic Inspection

5.4.12 Clean Outside of Radiator and Intercooler

Every 500 hours

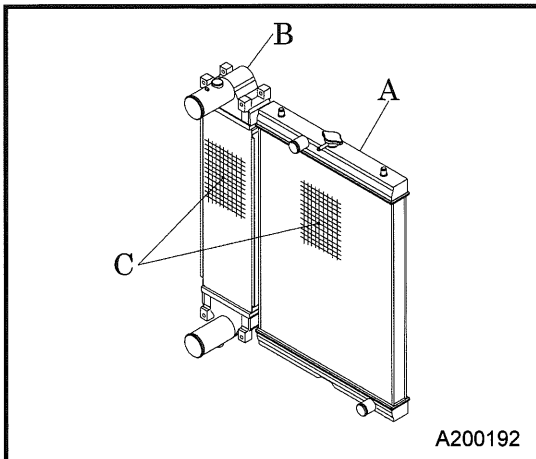

- If the fins and tubes [C] of the radiator [A] and intercooler [B] are clogged with dust and dirt, the heat exchange rate will decrease and the temperature of the coolant will rise, regardless of inspection and maintenance schedule. Clean it according to its clogged condition.
- Do not use a high pressure washer for cleaning as it may damage the fin tubes.
- When the unit is used near the ocean or similar salty environment, clean using fresh water more than once a month.

5.4.13 Drain Intercooler Condensate

Every 500 hours

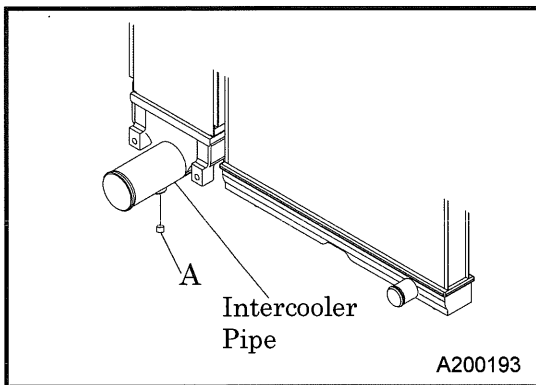

- Remove the drain plug [A] at the bottom of the intercooler pipe and drain the condensate.
- After drainage is complete, attach the drain plug [A].
- Drain oil into an appropriate container and dispose of it accordingly to local rules and regulations.

5.4.14 Clean Fuel Air Bleeding Pump Filter

Every 500 hours

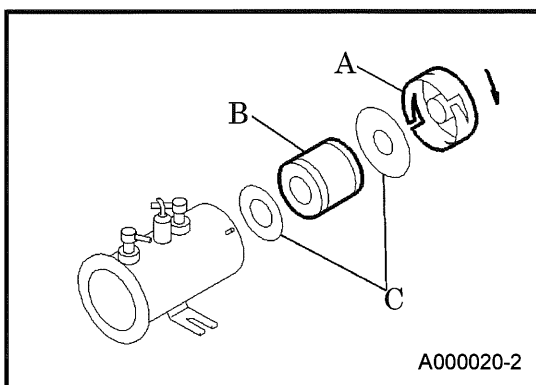

- Turn the cap [A] counterclockwise to remove and clean the internal filter [B] (steel mesh type).
- When removing the filter [B], be sure to replace gasket [C]. (For part number, See 5.3)
- When disassembling, the fuel inside may spill out, so prepare a fuel pan in advance.

5. Periodic Inspection

5.4.15 Check and Cleaning of the Supply Pump Strainer

Every 500 hours

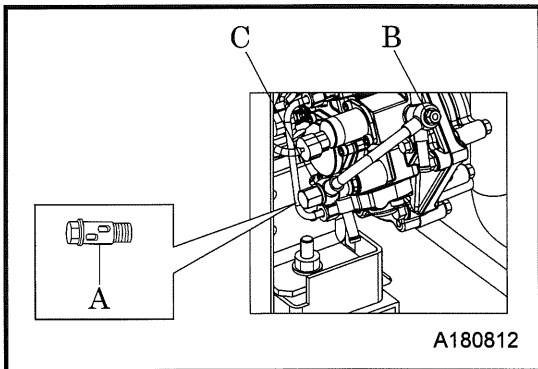

- Loosen the supply pump strainer [A] (joint bolt integrated type) and remove it. After washing it with diesel oil, blow dust and dirt off with compressed air. Replace the gaskets [B] and [C] as well. (For part number, See 5.3)
- If cleaning the supply pump strainer (joint bolt integrated type) [A] does not improve the engine output or remedy the issue, please replace it. (For part number, See 5.3)

- The supply pump strainer cannot be disassembled, do not pull out the internal strainer. (For more information, please refer to the engine instruction manual)

5.4.16 Check Terminal and Wirings

Every 4 months or 500 Hours

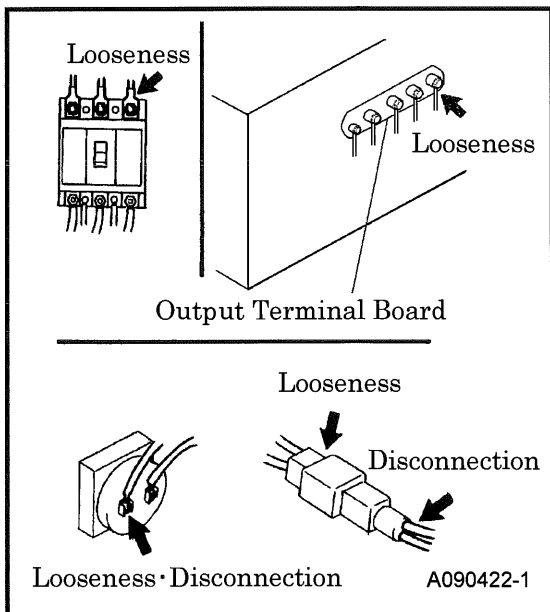

Check for any looseness on the cables, any damage on insulated covers, and disconnection, disconnected cables, or short-circuits etc.

[Inspection points for the electric circuits on the generator side]

- Terminal connections of the 3-phase output terminal plate.
- Main circuit of circuit breaker.
- Terminal connections inside the control panel.
- Each terminal connection of each instrument.

[Inspection points for the electric circuits on the engine side]

- Engine wiring connectors.
- Check for looseness of terminal connections.
- Rubbing or wear of the wires.

5. Periodic Inspection

5.4.17 Check Flexible Exhaust Pipe

Every 4 months or 500 Hours

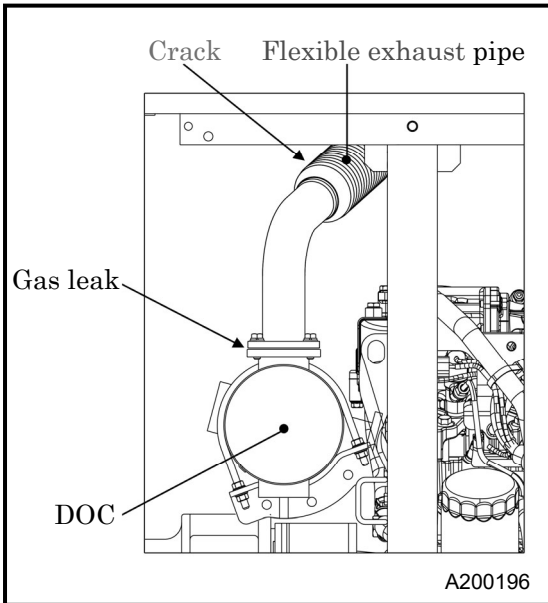

- Check the engine exhaust outlet coupler to flexible pipe for leaks and check for any cracks in the flexible piping.
- If any leak is found, take care to avoid getting burned by exhaust gas.

5.4.18 Change Air Filter Element

Every 1,000 hours

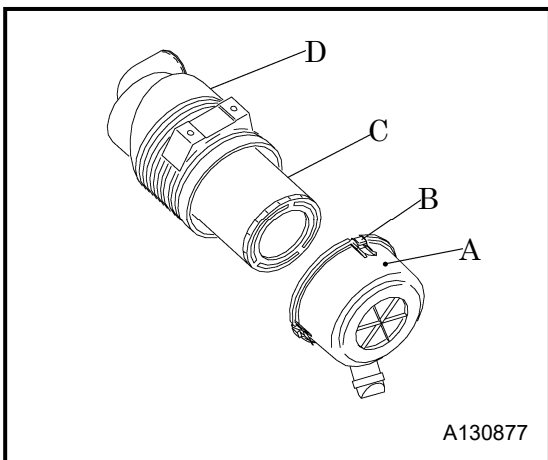

<Procedure>

1. After removing the cap [A] by loosening its cap fixing latch [B], clean its interior properly.
2. Remove element [C] and replace with a new one. (For part number, See 5.3)
3. When installing the cap, push the element into the case [D] firmly by hand, and then make sure that the cap fixing latches attach securely to the case. Lastly, tighten the latches.

IMPORTANT

- The air filter is an important part which is crucial to your machine's performance and life. Be sure to use genuine parts.

5. Periodic Inspection

5.4.19 Check Engine/Generator Anti-vibration Rubber

Once a year or 1,000 Hours

The anti-vibration isolation rubbers [A] are used to support the generator and engine. Check the rubber for any damage or deterioration due to oil adhesion.

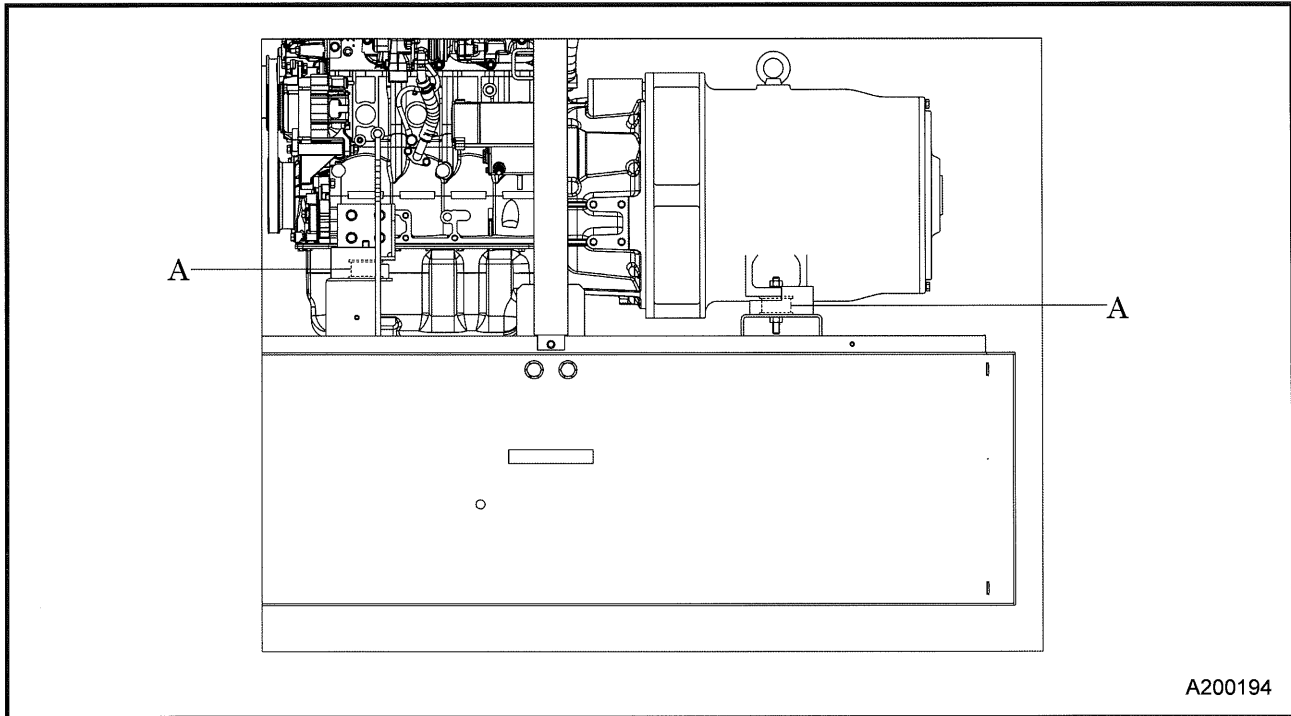

5.4.20 Check Each Rubber Hose

Every year or 1,000 Hours

Check all the rubber hoses for hardening, cracks, and fissures.

- If any hardening, cracks, or fissures are found on a hose (air filter, radiator, fuel and drain), replace it with a new one.
- Check each hose clamp and if any loose hoses are found, retighten them.
- Even before the maintenance interval comes, replace hoses if hardening, cracks, or fissures are found. When replacing, contact your nearest dealer.

5.4.21 Clean the Oil Fence and check for rust

Every year or 1,000 Hours

Expert knowledge is required to clean the inside of the oil fence and to check it for rust. Contact your nearest dealer.

5. Periodic Inspection

5.4.22 Change Coolant

Every 2 years

Be sure to stop the engine and let the coolant water sufficiently cool down before changing it.

<Procedures>

1. Remove the radiator cap [A] on the top of the radiator [D] and the drain plug [F], then open the drain valve [B] to drain the coolant.
 2. Loosen the drain plug [C] on the engine block to drain any coolant in the engine block.
 3. Drain the coolant in the reserve tank [E].
 4. Once the coolant has completely drained, close the drain valve [B] and the drain plug [C] and [F], and refill new coolant up to the base of the filler port of radiator [D]. Be sure to refill coolant up to the "MAX" on the reserve tank [E].
 5. After refilling coolant, securely attach the radiator cap [A] and the reserve tank [E] cap and operate the machine for about 2-3 minutes with no load.
 6. Stop the machine and allow coolant to cool before confirming the level of coolant in the reserve tank.
 7. Replenish the coolant if necessary.
- Refer to section 3.4.2 for reserve tank capacity details.

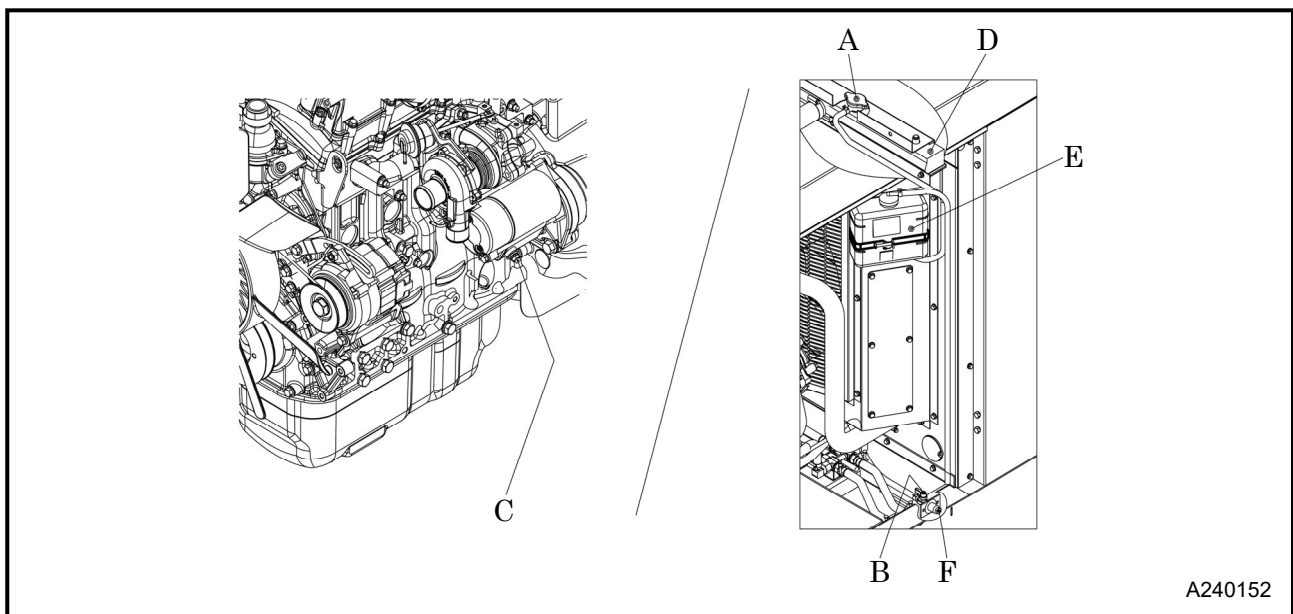

CAUTION

Caution when changing coolant

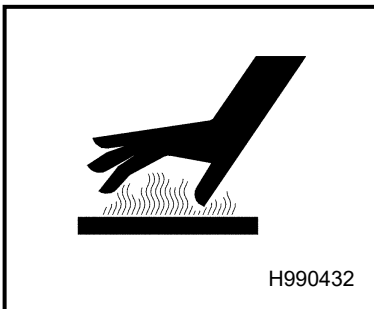

- When removing the radiator cap, lightly turn it and release the internal pressure without completely opening it once the first stage lock is released. After confirming that the internal pressure has been released, turn it while pushing in until the second stage lock is released. If this procedure is neglected, its inner pressure can blow off the radiator cap, and steam jetting out of the radiator may cause scalding burns.
- LLC (Antifreeze) is a toxic.
- In case of accidental ingestion, do not force vomiting and seek medical attention immediately.
- In case of contact with eyes, rinse with plenty of water and seek medical attention.
- When storing LLC (antifreeze), label it as LLC (antifreeze), seal it, and keep it out of reach of children.
- Beware of flames.

6. Storage and Disposal

6.1 Preparation for Long-term Storage

When storing for more than half a year without using the machine, perform the following measures and store it in a dry place with little dust.

- Put the machine in an enclosure if it is stored outside. Avoid leaving the machine outside with a sheet directly on the paint for a long period of time, as this may cause rusting.
- Perform the following procedures at least once every three months.

<Procedures>

1. Drain existing lubricant from the engine oil pan. Pour new lubricant in the engine to clean the internals of the engine. After running it for a while, drain it again.
2. Spread lubricant on all moving parts.
3. Completely charge the battery and disconnect grounding wires. If possible, remove the battery from the machine and store it in a dry place. (Charge the battery at least once every month.)
4. Drain coolant and fuel from the machine.
5. Seal air-intake port of engine and other openings like the muffler with a vinyl sheet, packing tape, etc., to prevent moisture and dust from getting in the machine.
6. Measure the insulation resistance of the generator, and make sure that it is greater than 1M Ohms. (See 5.4.8)
7. Be sure to repair any trouble and maintain the machine so that it will be ready for the next operation.

6.2 Disposal of Product

- Be sure to drain the engine oil, coolant, and fuel before disposing of this machine. If you require any additional information, contact your nearest dealer.

7. Specifications

7.1 Specifications

Model		SDG45S-8E2			
Generator	Exciting system		Brushless		
	Armature Connection		Double star	Parallel zig-zag	
	Phase number		3 Phase – 4 wire	Single Phase 3 wire	
	Power Factor	%	80	100	
	Frequency	Hz	60		
	Rated Output	kVA (kW)	45(36)	28.3(28.3)	
	Voltage	V	240	480	240/120
	Amps	A	108	54	118
Engine	Model		ISUZU BP-4LE2X		
	Type		4 Cycle, water cooled, direct injection, Turbocharged		
	Aftertreatment		DOC		
	No. of Cylinders		4		
	Displacement	cu.in. (liters)	133 (2.179)		
	Rated Output	HP (kW)	57.7 (43.0)		
	Engine Speed	RPM	1,800		
	Lubricating Oil Capacity	gal. (liters)	2.7 (10.4)		
	Coolant Capacity (including radiator)	gal. (liters)	2.5 (9.5)		
	Battery		80D26R (12V)		
	Fuel Tank Capacity	gal. (liters)	80.5 (305)		
Dimensions	Length	in. (mm)	74.8 (1,900)		
	Width	in. (mm)	38.2 (970)		
	Height	in. (mm)	61.4 (1,560)		
	Dry Weight	lbs. (kg)	2,337 (1,060)		
	Operating Weight	lbs. (kg)	2,954 (1,340)		
Others	Oil Fence Capacity	gal. (liters)	23 (100)		

7.Specifications

7.2 Outline drawing

[Unit : in.]

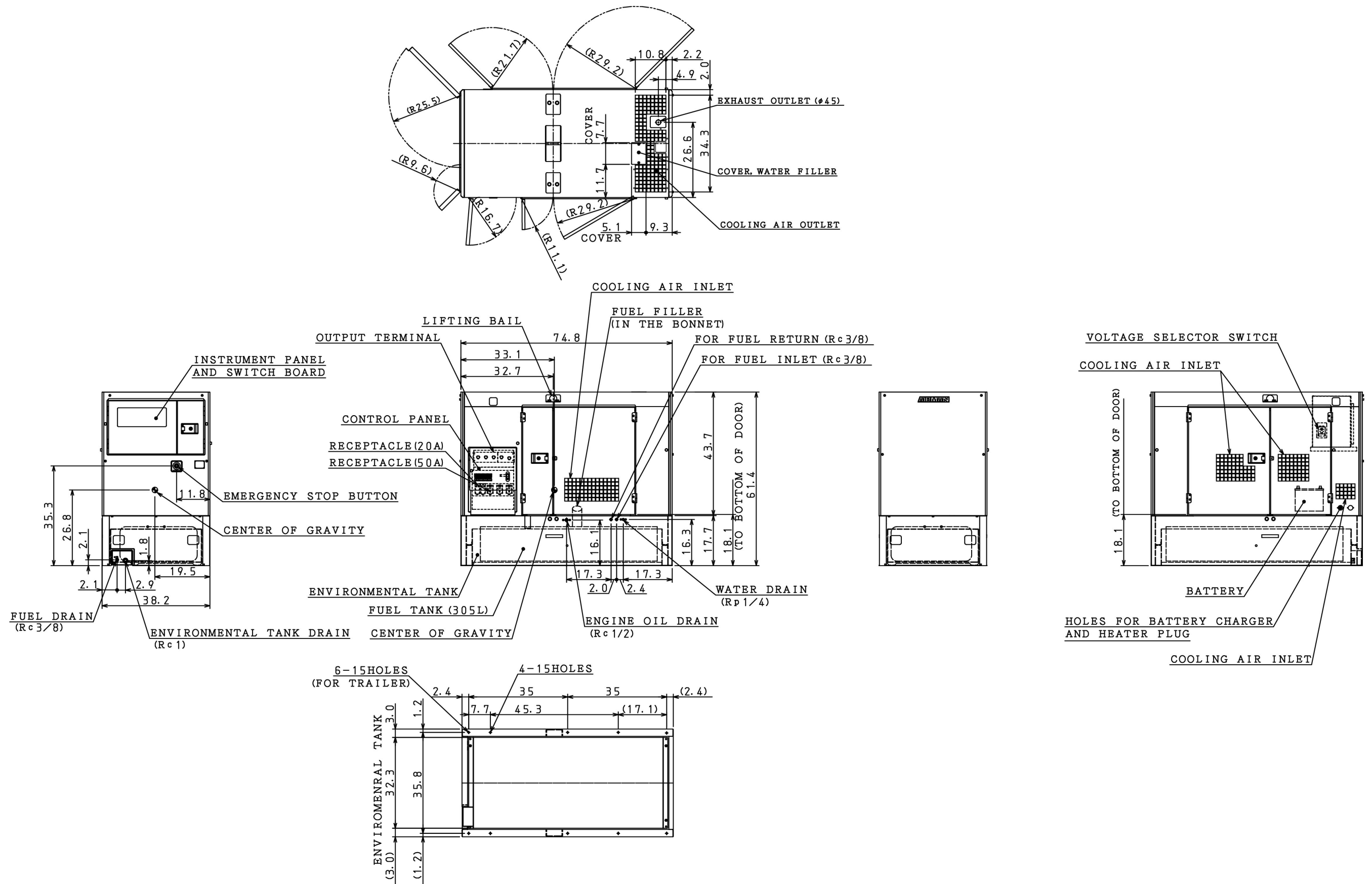

7.Specifications

[Unit : mm]

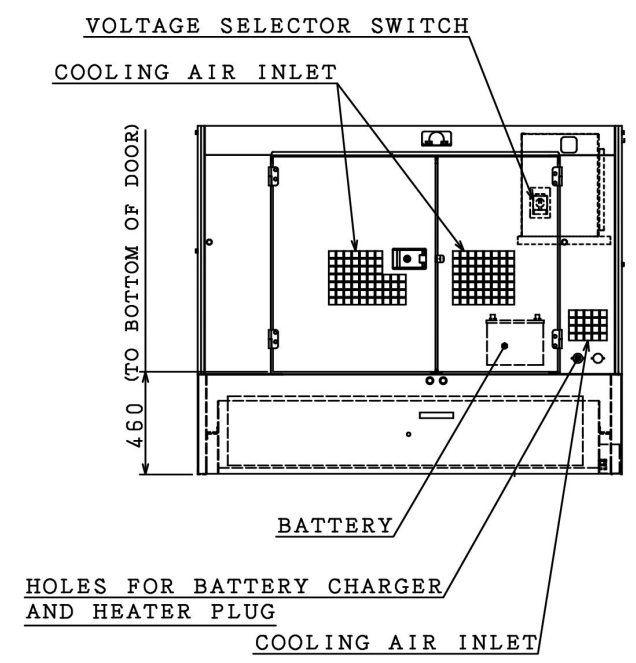
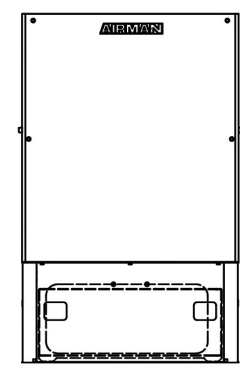
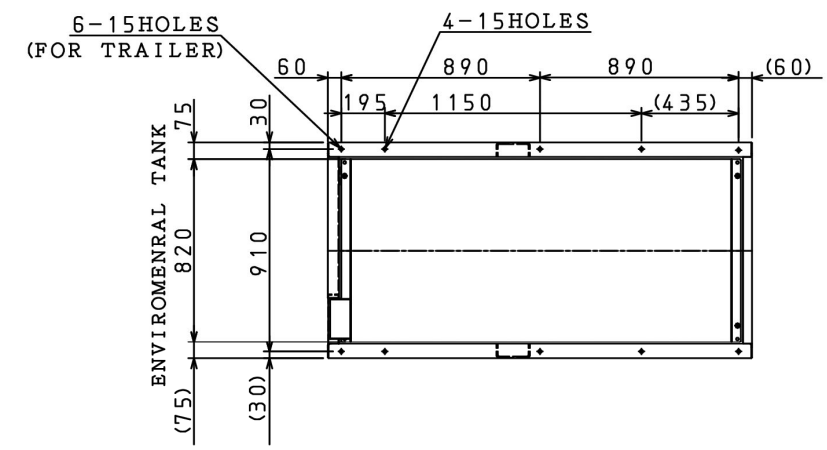
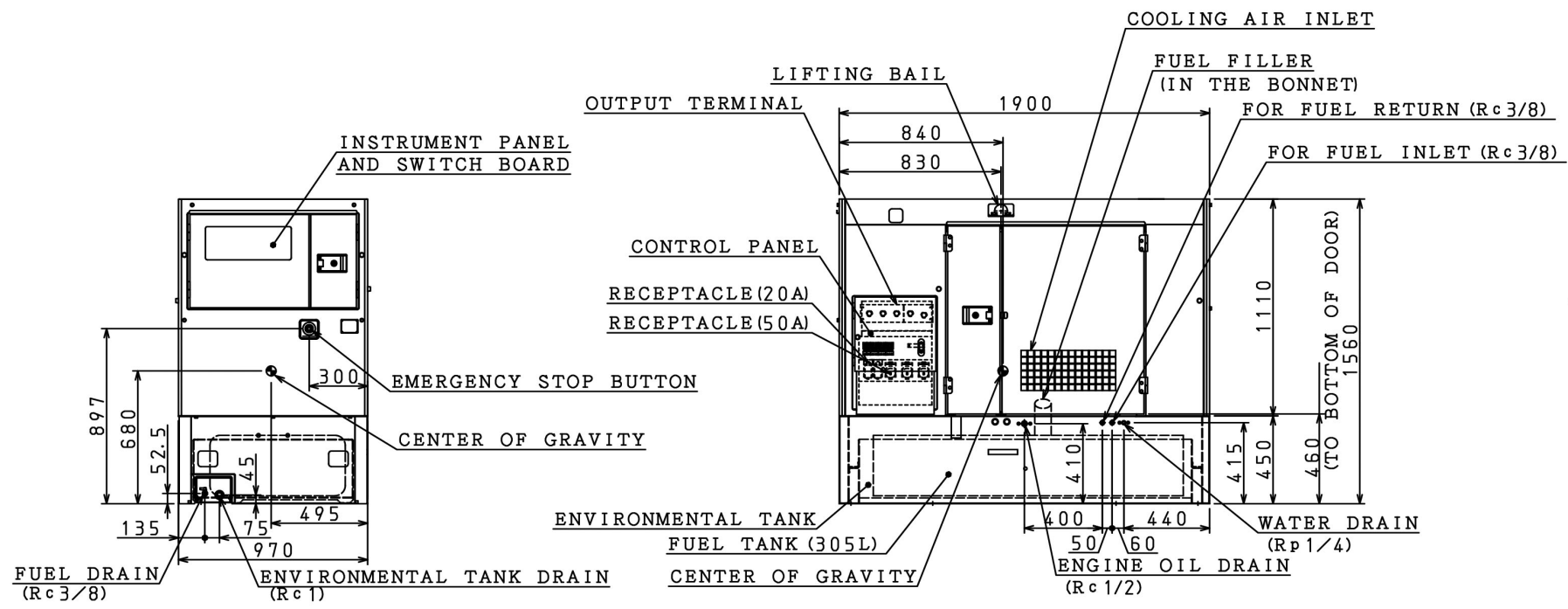
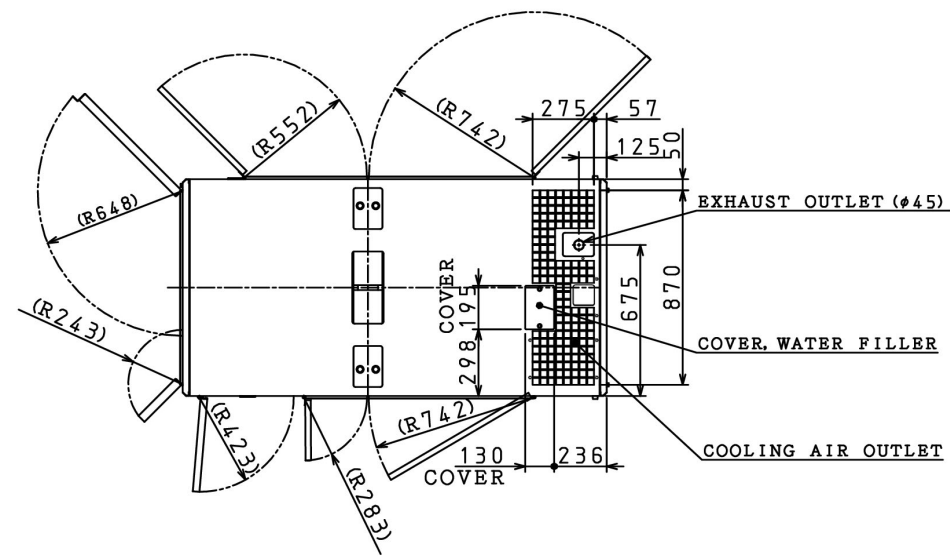

7. Specifications

7.3 Generator Wiring Diagram

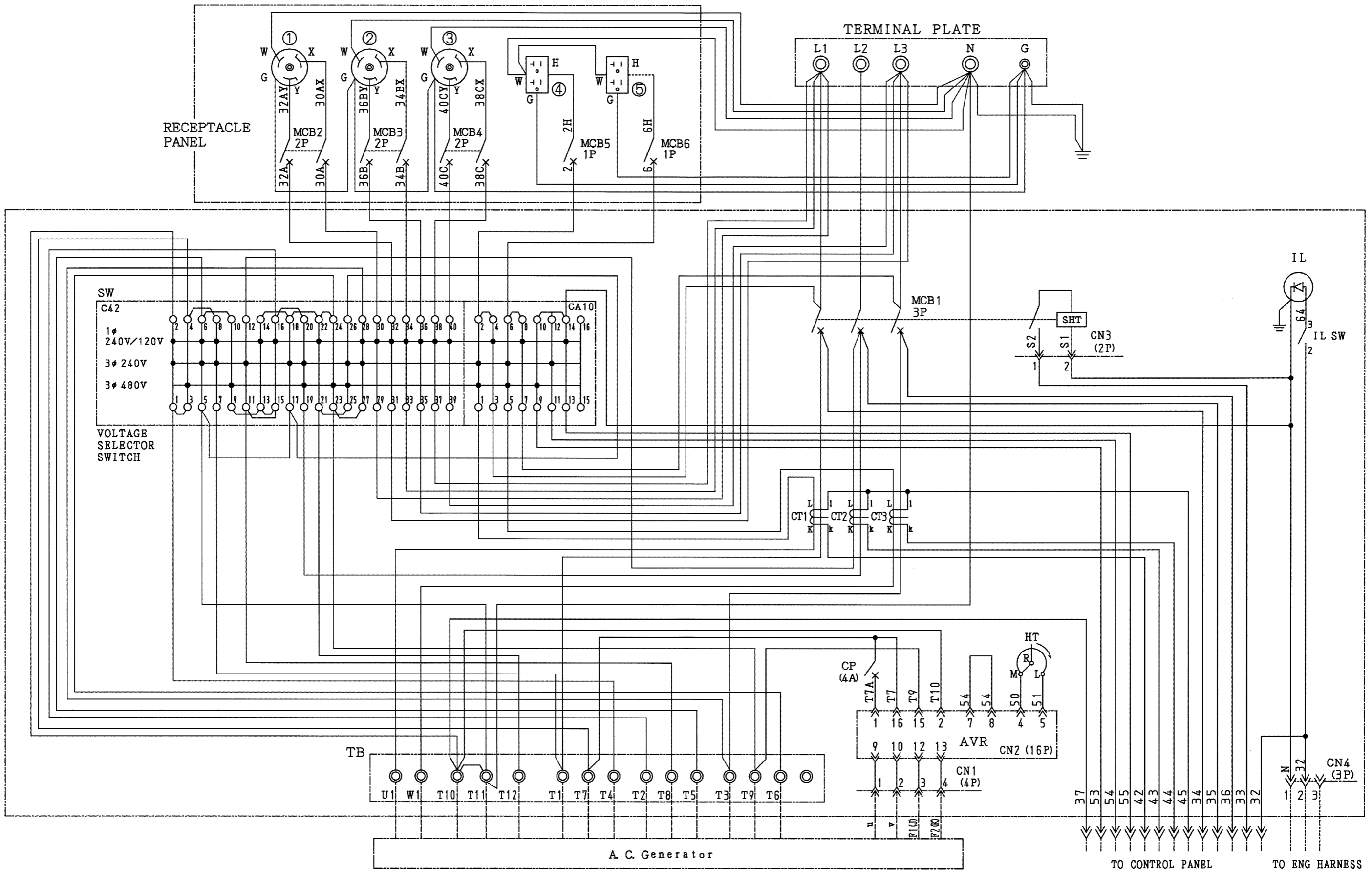

7. Specifications

7.4 Engine Wiring Diagram

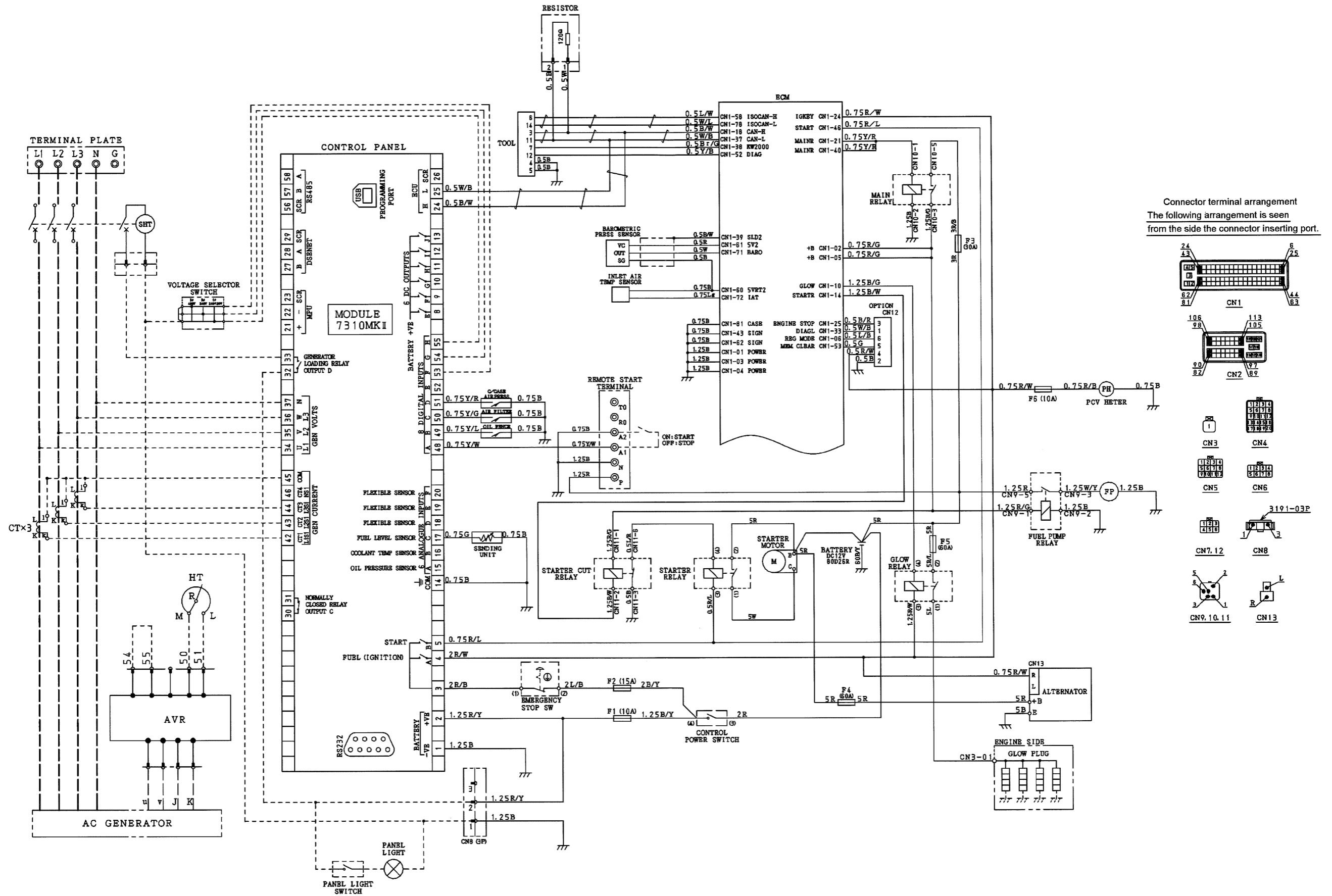

Connector terminal arrangement
The following arrangement is seen
from the side the connector inserting port.

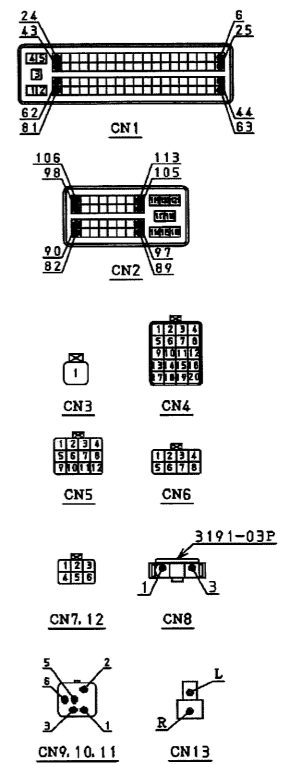

7.Specifications

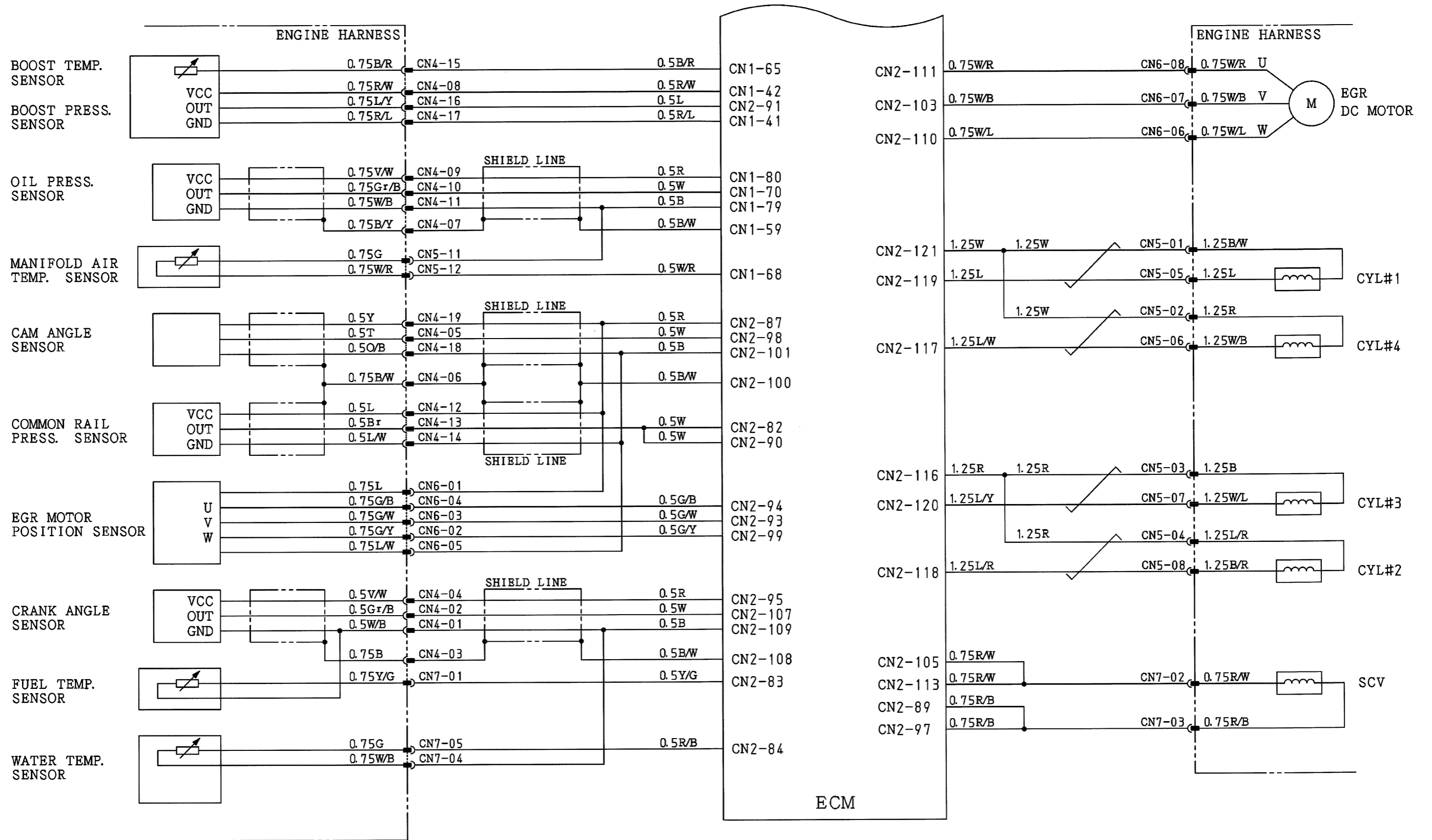

7.Specifications

7.5 Piping Diagram

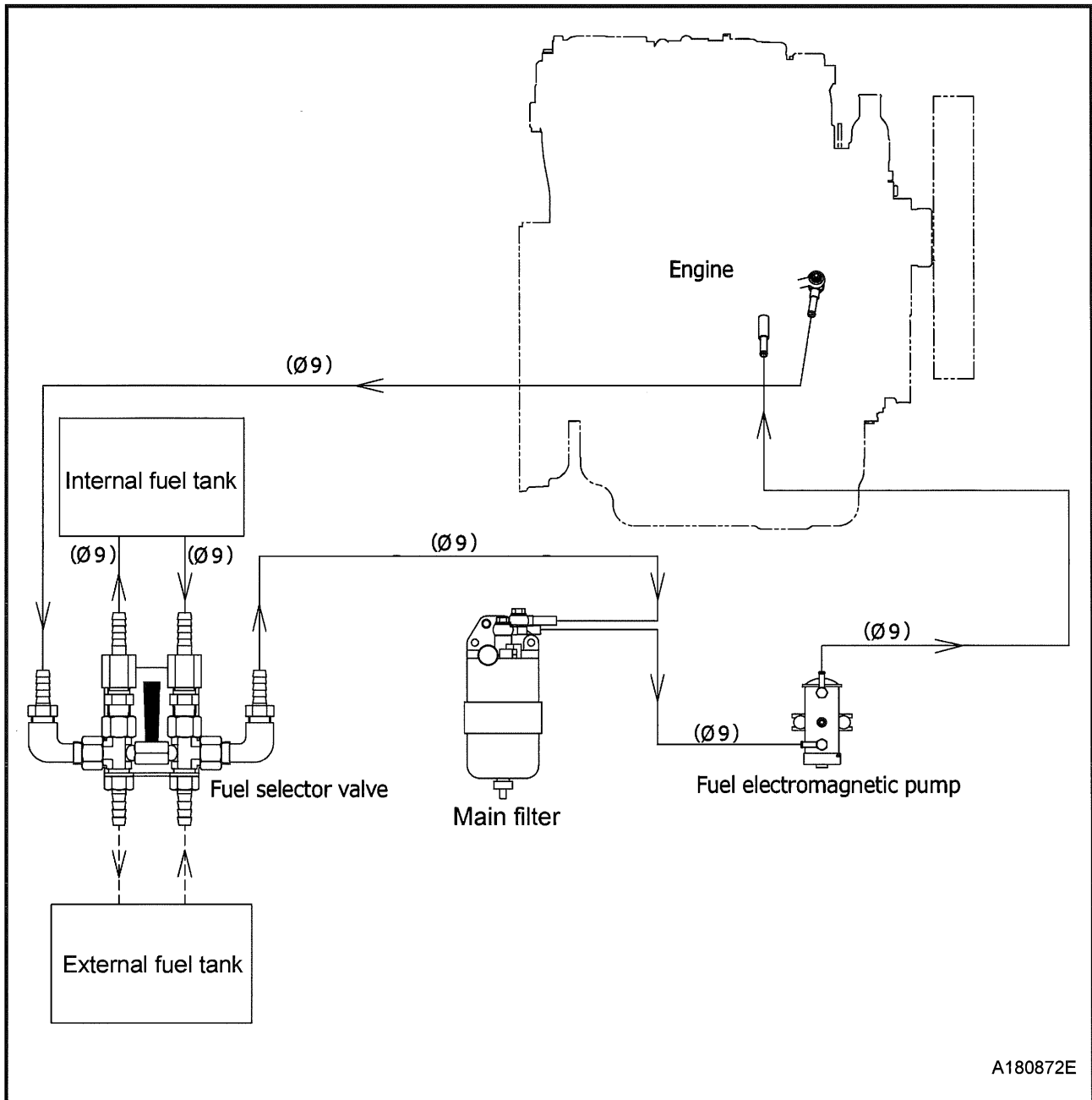

A180872E

HOKUETSU INDUSTRIES CO., LTD.

8TH FLOOR SHINJUKU SAN-EI BLDG,
22-2 NISHI-SHINJUKU 1-CHOME, SHINJUKU-KU
TOKYO 160-0023 JAPAN
TEL:81-3-3348-7281
FAX:81-3-3348-7289
URL:<http://www.airman.co.jp>

Copyright (C) 2022 HOKUETSU INDUSTRIES CO., LTD. All Rights Reserved.

39600 04551

Printed JUL. 2024

AIRMAN
HOKUETSU INDUSTRIES CO., LTD.