



# ANA

We make your world easier.



**EBOSS<sup>®</sup>**  
**125-65**  
 -HYBRID SYSTEM-  
 62 / 125 kVA  
 PRIME / PEAK POWER

U.S. Patent No. 12,283,8222

AIRMAN<sup>®</sup> Generator Tier 4F Final | Isuzu<sup>®</sup> 4JJ1X Engine

## EBOSS<sup>®</sup> HYBRID ENERGY SYSTEMS BENEFITS

**20X**

UP TO 20X THE  
CYCLE LIFE OF  
NMC/LFP BATTERIES



SAFE BATTERY  
TECHNOLOGY  
NO THERMAL RUNAWAY

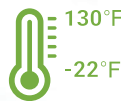

WIDEST  
TEMPERATURE  
OPERATING RANGE

**1Φ AND 3Φ**

SIMULTANEOUS  
1 AND 3 PHASE  
OUTPUT VOLTAGES



REMOTE ACCESS  
MONITORING &  
TRACKING



INDUSTRIAL  
GRADE  
INVERTERS

# JOURNEY TO ZERO<sup>®</sup>

# ▶ How It Works

**EBOSS®**  
125-65

The generator charges the EBOSS® battery, then shuts down while the EBOSS® powers the load until the battery is depleted. This cycles multiple times per day, allowing the generator to run less frequently, reducing fuel consumption, run time, and emissions.

## Charging the EBOSS®

The generator charges the EBOSS® battery. Once the battery is fully charged, the generator shuts off.

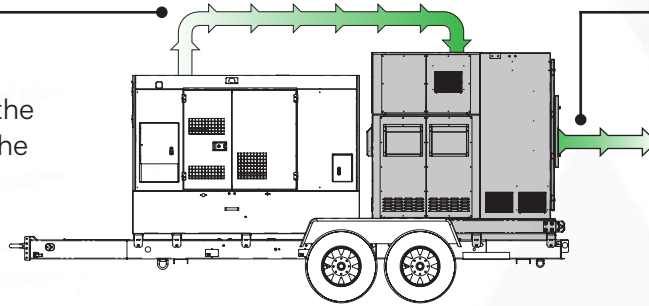

## Powering the Load

The stored energy in the battery provides power to the load. Once the battery discharges to 15% capacity, the generator starts up again to charge the battery.

## EBOSS® Advantage

### // Ease of Use

EBOSS® is easier to use, operate, and integrate as a hybrid system with a standard diesel generator.

### // Scalability

EBOSS® is easily scalable to dozens of units without any additional hardware or specialty controls required.

### // Battery Chemistry

EBOSS® uses LTO battery chemistry, which is much more efficient and safer than the competition's LFP.

### // Battery Life

EBOSS® LTO battery packs can last 40+ years (up to 10x longer than the competition's LFP).

### // Energy Uptime

Ultra high cycle life LTO batteries can fully charge in 45 min, the competition charges in 4+ hours.

### // Telematics

EBOSS® Telematics provides remote monitoring and reporting 24hrs/day anywhere in the world.

### // Product Support

World class product support, with trained and knowledgeable technicians answering your calls 24hrs/day.

### // Climate Versatility

EBOSS® performs effortlessly in virtually any climate or environment around the world from -22°F to 130°F (-30°C to 54°C).

# ► Specifications

**EBOSS®**  
125-65

EBOSS® Specifications		
Generator Input	52kW max	
Battery Capacity	50kWh	
EBOSS® Output	100kW max (120Amp Load)	
Frequency	60Hz	
Total Battery Life (Energy Throughout)	4,000 MWh	
Battery Cycles / Battery Life (100° F)	80K / 41 Years	
Battery Chemistry	Lithium Titanium Oxide (LTO)	
Operating Temp	-22°F to 130°F (-30°C to 54°C)	
Inverter Cold Start Temp	14°F (-10°C) minimum	
Charge Time (No Load)	~45 min	
Telematics	Monitoring & Reporting	
Parallel Capability	Unlimited	
Dimensions (LxWxH)	Skid 90.29" x 58.89" x 96.36" (2293mm x 1496mm x 2448mm)	
	Hybrid 233.9" x 83.73" x 105.5" (5941mm x 2127mm x 2680mm)	
Weight (Empty / Fueled)	Power Module 7,623lbs (3,458kg)	
	Hybrid 12,000lbs / 13,000lbs (5,443kg / 5,897kg)	
Maximum Intermittent Power Output (Battery SOC Greater than 5%)		
Three Phase	125kVA / 100kW	
Simultaneous Voltage (Three Phase)	208 / 480	
Single Phase	N/A	
Simultaneous Voltage (Single Phase)	120	
Frequency	60Hz	
Voltage Regulation	Adjustable	
Maximum Continuous Power Output (Battery SOC at 0%)		
Generator	Airman SDG65	
Generator Charge Rate	65kVA / 52kW	
Three Phase Output	62kVA / 50kW	
Single Phase Output	2.4kW x 2	
Simultaneous Voltage (Three Phase)	208 / 480	
Simultaneous Voltage (Single Phase)	120	
Warranty		
2 Year EBOSS®	7 Year Battery	
Optional Equipment		
Cold Weather Package	Arctic Package	600V Package

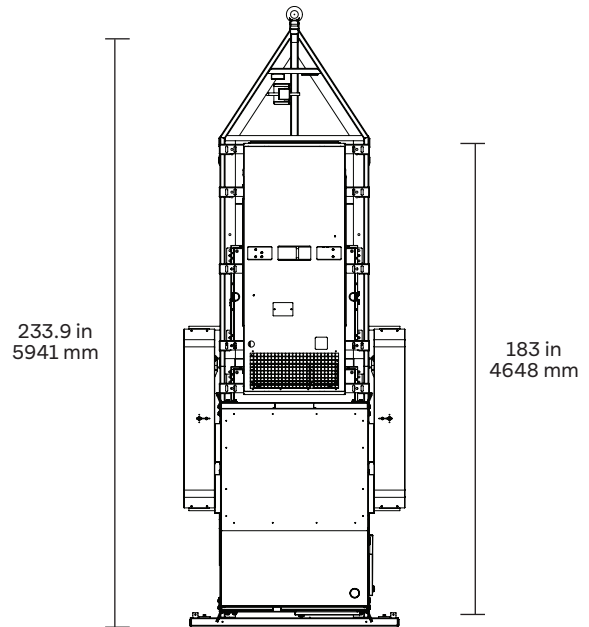
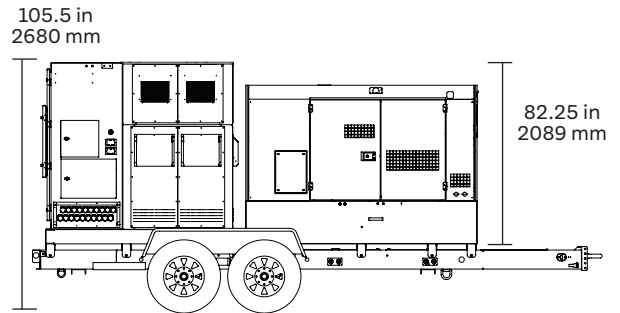
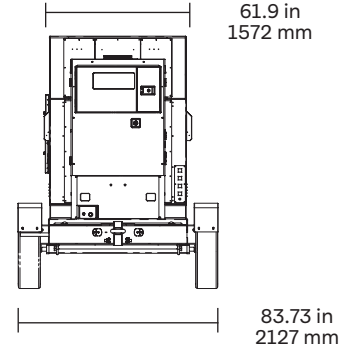

EBOSS® Breaker Type		Rating	QTY
Input	Generator	125A	1
	480V 3 Phase	225A	1
Output	208V 3 Phase	225A	2
	120V GFCI	20A	2

\*Specifications shown subject to change without notice. Please contact ANA for current specifications and model information.

Learn More About



**ANA**

We make your world easier.

**ANACORP.COM**



**EBOSS<sup>®</sup>**



SOLD AND SERVICED BY

**Cypress, CA // Henderson, NV // Spartanburg, SC**  
**Executive Offices // 1770 Raiders Way, Henderson, NV 89052**  
**1 (562) 450-3570 // sales@anacorp.com // www.anacorp.com**

\*Specifications shown are subject to change without notice.  
Please contact ANA, Inc for current specifications and model information.

EB125-65SV1.26