



ANA

ENERGY

HYBRID ENERGY SYSTEM

EBOSS™

220 kVA

- HYBRID SYSTEM -



Operation Manual

V1 - 12.10.24

PN: 3000000213

Page Intentionally Left Blank

Thank you for purchasing the EBOSS™.

The ANA EBOSS™ is a hybrid energy system that integrates a very efficient diesel generator with our ultra-high cycle life lithium battery storage system optimized to reduce noise, emissions, maintenance, and fuel consumption.

The EBOSS™ Human Machine Interface (HMI) is the central control software and hardware of the system, accessed via a touchscreen control panel enabling high-level monitoring and control over the entire system.

The EBOSS™ HMI platform allows owners to manage their single unit or complete fleet of EBOSS™ units. It enables monitoring and reporting on each unit and the entire fleet at multiple levels to support the various customer user groups from end users to fleet managers to service engineers. The HMI provides the best means of managing the energy storage system and generator allowing users to get the most out of both systems and respond to customers' needs more effectively.

This manual provides the steps needed to operate, manage, and maintain the EBOSS™ safely and effectively throughout its long operational life. ANA provides a two year base warranty on the generator and all its associated equipment and a seven year product warranty on the battery. ANA offers various levels of service contracts designed to suit your needs so please contact us about your requirements.

Please note, due to constant product improvement, the specifications, photos, and procedures listed in this manual are subject to change without notice. Please contact ANA directly for the most up to date information on the EBOSS™ product line.

ANA, Inc.
1740 Raiders Way
Henderson, NV 89052
anacorp.com

Sales and Support
Phone: 1-562-450-3570 Opt 3
Email: support@anacorp.com
Email: sales@anacorp.com

Table of Contents

06 | **About ANA**

Information about ANA, Inc.

07 | **About EBOSS™**

Features, benefits, and overview of the EBOSS™.

08 | **Specifications**

EBOSS™ specifications, dimensions, and decals.

22 | **Safety**

Safety explanation and warning symbols.

26 | **Definitions**

Definitions and acronyms used in this manual.

27 | **Transport and Towing**

How to safely transport and tow the EBOSS™ unit.

38 | **Fueling & Grounding**

Safe fueling and grounding procedures.

39 | **Setup for Operation**

How to setup the EBOSS™ for operation.

40 | **Start Up / Shut Down**

How to start up the unit and safely shut it down.

41 | **Power Sources**

All available power sources provided by the EBOSS™.

42 | **Batteries**

Battery function and operation.

43 | **Operation Sequence**

How to safely operate the EBOSS™.

44 | Cold Weather

Operating the EBOSS™ in cold weather.

46 | Parallel Mode

Operating the EBOSS™ in parallel mode.

49 | HMI Display

Operation of the Human Machine Interface (HMI).

51 | Battery Information

Battery information shown in the HMI display.

52 | Fault Information

Fault information shown in the HMI display.

53 | Trending Information

Trending information shown in the HMI display.

54 | Remote Monitoring

Information about EBOSS™ telematics.

54 | Maintenance

Maintenance procedures of the EBOSS™.

56 | Storage

Information about proper storage of the EBOSS™.

58 | Fault / Alarm Index

Index of faults and alarms.

66 | Troubleshooting

Troubleshooting information for the EBOSS™.

70 | Warranty Info

Warranty information about the EBOSS™.

▶ About ANA

Founded in 2017, ANA, Inc is a customer focused, rapidly growing company specializing in the construction, industrial, utilities, telecom, and rental equipment sectors. ANA is the exclusive North American supplier of AIRMAN mobile generators and air compressors.

ANA also designs and manufactures the EBOSS™, a hybrid energy system revolutionizing the mobile power generation industry.

▶ ANA Locations



Cypress, CA

- Engineering
- Planning
- Warehouse



Henderson, NV

- Corporate HQ
- Engineering
- Production
- Training



Spartanburg, SC

- Production
- Distribution
- Warehouse



▶ About EBOSS™

The EBOSS™ hybrid energy system provides an energy efficient power generation solution that provides clean power, long battery life, reduced emissions, lower maintenance costs, with an improved ROI over just running a generator alone. Using a generator to charge battery packs that provide outgoing electrical power, the EBOSS™ significantly reduces generator runtime and fuel consumption.

▶ How It Works

The generator starts up and charges the EBOSS™ battery. Once fully charged, the generator shuts off and the EBOSS™ provides several hours of clean, quiet power to the load. When the EBOSS™ battery drops below 15% capacity, the generator starts up again to charge the EBOSS™. In low load applications the EBOSS™ can be fully charged in less than an hour.

Charging the EBOSS™

The generator charges the EBOSS™ battery. Once the battery is fully charged, the generator shuts off.

Powering the Load

The stored energy in the battery provides power to the load. Once the battery discharges to 15% capacity, the generator starts up again to charge the battery.

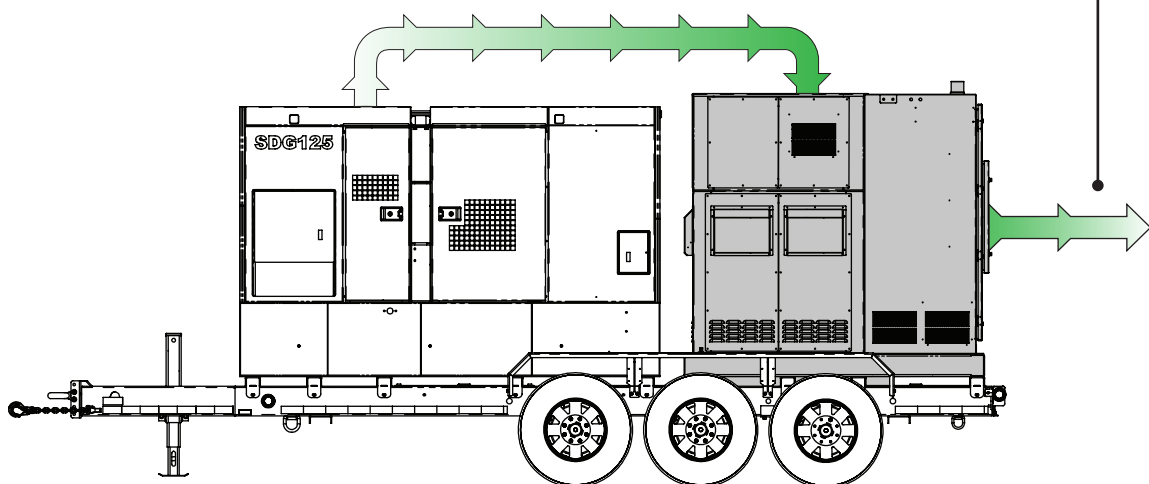

▶ EBOSS™ Specifications

EBOSS™ 220kVA specifications.

| Specifications | EBOSS™ 220kVA |
|---------------------------------------|----------------------------------|
| Hybrid Energy System | ANA EBOSS™ |
| Prime Output | |
| Three - Phase | 220 kVA / 176 kW |
| Frequency | 60 Hz |
| Voltage (Three - Phase), Simultaneous | 208 / 480 |
| Voltage Regulation | Adjustable |
| Output Panel | |
| Single - Phase (120V) | 20A |
| Three - Phase (208V) | 208V Cam-Loks (x 2) |
| Three - Phase (480V) | 480V Cam-Loks (x 2) |
| Controls | |
| Control Panel | 10" Full Color Touch Screen |
| Telematics | Generator & EBOSS™ |
| ESG Reporting | Yes |
| Technology | |
| Battery Chemistry | Lithium Titanate Oxide (LTO) |
| Inverter | Industrial Grade 3-Phase, 176 kW |
| Battery System Voltage | 360V - 648V |
| DC BUS Voltage | 600+ DC |

▶ EBOSS™ Specifications (Cont)

EBOSS™ 220kVA specifications.

| Battery Life* | EBOSS™ 220kVA |
|--|--------------------------------|
| Battery Type | Lithium Titanate Oxide (LTO) |
| Battery Size | 75 kWh |
| Est. Life Cycle @ 77°F Laboratory Cond. | 90k Cycles at 90% DOD |
| Est. Life Cycle @ 100°F Enclosure Temps. | 80k Cycles at 90% DOD |
| Battery Life (100°F) @ 3 kW Average Load | 41 Years |
| Operating Temperatures | |
| Inverter Cold Start Temperature (min) | 14°F (-10°C) |
| Running Operating Temperature | -22°F to 130°F (-30°C to 54°C) |
| Arctic Package Operating Temp (optional) | -50°F to 130°F (-45°C to 54°C) |
| Battery Charging Temperature | -22°F to 130°F (-30°C to 54°C) |
| Weights & Dimensions | |
| Length x Width x Height (EBOSS™ only) | 90.24" x 61.72" x 101.72" |
| Skid Weight (EBOSS™ only) | 8,671 lbs |
| Length x Width x Height (w/ trailer and generator) | 255.12" x 82.44" x 105.5" |
| Total Weight | 16,000 lbs |
| Warranty | |
| EBOSS™ Only | 2 Years |
| EBOSS™ with Trailer & Generator | 2 Years, 2000 Hours |
| Manufacturer Battery Warranty | 7 Years |
| Service & Support | 24/7, 365 Days |
| Training | |
| EBOSS™ Training | Henderson, NV or On Location |

*Battery expected to retain 95% of its life after 7 years under 24/7 operation at 3kW average load.

▶ EBOSS™ Components

EBOSS™ 220kVA hybrid component information.

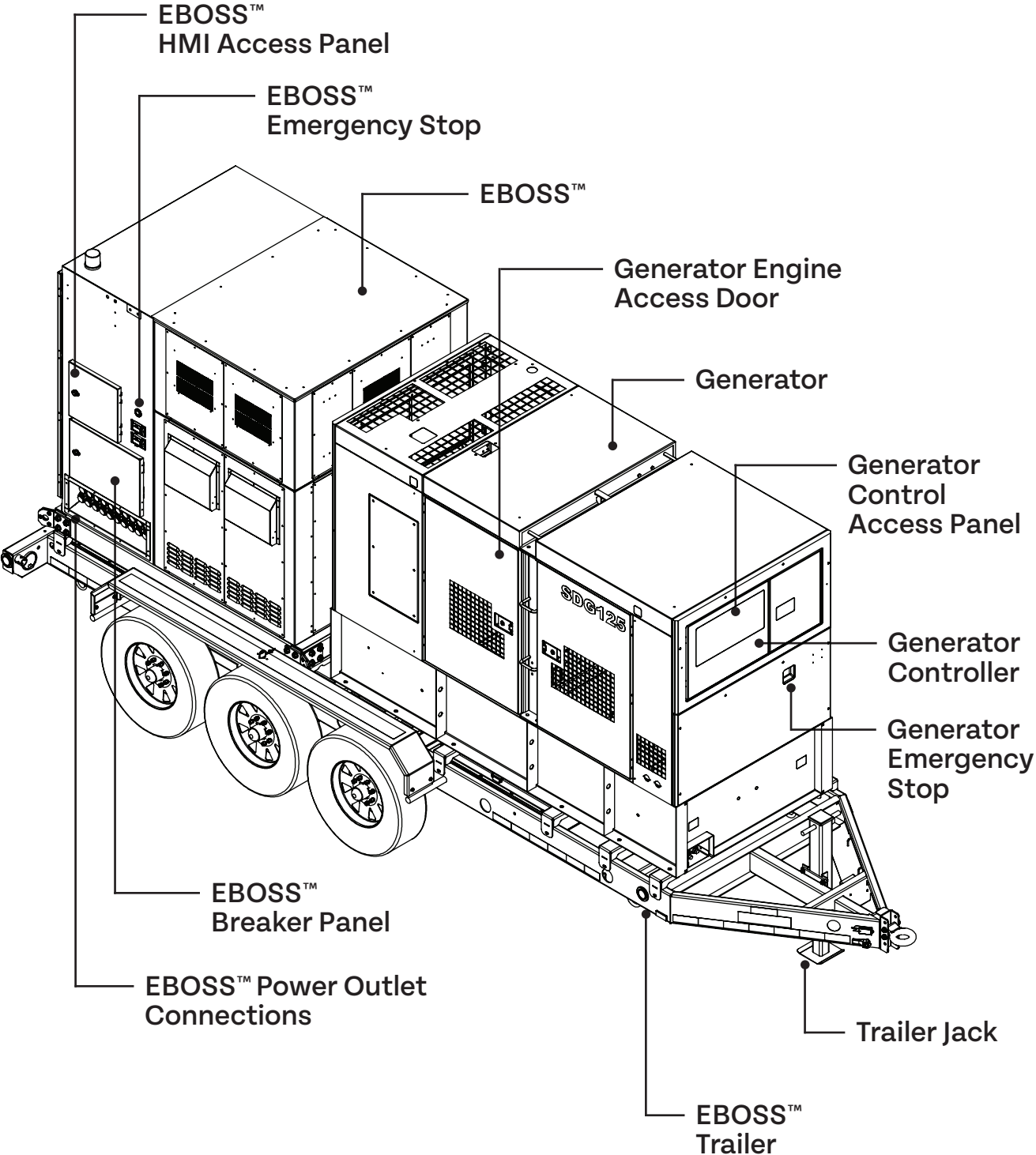

▶ EBOSS™ Components

EBOSS™ 220kVA hybrid component information.

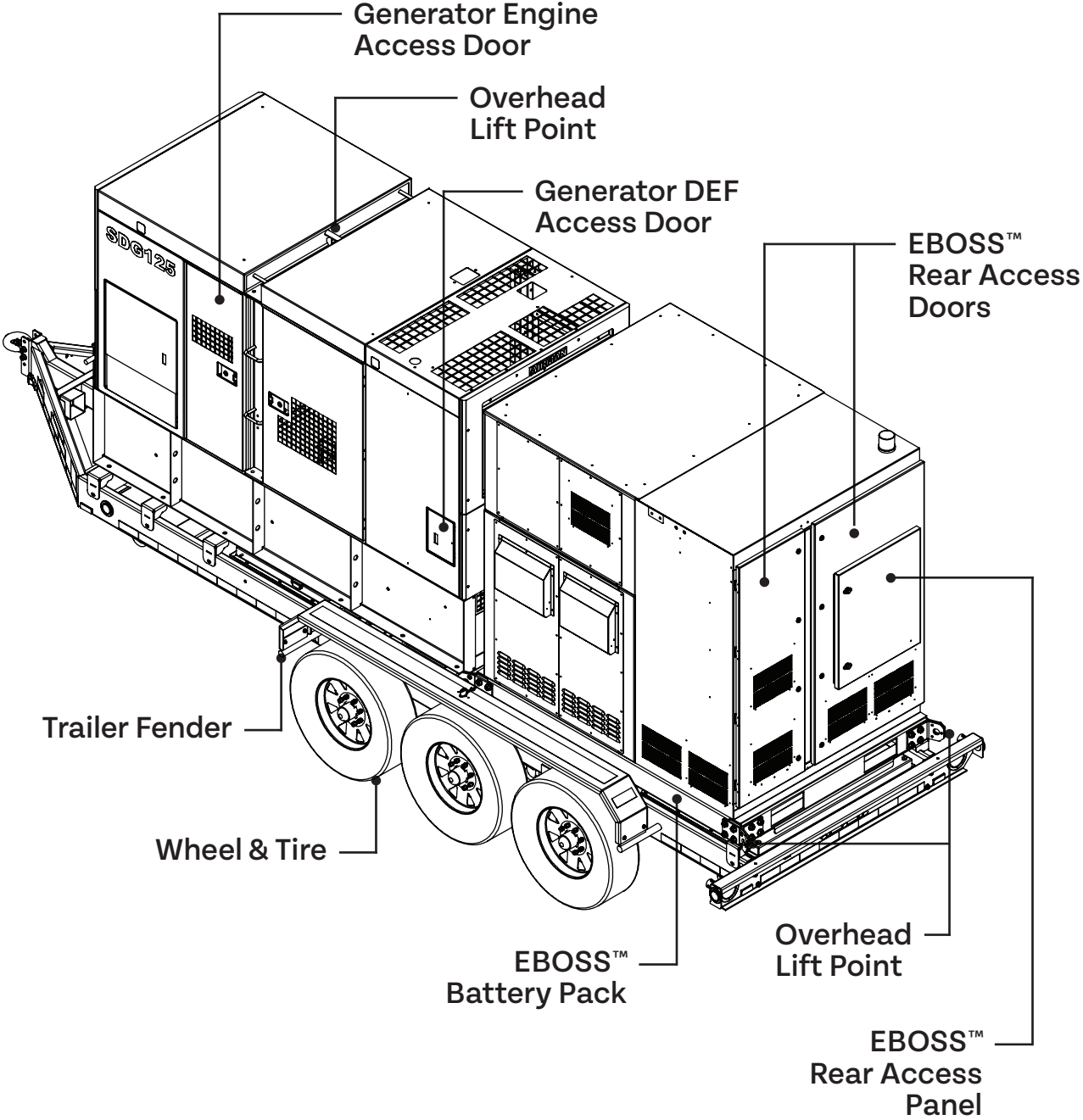

▶ EBOSS™ Dimensions

EBOSS™ 220kVA hybrid specifications.

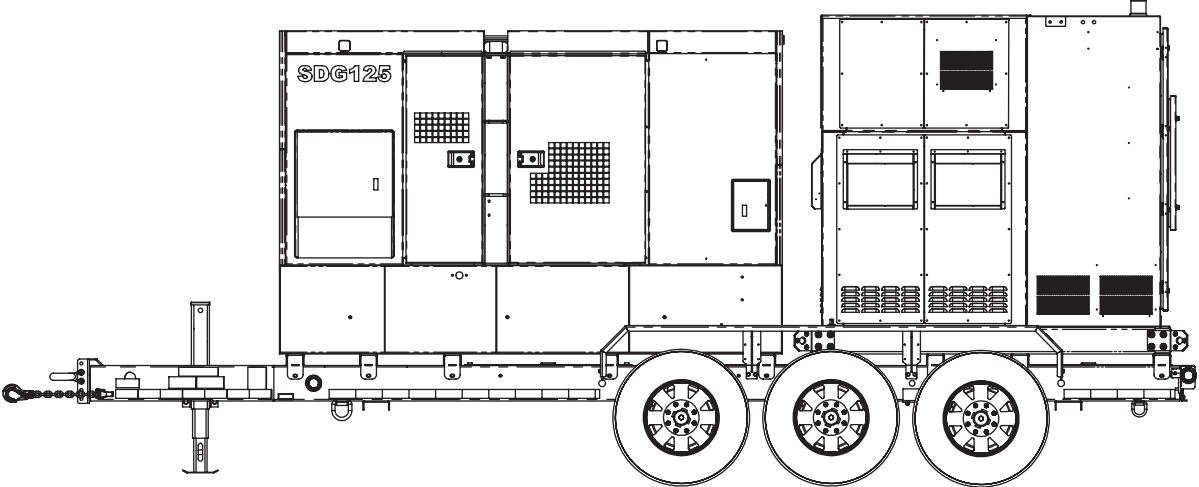
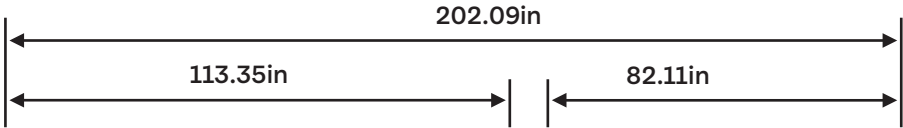
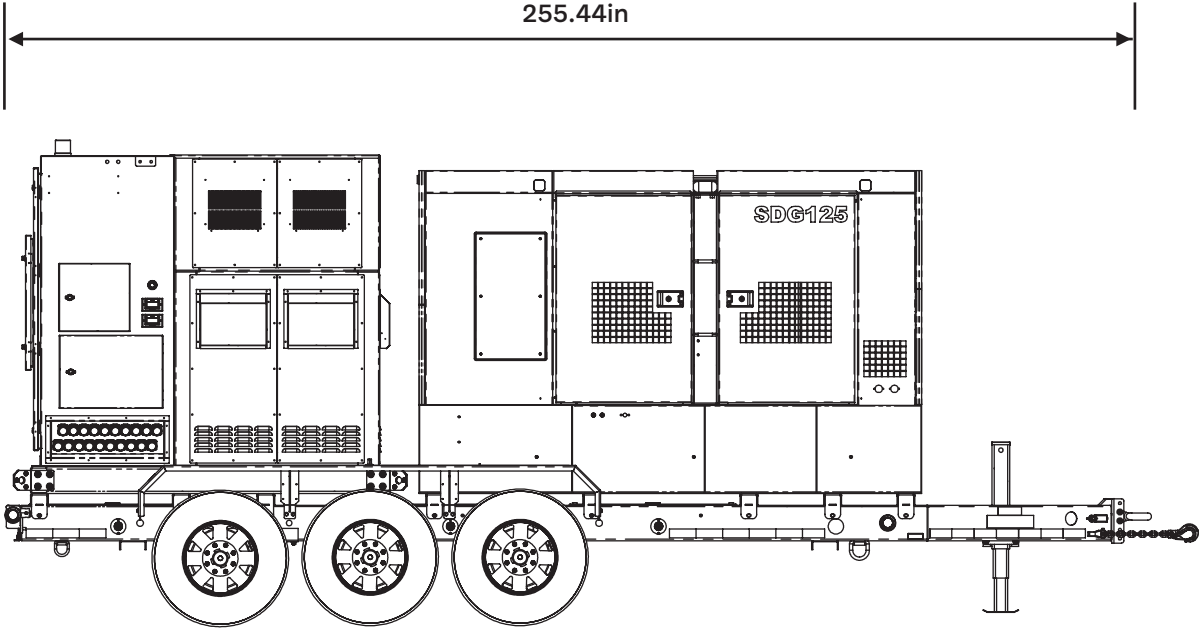

▶ EBOSS™ Dimensions

EBOSS™ 220kVA hybrid specifications.

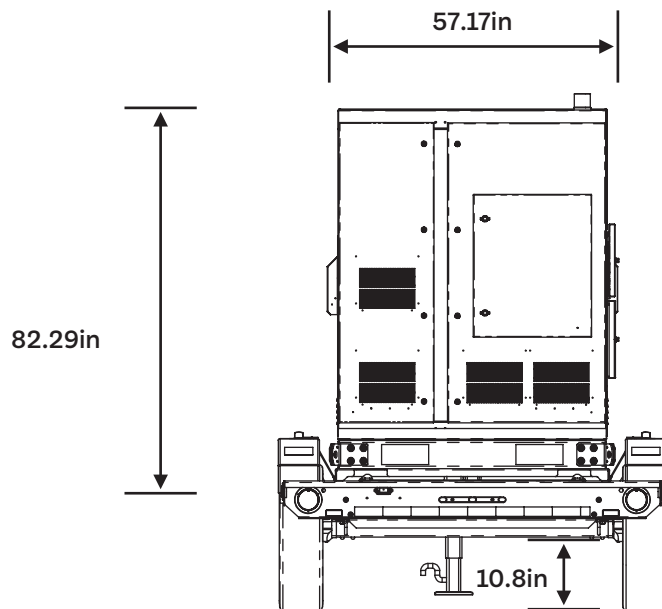
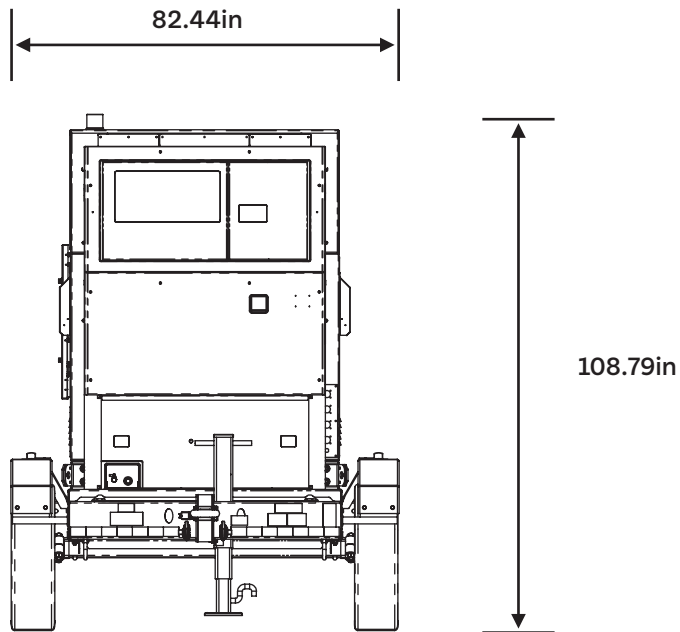

▶ EBOSS™ Decals

EBOSS™ 220kVA hybrid decal locations.

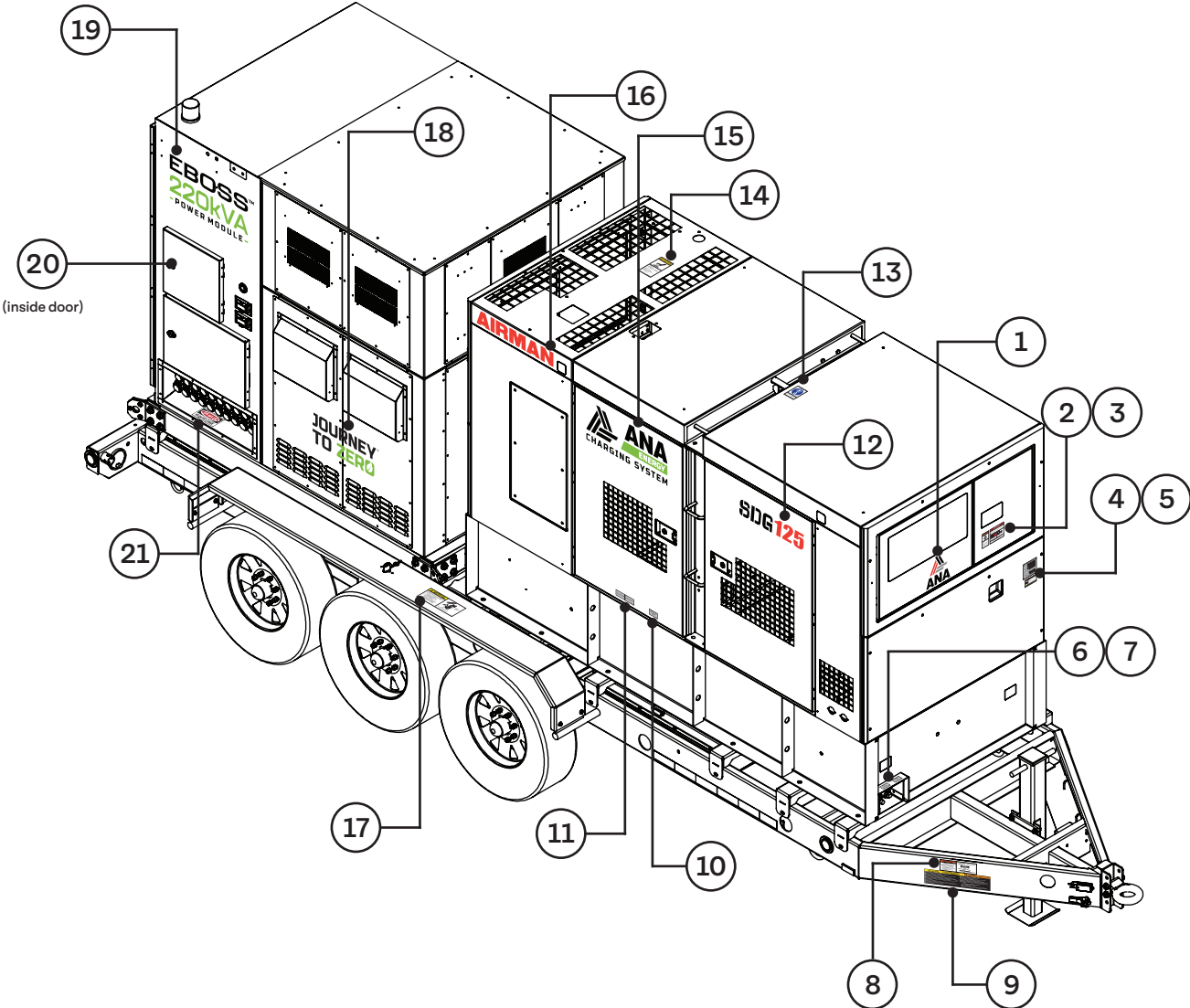

▶ EBOSS™ Decals

EBOSS™ 220kVA hybrid decal locations.

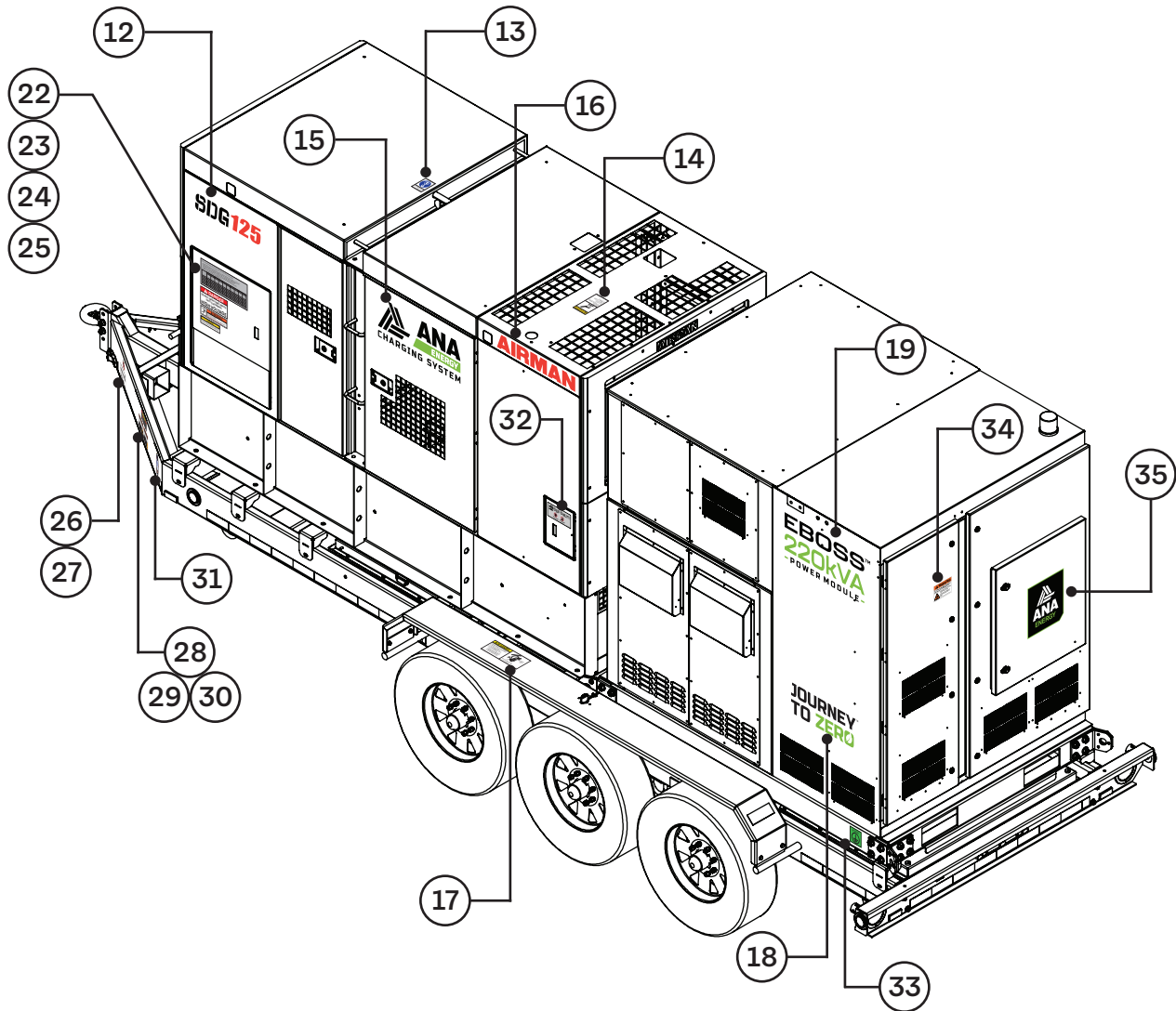

EBOSS™ Decals

EBOSS™ 220kVA hybrid decal descriptions.

| EBOSS™ Decals | | | |
|----------------------|--------------------------------|----|------------------------------|
| 1 | ANA logo | 19 | EBOSS™ 220kVA logo |
| 2 | Warning - Exhaust Fumes | 20 | Quick Start Guide |
| 3 | Danger - Carbon Monoxide | 21 | Danger - High Voltage |
| 4 | Generator Data Plate | 22 | Maximum Power Chart |
| 5 | Warning - Diesel Exhaust | 23 | Danger - Do Not Open Panel |
| 6 | Fuel Drain | 24 | Warning - Do Not Touch |
| 7 | Containment Drain | 25 | Caution - Power Distribution |
| 8 | Warning - Overload Hazard | 26 | Tire & Loading Information |
| 9 | Safe Trailer Towing Guidelines | 27 | Trailer VIN |
| 10 | Radiator Drain | 28 | Trailer Tow Warnings |
| 11 | Fuel Return / Inlet | 29 | Warning - Pintle Hitch |
| 12 | SDG125 logo | 30 | Warning - Ball Hitch |
| 13 | Lift Point Location | 31 | NATM MFG Badge |
| 14 | Caution - Do Not Open Rad Cap | 32 | DEF Only |
| 15 | ANA Charging System logo | 33 | Ground Wire Location |
| 16 | Airman logo | 34 | Warning - Arc Flash - PPE |
| 17 | Warning - Wheels & Lugnuts | 35 | ANA Energy logo |
| 18 | Journey to Zero logo | | |

▶ EBOSS™ Decals

EBOSS™ 220kVA hybrid decals.

1



2

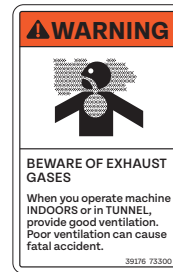

3

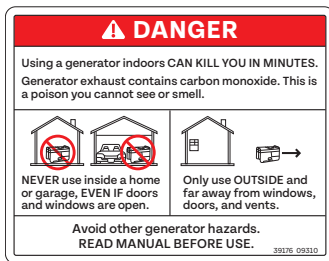

4

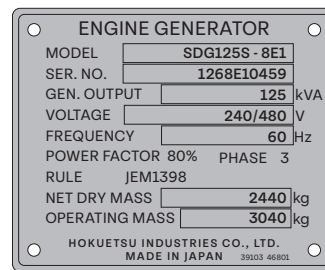

5

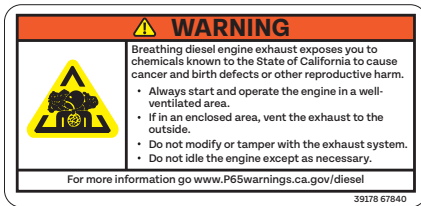

6



7



8

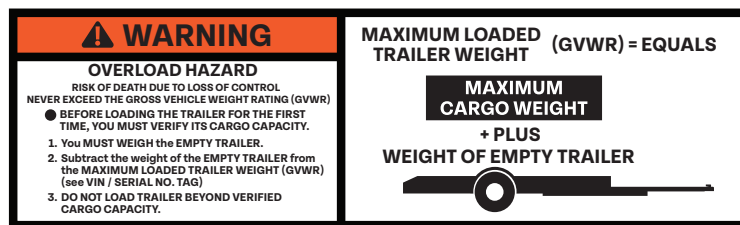

▶ EBOSS™ Decals

EBOSS™ 220kVA hybrid decals.

9

| | | | |
|--|---|---|---|
| CAUTION | OPERATOR RESPONSIBILITY SAFE TRAILER TOWING GUIDELINES: | WARNING | NOT FOLLOWING THESE SAFE TRAILER GUIDELINES CAN LEAD TO SERIOUS INJURY OR DEATH AND/OR PROPERTY DAMAGE. |
| <ul style="list-style-type: none"> ■ BEFORE TOWING CHECK COUPLING, SAFETY CHAIN, SAFETY BRAKE, TIRE INFLATION, WHEELS AND LIGHTS. ■ USING A SPOTTER, BACK TOW VEHICLE UP TO TRAILER AND HOOK UP. ■ AFTER CONNECTED TO TOW VEHICLE, MAKE SURE TRAILER IS LEVEL; ADJUST AS NEEDED. ■ LOCK PARKING BRAKE OF TOW VEHICLE, BE SURE TRAILER IS ATTACHED, & USE WHEEL CHOCKS WHEN LOADING & UNLOADING. ■ NEVER LEAVE TRAILER DISENGAGED FROM TOW VEHICLE WHEN LOADED. ■ MAKE SURE DECK IS CLEAR OF ALL DEBRIS BEFORE LOADING AND BEFORE HEADING OUT ONTO THE ROAD. ■ SECURE CARGO OR EQUIPMENT TO TRAILER; SECURE LOAD ON ALL FOUR CORNERS IF POSSIBLE. DO NOT OVER TIGHTEN BINDERS. ■ RAMPS MUST BE UPRIGHT & SECURE DURING TOWING. DO NOT PUT HANDS & FEET UNDER RAMPS OR GATE WHEN RAISING OR LOWERING. ■ RAMPS / GATES / DECK HAVE SLIPPERY SURFACES; USE EXTREME CAUTION IN WET OR MOIST CONDITIONS. ■ ADJUST BRAKE CONTROLLER TO ENGAGE THE TRAILER BRAKES BEFORE THE TOW VEHICLE BRAKES. YOUR DEALER CAN ASSIST YOU BY MAKING THIS ADJUSTMENT. ■ USE YOUR TURN SIGNALS WELL IN ADVANCE. ■ USE YOUR MIRRORS TO VERIFY THAT YOU HAVE ROOM TO CHANGE LANES OR PULL INTO TRAFFIC, OR IF VISION IS OBSTRUCTED. ■ ALLOW PLENTY OF ROOM FOR PASSING. THE PASSING DISTANCE WITH A TRAILER IS 4 TIMES THE PASSING DISTANCE WITHOUT A TRAILER. ■ ALLOW PLENTY OF STOPPING SPACE FOR YOUR TRAILER AND TOW VEHICLE. ■ NEVER DRIVE FASTER THAN 50 MPH. | <ul style="list-style-type: none"> ■ DO NOT DRIVE SO FAST THAT THE TRAILER BEGINS TO SWAY DUE TO SPEED. ■ SHIFT YOUR AUTOMATIC TRANSMISSION INTO A LOWER GEAR FOR CITY DRIVING. ■ USE LOWER GEARS FOR CLIMBING AND DESCENDING GRADES. ■ DO NOT RIDE THE BRAKES WHILE DESCENDING GRADES; THEY MAY GET SO HOT THAT THE STOP WORKING. THEN YOU WILL POTENTIALLY HAVE A RUNAWAY TOW VEHICLE AND TRAILER. ■ SLOW DOWN FOR BUMPS IN THE ROAD. TAKE YOUR FOOT OFF THE BRAKE WHEN CROSSING THE BUMP. ■ DO NOT BRAKE WHILE IN A CURVE UNLESS ABSOLUTELY NECESSARY. INSTEAD, SLOW DOWN BEFORE YOU ENTER THE CURVE AND POWER THROUGH THE CURVE THIS WAY THE TOWING VEHICLE REMAINS IN CHARGE. ■ DO NOT APPLY THE BRAKES TO CORRECT EXTREME TRAILER SWAYING; STEER STRAIGHT AHEAD AND REMOVE YOUR FOOT FROM THE GAS. | ONCE EACH HOUR OR EVERY 50 MILES CONFIRM THAT <ul style="list-style-type: none"> ■ THE COUPLER IS SECURE TO THE HITCH AND IS LOCKED. ■ ELECTRICAL CONNECTIONS ARE SECURE. ■ THERE IS APPROPRIATE SLACK IN BOTH THE SAFETY CHAINS, AND THE BREAKAWAY SWITCH PULL PIN CABLE. ■ THE TIRES ARE NOT VISIBLY LOW ON PRESSURE, AND THE CARGO IS SECURE AND IN GOOD CONDITION. | |

10



11



12

SDG125

13

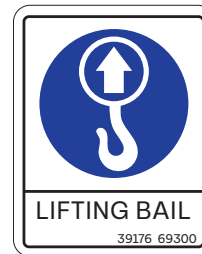

14



15



▶ EBOSS™ Decals

EBOSS™ 220kVA hybrid decals.

16

AIRMAN

17

⚠ WARNING

Tire, wheel or lugnut failure can cause loss of control. Before towing, you must CHECK:

1. Tire pressure and tread.
2. Tires and wheels for damage.
3. Lug nuts for tightness.

For new and remounted wheels, re-tighten lug nuts at the first 10, 25 and 50 miles of driving.



Lug Nuts TIGHT?

Tires and Wheels OK?

© 2002 NATM T0012

18

JOURNEY TO ZERO

19

EBOSS™

220kVA

- POWER MODULE -

20

QUICK START GUIDE

START UP PROCEDURE

- 1.) Before starting the Energy Boss, ground the Energy Boss, then ground the generator (see the generator manual for directions).
- 2.) On the generator, turn the control power switch ON.
- 3.) Place generator into Auto Mode.
- 4.) Make sure the voltage selector is set to 480V.
- 5.) Connect the 3 Orange Battery Disconnects (located directly on the battery packs beneath the unit) by twisting clockwise. (See Energy Boss manual for more information.)
- 6.) Switch the main generator breaker to ON.
- 7.) On the Energy Boss, firmly press the black button under the HMI control screen. The system will take around 30 seconds to power up.
- 8.) Connect load to correct voltage outputs and turn ON breakers for that load. Breakers on unused outlets should be OFF.
- 9.) Push the START button on the touch screen.
- 10.) Check output voltages and adjust voltage as needed.

SHUT DOWN PROCEDURE

- 1.) Press STOP button on Energy Boss to stop the power output.
- 2.) Turn OFF the output breaker located within the breaker panel.
- 3.) To manually shut down, press FAULTS then press SHUT DOWN. The Control Screen will shut down automatically when the battery reaches 35%.
- 4.) On the generator, turn OFF the main breaker.
- 5.) On the generator, switch control power to OFF.

LONG TERM STORAGE PROCEDURE

- 1.) Ensure the battery is at least 95% charged.
- 2.) Disconnect the 3 Orange Battery Disconnects (located directly on the battery packs beneath the unit) by twisting counterclockwise and pulling out. (See Energy Boss manual for more information.)

3000000178

21

DANGER

HIGH VOLTAGE

22

Never Exceed the Maximum Combined Simultaneous Power Consumption

The following chart shows the maximum power available from the 120V-20A GFCI receptacles during simultaneous consumption (main terminals and receptacles) for both single or three phase settings. Values shown in the left column give the maximum current available at the 120V-20A GFCI receptacles compared to the value of the simultaneous current consumption from the main terminals.

| Single Phase 120V-20A GFCI Recept. | SDG125 | | SDG150 | |
|--|-------------------------|-------------------------|-------------------------|-------------------------|
| | Three Phase 240/480V | Three Phase 240/480V | Three Phase 240/480V | Three Phase 240/480V |
| | kW | kVA | kW | kVA |
| 0.0 | 125 | 72.0 | 150 | 87.0 |
| 1.2 | 121 | 70.8 | 146 | 85.8 |
| 2.4 | 117 | 69.6 | 142 | 84.6 |
| 3.6 | 113 | 68.4 | 138 | 83.4 |
| 4.8 | 108 | 67.2 | 133 | 82.2 |

39176 89700

23

⚠ DANGER

DO NOT OPEN PANEL WHILE
UNIT IS RUNNING

HIGH VOLTAGE

30235 02400

▶ EBOSS™ Decals

EBOSS™ 220kVA hybrid decals.

24

WARNING

Do not touch live electrical parts.
Always wear dry insulating gloves.
Do not operate the unit in the rain, around standing water or when wet.
Maintain all electrical cords and connections in proper condition.
Always ground the generator to earth before operating.

39176 62900

25

CAUTION!

Power distribution and cable route to main terminal connections located under panel.

39176 65800

26

TIRE AND LOADING INFORMATION
RENSEIGNEMENTS SUR LES PNEUS ET LE CHARGEMENT

The weight of cargo should never exceed 2,268 kg or 5,000 lbs.

| TIRE | SIZE | COLD TIRE PRESS. | SEE OWNER'S MANUAL FOR ADDITIONAL INFORMATION |
|-------|---------------|------------------|--|
| FRONT | ST235/80R-16E | 552 KPA (80 PSI) | VOIR LE MANUEL DE L'USAGER POUR PLUS DE RENSEIGNEMENTS |
| INTER | ST235/80R-16E | 552 KPA (80 PSI) | |
| REAR | ST235/80R-16E | 552 KPA (80 PSI) | |
| SPARE | NONE | NONE | |

7H6BX22C5RH001699

27

MANUFACTURED BY: ALLIANCE NORTH AMERICA, INC.

DATE OF MFG : 10/2024 GVWR: 9525 KG (21000 LB)

| GAWR (EACH AXLE) | WITH TIRES | RIMS AT | COLD |
|-------------------|---------------|----------|-----------------------|
| 3175 KG (7000 LB) | ST235/80/16 E | 16" X 6" | 552 KPA (80 PSI) DUAL |

THIS VEHICLE CONFORMS TO ALL APPLICABLE U.S. FEDERAL MOTOR VEHICLE SAFETY STANDARDS IN EFFECT ON THE DATE OF MANUFACTURE SHOWN ABOVE

V.I.N. : 7H6BX22C5RH001699 TYPE: TRAILER

MODEL: BOSS220-125

28

DANGER

SERIOUS INJURY AND/OR PROPERTY DAMAGE CAN RESULT IF THIS VEHICLE IS TOWED BEFORE FAMILIARIZING YOURSELF WITH THE MANUFACTURER'S OPERATING INSTRUCTIONS AND CAUTIONS LISTED TO THE RIGHT.

CAUTION

BEFORE TOWING THIS TRAILER CHECK THAT:

- COUPLER HITCH AND TRAILER BALL ARE THE SAME SIZE.
- COUPLER IS LATCHED.
- SAFETY CHAINS ARE CRISSCROSSED UNDER TONGUE AND ATTACHED TO TOWING VEHICLE.
- ALL TRAILER LIGHTING IS WORKING CORRECTLY.
- LOAD IS SECURED TO TRAILER FRONT AND REAR.
- TONGUE JACK (IF TRAILER IS EQUIPPED) IS RETRACTED.
- TILT PIN IS LATCHED.
- WHEEL LUG BOLTS ARE PROPERLY TIGHTENED.
- TIRES ARE INFLATED TO PRESSURE INDICATED ON TIRE.
- TRAILER BRAKES (IF TRAILER IS EQUIPPED) ARE PROPERLY ADJUSTED AND BREAK-AWAY DEVICE IS ATTACHED TO TOWING VEHICLE.
- LOAD IS WITHIN TRAILER CAPACITY AND DISTRIBUTED PROPERLY TO MAINTAIN PROPER TONGUE WEIGHT.

WARNING

YOU ARE REQUIRED TO COMPLY WITH LOCAL AND STATE REQUIREMENTS REGARDING BRAKES, LICENSING AND ANY ADDITIONAL EQUIPMENT THAT MAY BE NECESSARY. CONTACT YOUR STATE MOTOR VEHICLE DEPARTMENT FOR MORE INFORMATION.





29

| WARNING | WARNING | WARNING | WARNING |
|--|--|--|--|
| <p>Uncoupling will cause trailer to come loose from tow vehicle.</p> <p>1. CHECK that pin's LOAD RATING is same or greater than ring LOAD RATING.</p> <p>2. LOCK the clamp on place using a pin or lock.</p> | <p>ALWAYS use safety chains. Chains hold trailer if connection fails. You must:</p> <ol style="list-style-type: none"> 1. CROSS chains underneath coupler. 2. ALLOW slack for trailer to turn. 3. ATTACH chain hooks securely to tow vehicle frame. | <p>Trailer can roll if it comes loose. Electric safety brake applies when cable pulls pin out of switch box:</p> <ol style="list-style-type: none"> 1. PULL hard to get pin out of switch box. 2. CHECK brake by PULLING TRAILER with tow vehicle. 3. ATTACH pin CABLE to tow vehicle so pin will be pulled out if trailer separates. 4. Promptly REPLACE pin in switch box. | <p>Lights can prevent trailer from being hit by other vehicles. You must:</p> <ol style="list-style-type: none"> 1. CONNECT trailer and tow vehicle electrical connectors. 2. CHECK all lights: tail lights, turn signals, and brake lights. 3. DO NOT TOW if lights are not working. |
| <p>Open clamp</p> <p>Pin in place</p> <p>Pin removed</p> <p>Closed clamp</p> | <p>ATTACH TO TOW VEHICLE FRAME</p> <p>CROSS CHAINS</p> <p>ENOUGH SLACK FOR TURNS</p> | <p>PIN PULLED ONLY TO TEST BRAKES</p> <p>SWITCH BOX</p> <p>TRAILER SAFETY BRAKE</p> <p>ATTACH CABLE TO TOW VEHICLE</p> | <p>DISCONNECTED</p> <p>CONNECTED</p> <p>K003</p> |

▶ EBOSS™ Decals

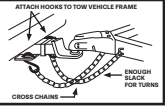
EBOSS™ 220kVA hybrid decals.

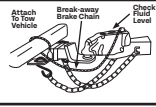
30

| ⚠ WARNING | | ⚠ WARNING | | ⚠ WARNING | | ⚠ WARNING | |
|--|--|--|--|--|--|--|--|
| <p>ALWAYS use safety chains. Chains hold trailer if connection fails. You must:</p> <ol style="list-style-type: none"> CROSS chains underneath coupler. ALLOW slack for trailer to turn. ATTACH chain hooks securely to tow vehicle frame. | | <p>Uncoupling will cause trailer to come loose from tow vehicle. You must:</p> <ol style="list-style-type: none"> CHECK that ball LOAD RATING is same or greater than coupler LOAD RATING. CHECK that ball SIZE is same as coupler. CLOSE COUPLER CLAMP on ball. LIFT coupler upwards to test that it will not separate from ball. LOCK coupler clamp with pin or padlock. | | <p>Trailer can roll if it comes loose. Safety brake applies when chain pulls brake lever:</p> <ol style="list-style-type: none"> ATTACH brake CHAIN to tow vehicle so lever will pull out if trailer separates. CHECK brake fluid level. DO NOT TOW trailer if brake fluid level is NOT FULL. | | <p>Lights can prevent trailer from being hit by other vehicles. You must:</p> <ol style="list-style-type: none"> CONNECT trailer and tow vehicle electrical connectors. CHECK all lights: tail lights, turn signal, and brake lights. DO NOT TOW if lights are not working. | |
| <p>ATTACH HOOKS TO TOW VEHICLE FRAME</p>  <p>CROSS CHAINS</p> <p>ENOUGH SLACK FOR TURN</p> | | <p>Open clamp</p>  <p>Closed clamp</p>  <p>Pin or padlock in place</p> <p>Lift coupler to check</p> | | <p>Attach to Tow Vehicle</p>  <p>Break-away Brake Chain</p> <p>Check Fluid Level</p> | | <p>DISCONNECTED</p>  <p>CONNECTED</p>  <p>K004</p> | |

31



32



33



34



35



► Safety - Explanations and Symbols

Read this manual thoroughly and make sure you understand the procedures before you attempt to install, set up, or operate the ANA EBOSS™. Operating and servicing any part of the EBOSS™ requires Personal Protective Equipment (PPE) such as High Voltage gloves rated up to 1000V, Protective Eyewear, and Non Conductive Shoes. Do not touch anything without confirming with a Voltmeter the unit is safe to touch.

Warning - Hazardous High Voltage



Motor control equipment and electronic controllers are connected to hazardous line voltages. When servicing drives and electronic controllers, there may be exposed components with housings or protrusions at or above line potential. Extreme care should be taken to protect against shock.

Warning - Hazardous High Voltage



- Stand on an insulating pad and make it a habit to use only one hand when checking components.
- Always work with another person in case an emergency occurs.
- Disconnect power before checking controllers or performing maintenance.
- Be sure equipment is properly grounded.
- Wear safety glasses whenever working on electronic controllers or rotating machinery.

Warning - Hazardous High Voltage



Be sure to ground the unit following the instructions in this manual. Ungrounded units may cause electric shock and/or fire.

Warning - Hazardous High Voltage



This equipment should be installed, adjusted, and serviced by qualified electrical maintenance personnel familiar with the construction and operation of this type of equipment and the hazards involved. Failure to observe this precaution could result in death or severe injury.

Warning - Hazardous High Voltage



An upstream disconnect/protective device must be provided as required by the National Electric Code (NEC). Failure to follow this precaution may result in death or severe injury.

Caution - Equipment Damage



Any electrical or mechanical modification to this equipment without prior written consent of ANA will void all warranties and may result in a safety hazard and voiding of the UL listing.

Caution - Equipment Damage



Inside the EBOSS™ enclosure, **BEFORE CONNECTING POWER**, ensure that all DC power connections, communication cables, and control wires are connected. Connecting any of these cables or wires while the system is powered may result in an electrostatic discharge or an initial over current which can result in damage of electrical components.

Never connect and/or disconnect power to any component on the DC power circuit with the DC power supply's 120VAC supply powered on. Turn off power to the power supply before connecting and/or disconnecting any component on the DC circuit.

Caution - Equipment Damage



Do not perform any meggar or voltage withstand tests on any part of the SBP Drive or its components. Improper testing may result in damage.

Caution - Equipment Damage



Prior to any tests or measurements of the motor or the motor cable, disconnect the motor cable at the SBP output terminals (U, V, W) to avoid damaging the SBP during motor or cable testing.

Caution - Equipment Damage



Do not touch any components on the circuit boards. Static voltage discharge may damage the components.

Caution - Equipment Damage



Prevent foreign material such as wire clippings or metal shavings from entering the drive or controller enclosure, as this may cause arcing damage and fire.

Caution - Equipment Damage



Before starting the motor, check that the motor is mounted properly and aligned with the driven equipment. Ensure that starting the motor will not cause personal injury or damage equipment connected to the motor.

Caution - Equipment Damage



Before reversing the motor rotation direction, ensure that this will not cause personal injury or equipment damage.

► Definitions and Acronyms

The following terms and acronyms are used throughout this manual to describe the functions and operation of the EBOSS™. Please reference this page if you need any clarification as you read through this operation manual.

SOC - State of Charge.

DC - Direct Current.

Converter - Rectifier circuit used to convert AC to DC. The DC from the converter is called the DC bus voltage.

DC Bus - Resulting voltage in the circuit from the converted AC voltage after the rectifier circuitry.

IGBT - Insulated Gate Bipolar Transistor.

Inverter - IGBT circuit configured to change DC bus voltage to AC of varying frequencies through pulse width modulation (PWM).

PWM - Pulse Width Modulation.

Battery Storage System - Group of batteries used to store the required amount of voltage (energy) for operation of the EBOSS™.

Generator - Converts motive power into electrical power for use in an external circuit via diesel motor.

HMI - Human Machine Interface, control screen.

Telematics - Telematics is a system of software and hardware elements that allows:

- Control industrial processes locally or at remote locations.
- Monitor, gather, and process real-time data.
- Directly interact with devices such as sensors, valves, pumps, and motors through human-machine interface (HMI) software.

▶ **Transportation on a Flatbed**

EBOSS™ must be loaded or unloaded using the correct equipment operated by trained personnel. ANA offers no direct support for untrained individuals carrying out any action on the unit. The unit must remain upright at all times. Contact ANA Support to request training.

Warning - Equipment Damage



- The EBOSS™ can be transported using a trailer or goods vehicle with adequate available payload. Check the relevant transportation documentation for suitability.
- The gross weight of the unit can be found on the rating plate positioned on the central front door.
- It is recommended that the unit is secured using suitable straps when in transit to prevent it from moving.
- Unit must be switched off through the EBOSS™ HMI System switch button on home tab.
- Check that the emergency stop button is not engaged by twisting it clockwise.

▶ **Loading and Unloading**

The EBOSS™ weighs over 16,000 lbs with fuel and accessories. A forklift or crane with the proper lift capacity is required to safely load or unload the EBOSS™.

Once loaded on a flat bed trailer, utilize the 4 tie downs on the underside of the trailer frame to secure the EBOSS™ to the trailer.

► Overhead Lifting - Anchor Points

The EBOSS™ may be lifted using an appropriately rated crane and rigging connected to the anchor point on the generator and the 2 rigging points located at the rear. Initially, apply partial load and check for proper rotation and alignment.

Never use an anchor or rigging point that shows signs of corrosion, wear or damage. Never use an anchor or rigging point if it appears to be bent or elongated.

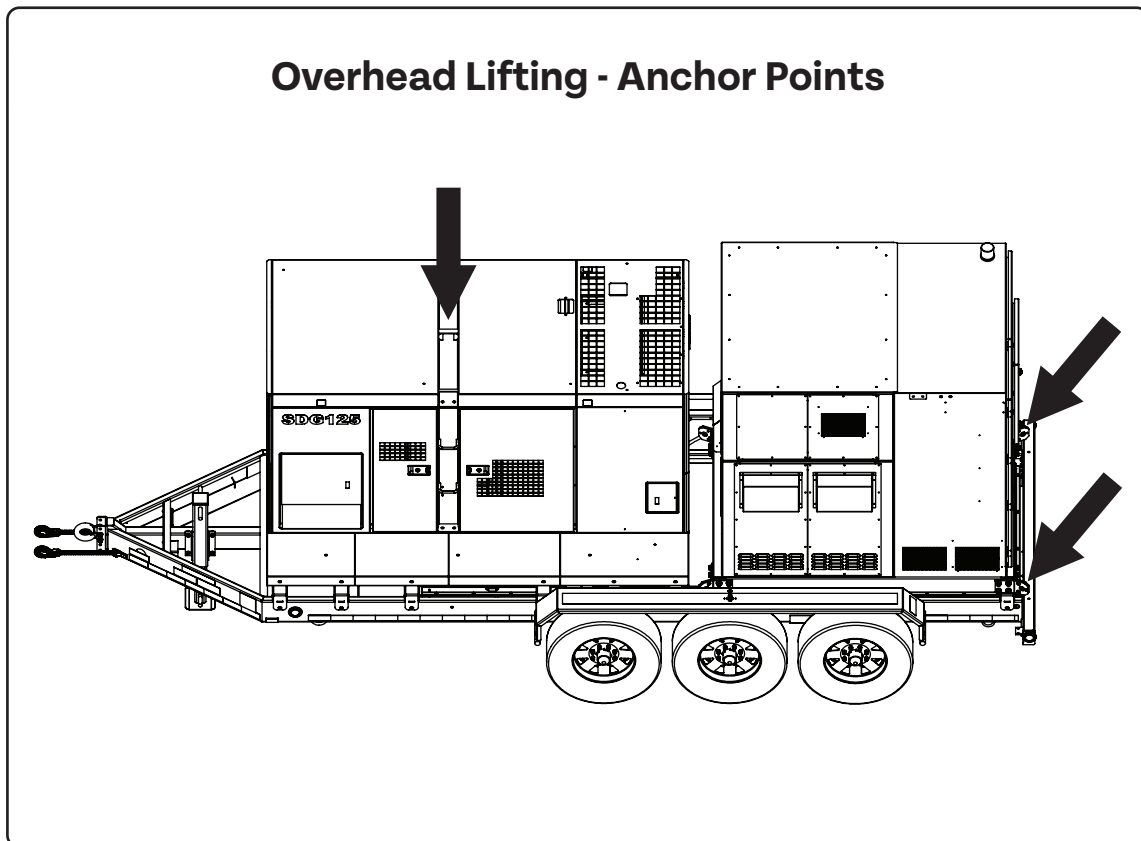

► Lifting Locations - Forklift

Fork lift locations are located behind the rear axle and in front of the front axle for balanced lifting.

► Unloading

1) Remove tiedowns or chains securing the EBOSS™ to the flatbed trailer. Carefully approach the EBOSS™ with a properly rated forklift with a pintle hitch attachment.



2) Position the pintle hitch attachment to connect to the EBOSS™ trailer. Slowly raise the forks to level out the EBOSS™. Carefully begin backing the EBOSS™ off of the flatbed trailer.



► Unloading (cont)

3) Slowly back the EBOSS™ off of the flatbed trailer, being careful to keep the load centered on the trailer and ramps. Be aware of your surroundings and use a spotter if available to assist you.



4) Back the EBOSS™ completely away from the flatbed trailer. Engage the trailer jacks into an upright position and lower the forks to set the EBOSS™ on the ground. Disconnect the pintle hitch.



▶ Loading

1) Disconnect the tow rig from the trailer (depending on your truck and trailer configuration). Position boards or low rise ramps as needed for the EBOSS™ to load onto the flatbed trailer.



2) Position the pintle hitch attachment to connect to the EBOSS™ trailer. Slowly raise the forks to level out the EBOSS™. Carefully begin approaching the flatbed trailer with the EBOSS™.



▶ Loading (cont)

3) Slowly load the EBOSS™ onto the flatbed trailer, being careful to keep the load centered on the trailer and ramps. Be aware of your surroundings and use a spotter if available to assist you.



4) Carefully lower the forks, positioning the EBOSS™ onto the flatbed trailer. Disconnect the pintle hitch and slowly back the forklift away from the trailer. Attach rigging required to secure the load.



► Securing to a Flatbed

Once the EBOSS™ has been loaded on a flat bed, utilize the 4 tie downs on the underside of the trailer frame to secure the EBOSS™ to the flat bed trailer.

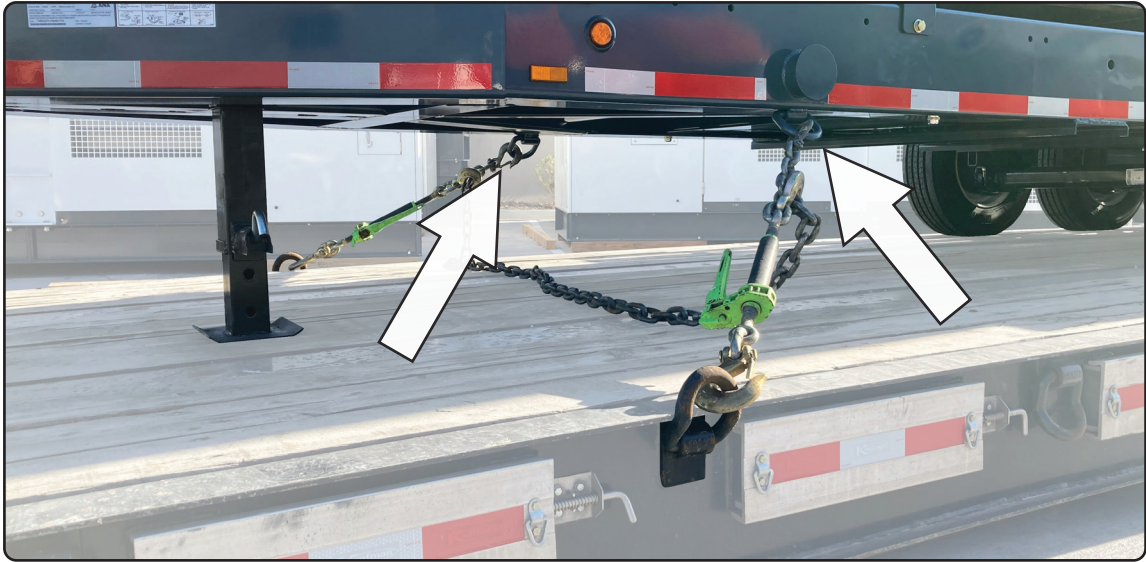

Tie down locations are located in front of the front axles (2) and behind the rear axles (2). These are designed for tie down only and are not designed for lifting the EBOSS™.



► Tie Down Locations

There are 4 tie down locations on the EBOSS™. These tie down locations are designed to secure the EBOSS™ to a flatbed trailer for transport only.

Do not use these tie down locations to lift, tow, reposition, or otherwise move the EBOSS™. These tie down locations are not designed to withstand vertical or horizontal forces beyond securing the EBOSS™ to a flatbed trailer for transport.



▶ Towing the EBOSS™

The EBOSS™ can be towed using a properly rated tow vehicle. With the EBOSS™ weighing more than 16,000 lbs, the driver of the tow vehicle should be familiar with towing heavy loads.



Warning - Equipment Damage



- The EBOSS™ can be transported using a vehicle with adequate available towing capacity. Check the tow vehicle's owners manual or tow rating for the correct information.
- The gross weight of the unit can be found on the rating plate positioned on the central front door.
- Unit must be switched off through the EBOSS™ HMI System switch button on home tab.
- Check that the emergency stop button is not engaged by twisting it clockwise.

▶ Attaching the Hitch

The EBOSS™ can be towed with a properly rated vehicle that has a correctly installed pintle hitch and lunette ring connections.



Attach the Pintle Hitch

- 1)** Using the trailer jack, raise the lunette ring coupler high enough to clear the pintle hitch on the tow vehicle.
- 2)** Remove the locking pin and lift the pintle hitch latch. Back up the tow vehicle (use a spotter if available) to position the pintle hitch directly under the lunette ring.
- 3)** Using the trailer jack, lower the trailer and lunette ring coupler onto the pintle hitch hook on the tow vehicle. Close and lock the pintle hitch latch and insert the latch pin.
- 4)** Fully retract the trailer jack. Attach tow chains to the tow vehicle.
- 5)** Connect the trailer wiring connector and emergency brake cable to the tow vehicle.
- 6)** Check the trailer brake lights and running lights for proper operation and visibility.

► Inspecting the Trailer and Tow Vehicle

The EBOSS™ trailer and tow vehicle should be thoroughly inspected before every trip.



Pre-Trip Inspection Checklist

- 1) Check the trailer has been attached correctly and the running and brake lights are operating properly and visible.
- 2) Ensure the trailer tires are properly inflated and have sufficient tread depth, and the trailer wheels are torqued to the correct values.
- 3) Check that the trailer has the correct license plate, registration, and proper DOT documentation.
- 4) Check that the tow vehicle is in good condition (especially tires and brakes) and is properly equipped to tow the EBOSS™.

Safe Towing Guidelines

- 1) Do not exceed 55mph when towing on paved roads or 15mph on unpaved roads.
- 2) Drive cautiously and reduce travel speed in order to travel, turn, and stop safely.

► Fueling and Grounding

Fill the fuel tank on the generator before initial start-up. Ensure the generator is properly grounded per the manufacturer's operation manual instructions.



Ensure that the generator is grounded to specifications outlined in the generator's user manual. Failure to properly ground the generator may result in damage to the EBOSS™ and poses a safety risk to users.

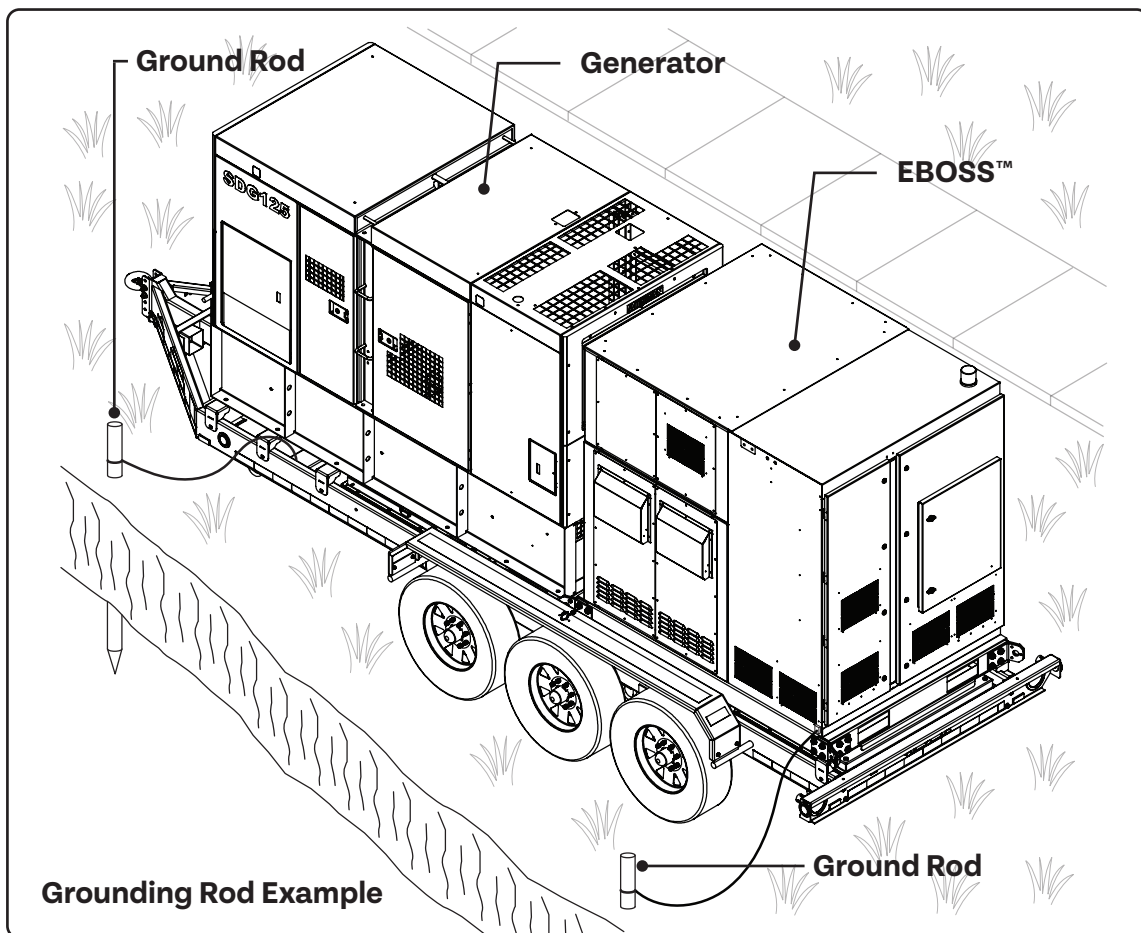

▶ Setup for Operation

The EBOSS™ is a Hybrid Energy System that combines a Generator with an Energy Storage system that maximizes the use of fuel and reduces generator run time. The system only runs the generator at full load when charging the EBOSS™, which is the most efficient use of the generator in terms of gallons per kW.

The home screen (HMI) shows the direction of power flow. The EBOSS™ uses three inverters to route power between the generator, the battery storage system, and the loads.

Generator Inverter - Takes the power from the generator and converts the load to DC Bus.

Grid Converter - Inverts the DC Bus to usable power to the grid.

DC/DC Inverter - Takes voltage from the DC Bus to charge the battery storage system.

Charging the EBOSS™

The generator charges the EBOSS™ battery. Once the battery is fully charged, the generator shuts off.

Powering the Load

The stored energy in the battery provides power to the load. Once the battery discharges to 15% capacity, the generator starts up again to charge the battery.

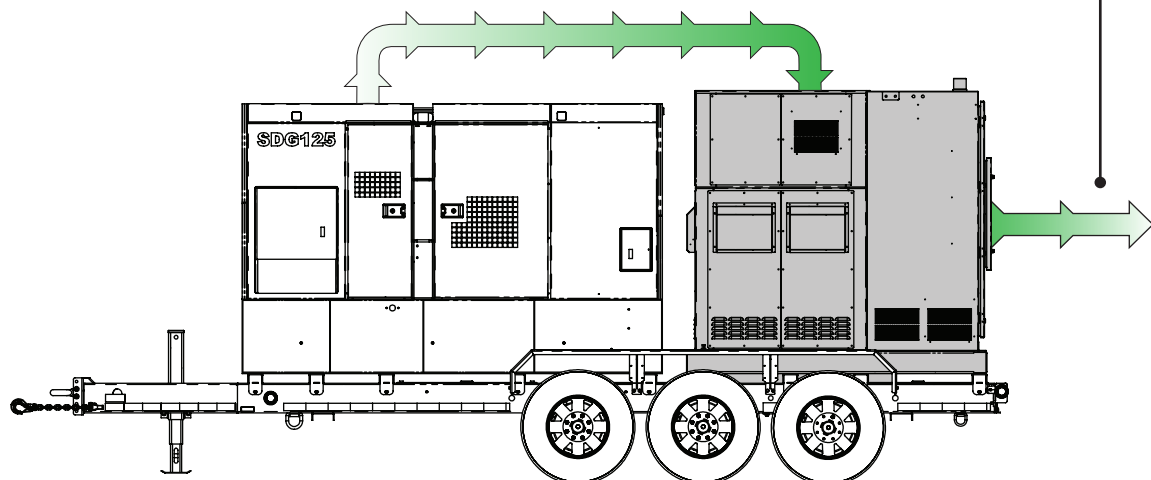

▶ **Start Up Procedure**

- 1) Before starting the EBOSS™, ground the generator.
- 2) On generator, turn control power switch to “**ON.**”
- 3) Press “**AUTO**” button to place generator in auto mode.
- 4) Adjust voltage selector to 480V if needed.
- 5) Switch main generator breaker to “**ON.**”
- 6) On EBOSS™, push and hold down black button under control screen until screen fully turns on (up to 30 seconds).
- 7) Turn on the main breaker located on the side door (street side).
- 8) Connect load to correct voltage outlets and turn on breakers for that load. Breakers on unused outlets should be off.
- 9) Push the “**START**” button on the touch screen.
- 10) Check output voltages, “adjust voltage” as needed.

▶ **Shut Down Procedure**

- 1) Press “**STOP**” button on the touch screen to shut power down.
- 2) Turn off the main breaker located on the side door (street side).
- 3) Control screen remains on to allow battery monitoring.
- 4) On the generator, turn the control power switch to “**OFF.**”

▶ Power Sources

The EBOSS™ has the following power connection options:

- 3-Phase 480V (2 - connections, Cam Loks)
- 3-Phase 208V (2 - connections, Cam Loks)
- Single Phase 120V (1 - outlet connection)



The combined output of each leg at 480V is 58kW. Thus, ensure legs are balanced as much as possible to ensure reliable operation. Connecting 3 phase power to a spider box panel and multiple spider boxes can isolate one of the legs and cause one of the legs to be over the 58kW limit.



▶ Batteries

The ANA lithium battery system is a high power, ultra-high cycle life system built for a wide number of commercial and industrial applications. Operation of the battery is fully automated and it shouldn't require any maintenance or servicing.

| EBOSS™ 220kVA Battery Specs | |
|-----------------------------|------------------------|
| Energy Rating | 75 kWh |
| Max Voltage | 648 V |
| Min Voltage | 360 V |
| Typical High Voltage | 610 V |
| Typical Low Voltage | 415 V |
| Chemistry | Lithium Titanate Oxide |

All lithium-ion batteries are susceptible to fluctuations in temperature, but the ANA battery system used in this application is much less sensitive than other batteries. Standard operating temperature range is -30°C to 55°C (-22°F to 130°F).

The batteries always have live voltage. A service disconnect is used in the system in order to provide a means of disconnection in the middle of the battery pack string. This means that, when disconnected, positive and negative high voltage battery leads are not in electrical continuity with each other.



Completely turning off the EBOSS™ and generator is required before removing the service disconnect. Ensure the service disconnect is twisted off completely and placed away from the mating connector to avoid making contact.

▶ Operation Sequence

EBOSS™ Sequence of Operation

- 1)** After starting up the generator (unit is fueled and properly grounded, voltage set to 480V, and load has been connected), the EBOSS™ is now ready to operate.
- 2)** On the EBOSS™, push and hold down black button under control screen until screen fully turns on (up to 30 seconds).
- 3)** Press the green start button on the home screen to open a pop-up window that asks you to confirm you have read the manual and are ready to start the EBOSS™.
- 4)** After confirmation you want to start, the system will come online. This takes approximately 2 minutes for the output panel to be live and have power. The generator will start up and begin to charge the batteries to the max voltage while powering the output load.
- 5)** Close breakers on any unused outputs.
- 6)** Once the battery is fully charged, the generator will shut off.
- 7)** The batteries will carry the electrical load until the batteries deplete. When this happens, the EBOSS™ will then send a command to start the generator and repeat the cycle.
- 8)** When the red stop button is pressed, output power stops and all contactors are open. At this time the generator has a one minute cool down period before it shuts down. Do Not hit the E-Stop; allow the generator to cool down properly.
- 9)** The EBOSS™ will turn off by itself off when the battery's state of charge drops to about 35%.
- 10)** To manually turn off the EBOSS™, press the fault button on the main screen and the turn off button on the top right of the fault page.

EBOSS™ Sequence of Operation (cont)

11) Remember to also turn off the control switch on the generator and close the main breaker to prevent unnecessary battery drain on the generator.

▶ Cold Weather Operation

Important Notes

1) The EBOSS™ can operate at temperatures as low as -22°F (-30°C) as long as it is powering a load and the generator is equipped with a cold weather package. Operating temperature is much lower than the cold start temperature.

2) Once operational, the EBOSS™ storage system generates its own internal heat as it is charging and discharging the batteries, thus allowing a very low operating temperature.

3) It is recommended to install a cold weather package on the generator and EBOSS™ to ensure smooth and reliable operation in extreme cold temperatures. An optional cold weather package for the EBOSS™ includes a 1200W enclosure heater with built in thermostat during operation below 32°F (0°C).

4) The enclosure heater is designed to keep the EBOSS™ at a safe operating temperature in colder temperatures.



When temperatures are expected to be lower than -22°F (-30°C), it is recommended to keep the unit on and running with enclosure heater plugged in. With the enclosure heater installed, the EBOSS™ is rated for operation as low as -50°F (-45°C). A thermal blanket or cover may be installed over the EBOSS™ to allow for even colder temperatures.



Enclosure Heater Location

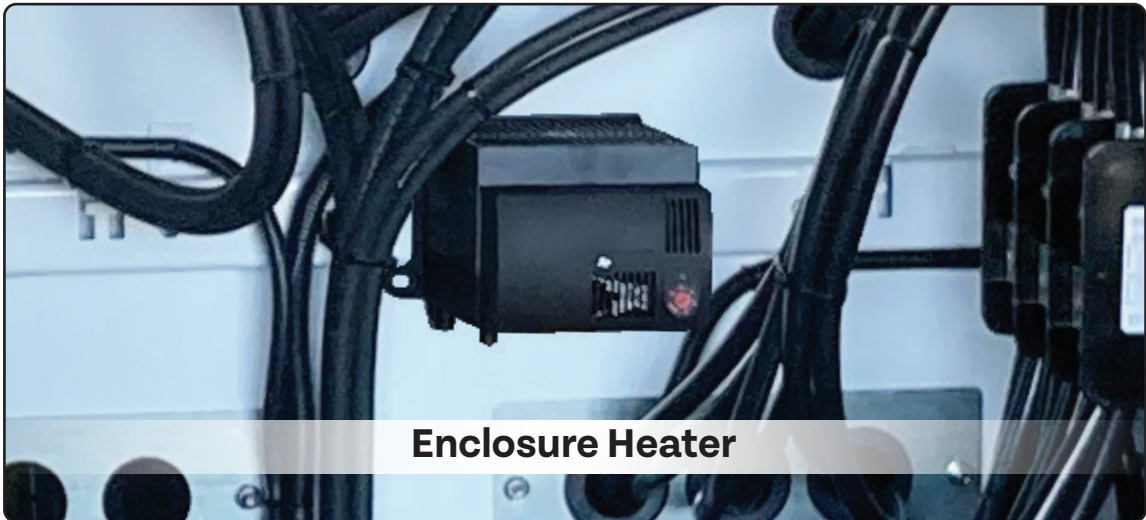

Enclosure Heater

▶ Cold Start Procedure

- 1)** The three inverters in the EBOSS™ must be above 14°F (-10°C) to start up and begin operation. This could take several minutes or hours to heat up on its own so it is recommended plug in the optional enclosure heater or use an external heater to get the inverter and enclosure components warm enough to start.
- 2)** Once the generator starts, either the generator or an external power source can be used as a source to plug in the enclosure heater or external heat source. The enclosure heater is connected to a flush mount 120V plug located on the front panel and clearly labeled when a cold weather kit is ordered with the EBOSS™.
- 3)** The batteries must be above -22°F (-30°C) in order for the EBOSS™ to charge the batteries. An electric heating blanket or blowing warm air onto the battery tray under the EBOSS™ can get the batteries up to temperature. Once operational, it should provide enough heat to continue operation without external aids.

▶ Parallel Mode Operation

The EBOSS™ uses a simple method of parallel mode, where no communication between units is required. The inverters mimic the physical properties of a traditional load sharing generator, using frequency droop to share the load across all units in parallel.

Set the unit to “parallel enabled” through the advanced settings. This sets the output voltage to a nominal 480V for all units. To ensure balanced load sharing, do not adjust this value from the nominal. The EBOSS™ can only parallel in 480V or 208V 3 phase. The system will not properly load share when paralleling other loads, although all voltages are available for power distribution while the EBOSS™ is in parallel.

▶ Parallel Mode Procedure

To put the units in parallel mode, click on the grid inverter on the HMI, and click on the parallel mode button. A gray button indicates the mode is enabled.

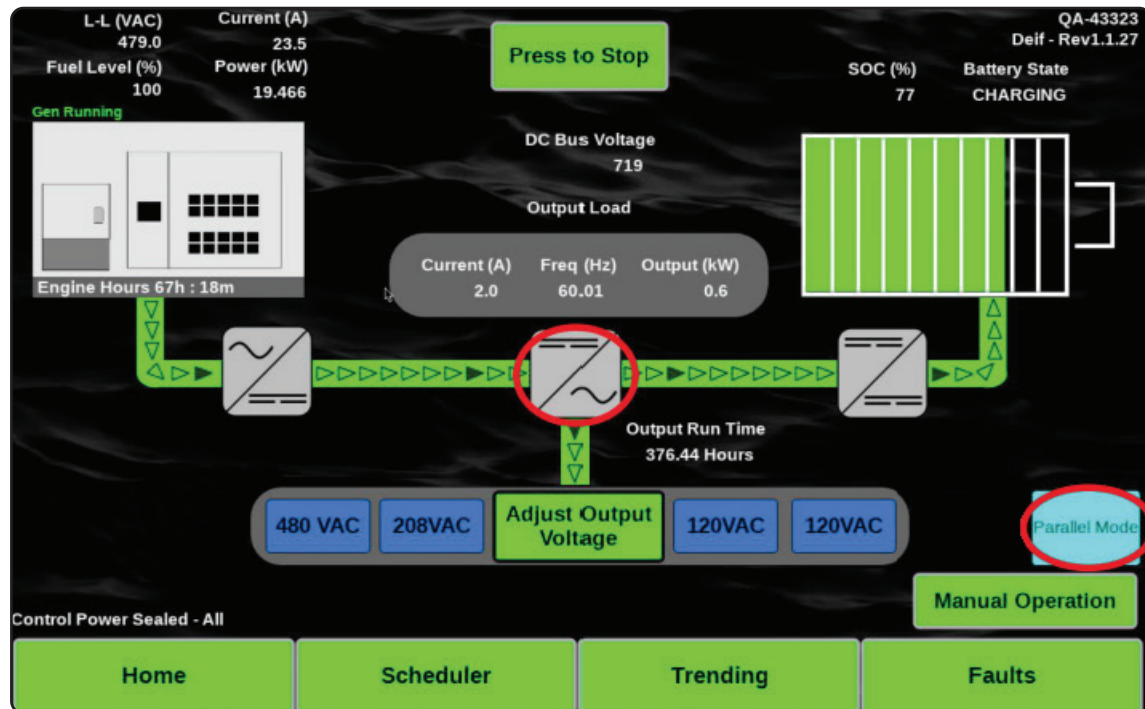

Allow all generators to fully charge batteries before attempting parallel connection to load.

After returning to the home screen, you will see a blue indicator with the label “parallel mode,” indicating that parallel mode has been successfully selected.

▶ **Parallel Mode Procedure (cont)**

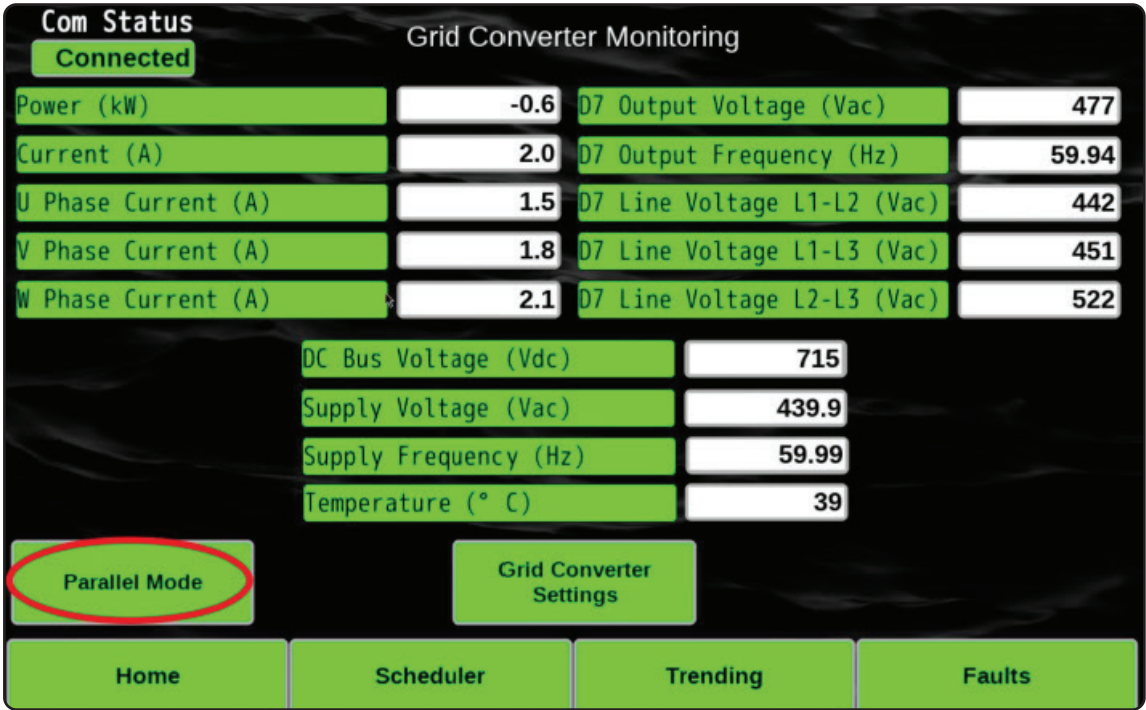

Once all units to be paralleled have the parallel selection set, start one of the units and enable the output, then bring all other units online (there is no number or timing sequence).

For head units, all A1 gen auto-start command connections are to be connected in parallel and tied to the X(A1) contact on the generator, and all head unit A2 wires are to be connected together and tied to the XX(A2) contact on the generator. Any unit calling for gen start will close this contact, triggering a gen start. All head units need to have their gen auto-start contacts opened in order to stop the gen from running.

The units should synchronize their charge requests to the generator within one or two full battery discharge/charge cycles. This is done through frequency droop, where units with a higher state of charge will allow a higher load draw and units with a lower state of charge will allow a lower load draw, until state of charges are similar on all units. (A majority of battery synchronization occurs during charge cycle.)

► HMI (Human Machine Interface) Display

Overview of the HMI Display

The Home screen of the HMI allows the user to operate the EBOSS™. The start button is red when the unit is off with the description “Press to Start”. When the start button is pressed the color turns green with the description “Press to Stop”.

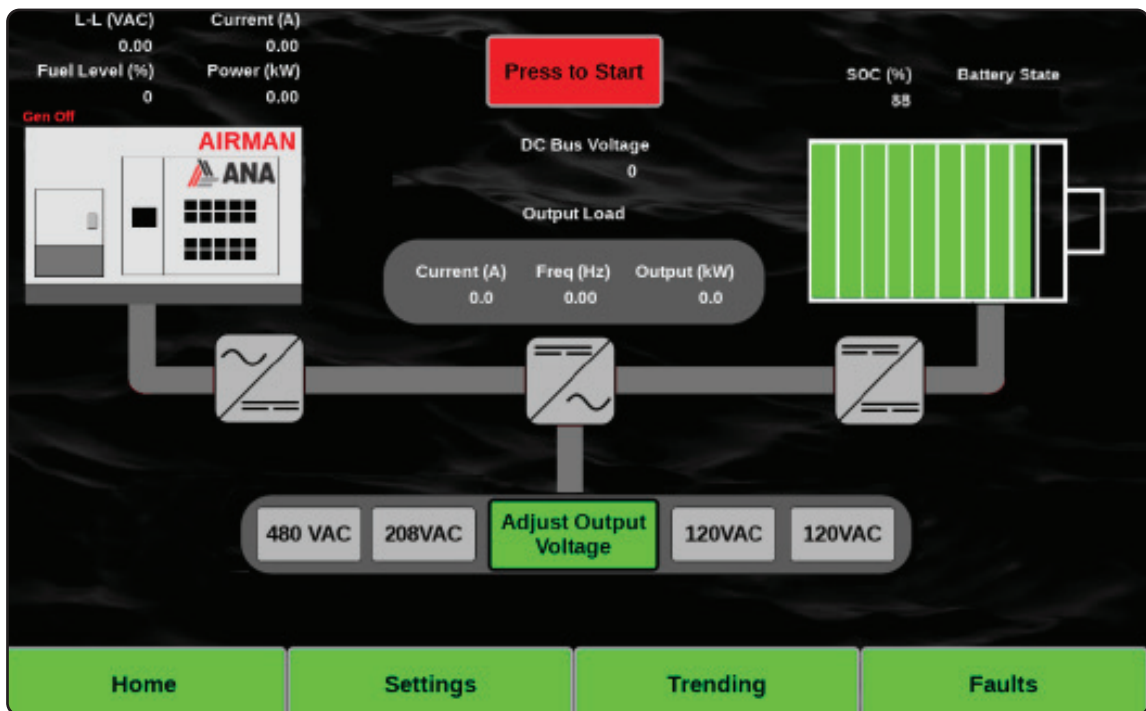

The top left of the screen above the generator shows, line voltage (VAC), current (A), fuel level (%) and power (KW) output of the generator. When the start button is pressed the generator status will display the following:

- Gen Off - before the start button is pressed.
- Gen Run Command - run command initiated to the generator.
- Gen Ready - generator is ready and going through startup.
- Gen Running - generator is online and providing power.

The top right above the battery shows general battery information such as state of charge (SOC) percentage and battery state. When the unit is operating the battery state will either say “charging” or “discharging.”

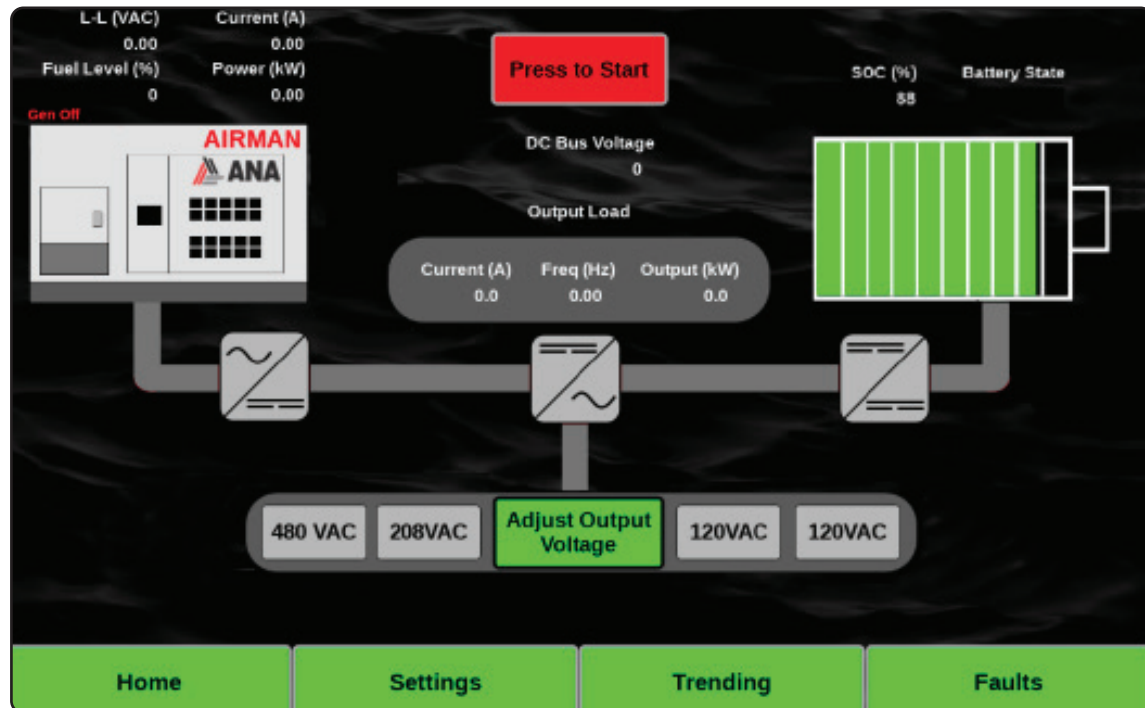

Notice the flow of power between all the major devices:

- Generator to Generator Inverter (AC)
- Generator Inverter to Grid Converter (DC Bus)
- Grid Converter to Load (AC)
- Grid Converter to DC/DC Inverter (DC Bus)
- DC/DC Inverter to Battery Bank (DC)

The flow of power will be either gray (off), green with animated arrows showing direction of power flow (on), or red (faulted). When a major device has faulted the bus associated with that device will be red and a red fault symbol appears. This fault symbol is clickable and will navigate to the fault screen in addition to the fault button on the navigation bar to identify and troubleshoot the issue.

Generator Supplying Power and Charging the Batteries

The screen below shows power going through the generator inverter. The generator inverter is sending power to the output through the grid inverter AND sending power to the batteries for charge. The DC/DC inverter is charging the batteries.

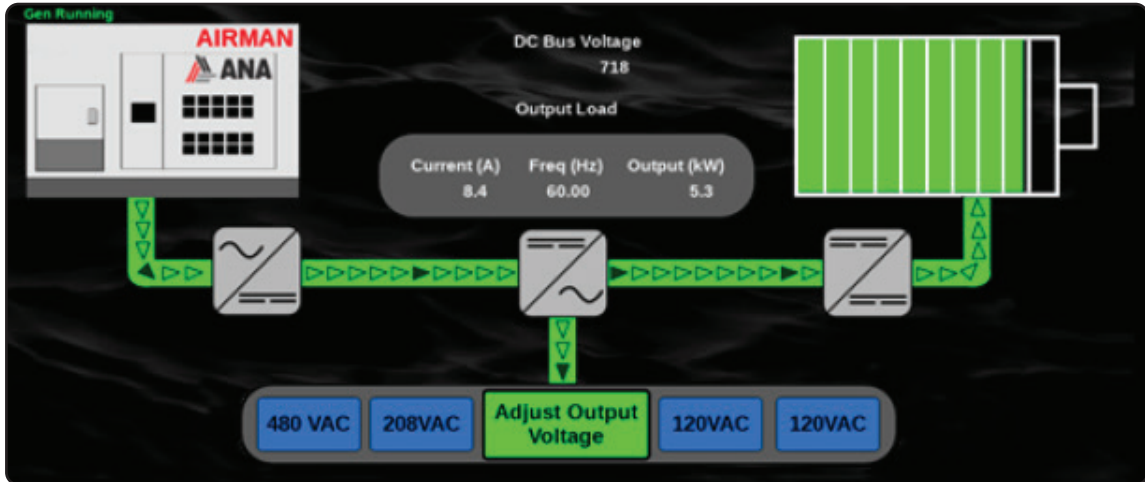

Generator Supplying Power with Generator Off

The screen below shows the generator off. The batteries are supplying power through the DC/DC inverter to the grid converter and to the output.

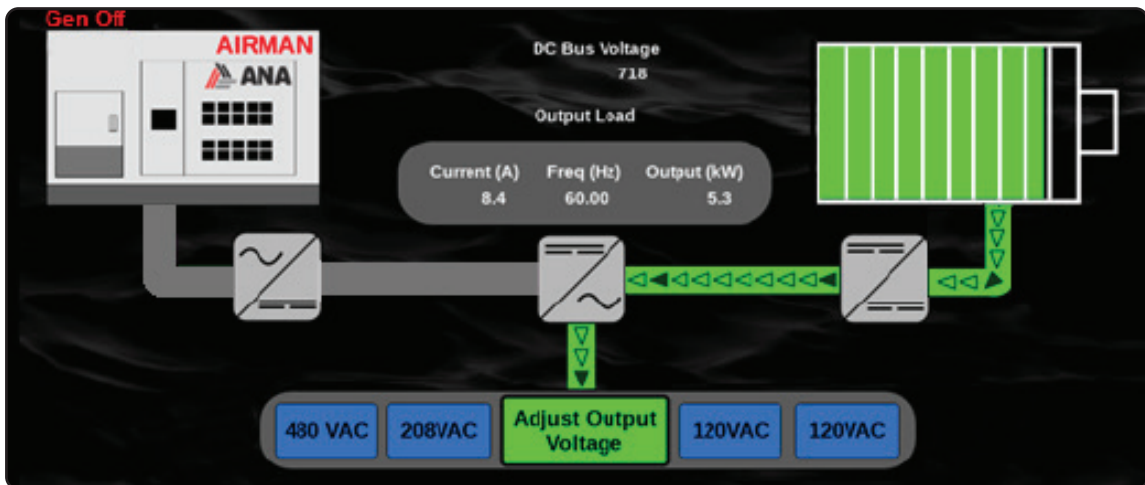

Battery Storage System Supplying Power and Generator Supplying Power to Load (temporary power source)

The screen below shows both the generator and the battery bank supplying power to the load. This is in a rare scenario that the load requirement is greater than the ability for either the generator or the battery but not too great for both of them to supply. This power delivery scenario is only possible temporarily, when the batteries reach the minimum voltage, they will not be allowed to discharge anymore.

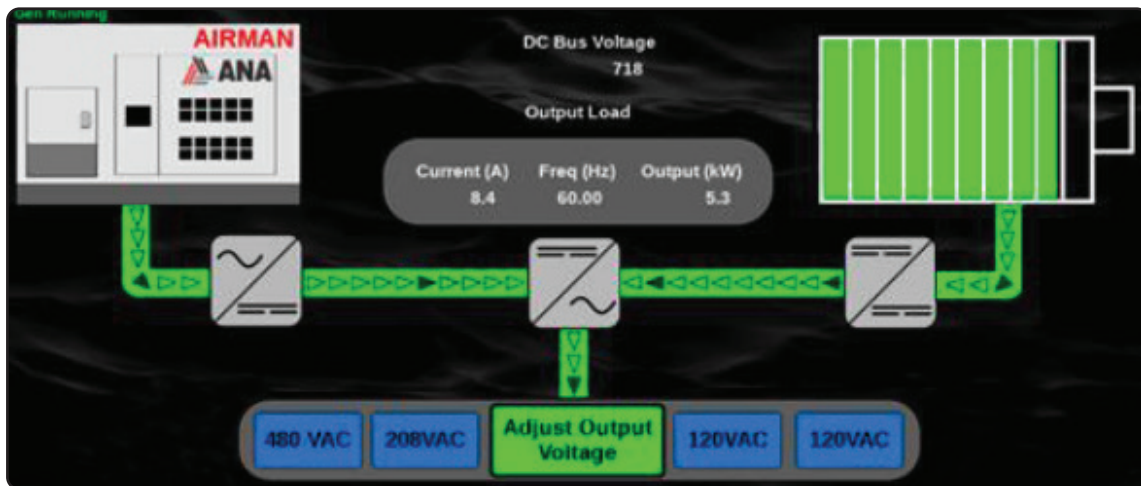

► Faults

When a failure occurs during operation of the EBOSS™, the HMI screen will display a red triangular fault symbol.



When any device fails on the unit, the unit will display a fault symbol which is selectable and will navigate to the faults screen. The user can also view existing faults by using the faults button on the navigation bar.

Faults can be viewed and reset via the HMI screen. Possible fault causes should be investigated by the user in an effort to prevent future faults from occurring. Please contact ANA technical support if repeated faults are experienced with your EBOSS™.

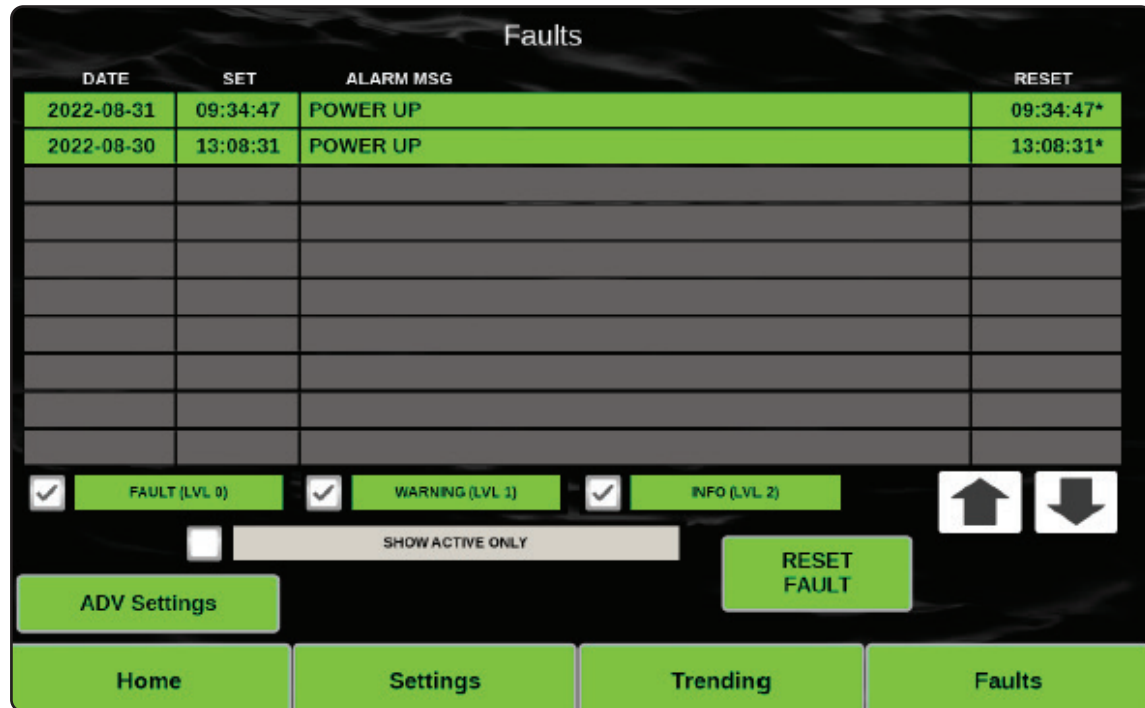

▶ Trending Information

The trend screen displays the following info:

- Gen Off - before the start button is pressed.
- Gen Run Command - run command initiated to the generator.
- Gen Ready - generator is ready and going through startup.
- Gen Running - generator is online and providing power.
- Gen Running - generator is online and providing power.

▶ Remote Monitoring

Telematics - Telematics is a system of software and hardware elements that allows:

- Control of industrial processes locally or at remote locations.
- Monitor, gather, and process real-time data.
- Directly interact with devices such as sensors, valves, pumps, motors, and more through human-machine interface (HMI) software.

From a single unit to an entire fleet, ANA's telematics enables remote access, diagnostics, and monitoring of the EBOSS™. This enables our service technicians to provide an enhanced level of service to your EBOSS™ units in the field.

Generator Status

Telematics is also able to review generator status. This is helpful in reviewing performance value history to determine the overall health and performance of the generator.

▶ Maintenance



This equipment should be serviced by qualified electrical maintenance personnel. Failure to observe this precaution could result in death or severe injury.

The EBOSS™ is generally mated to a standard Airman generator. All standard maintenance on the generator should be followed based off of the recommended service intervals as specified in the generator's user manual.



Completely turn off the EBOSS™ and generator and remove the service disconnects before performing any maintenance. Ensure the service disconnects are twisted off completely and placed away from the mating connector to avoid making any contact.

Internal components of the EBOSS™ should be dusted every 6 months (every 2-3 months in severe conditions). Contactors and breakers maintain the proper flow of electricity, and fans mounted to the inverters and transformers are used to maintain proper operating temperatures of these components.

Compressed air should be used to remove dust and debris from the EBOSS™. Do not make contact between the air nozzle and the sensitive electronics of the EBOSS™, as damage can result.



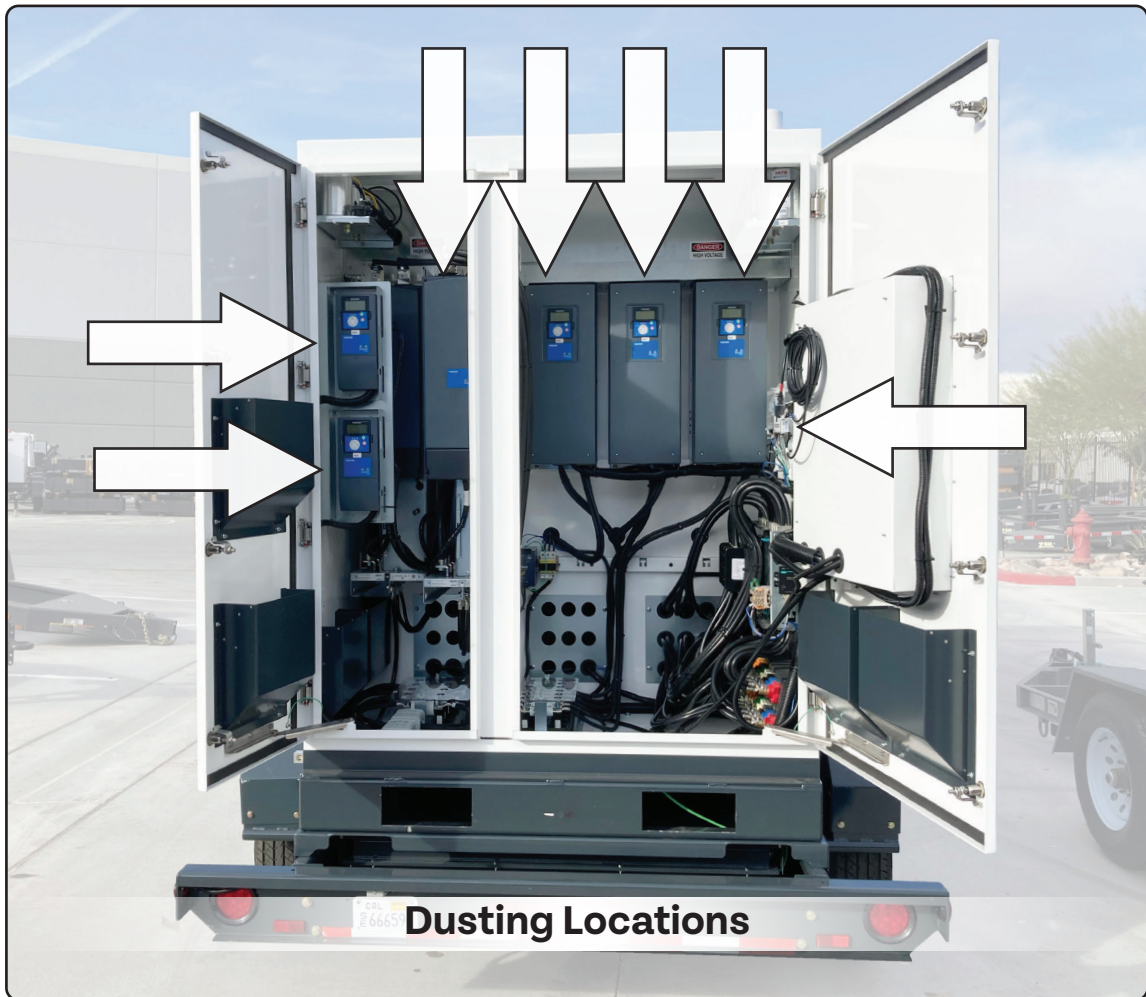

Compressed air should be used to remove dust and debris from the EBOSS™. Do not make contact between the air nozzle and the sensitive electronics of the EBOSS™, as damage can result.

► Storage

The internal battery storage system should be stored with 50% to full-charge while the unit is not in use for long periods. For storage over 1 month, the battery disconnects (orange caps, located on the street side of the battery packs at the base of the unit) may be removed to prevent any measurable battery drain. Disconnect the orange battery disconnects by twisting them counterclockwise and lifting off completely.



This equipment should be serviced by qualified electrical maintenance personnel. Failure to observe this precaution could result in death or severe injury.

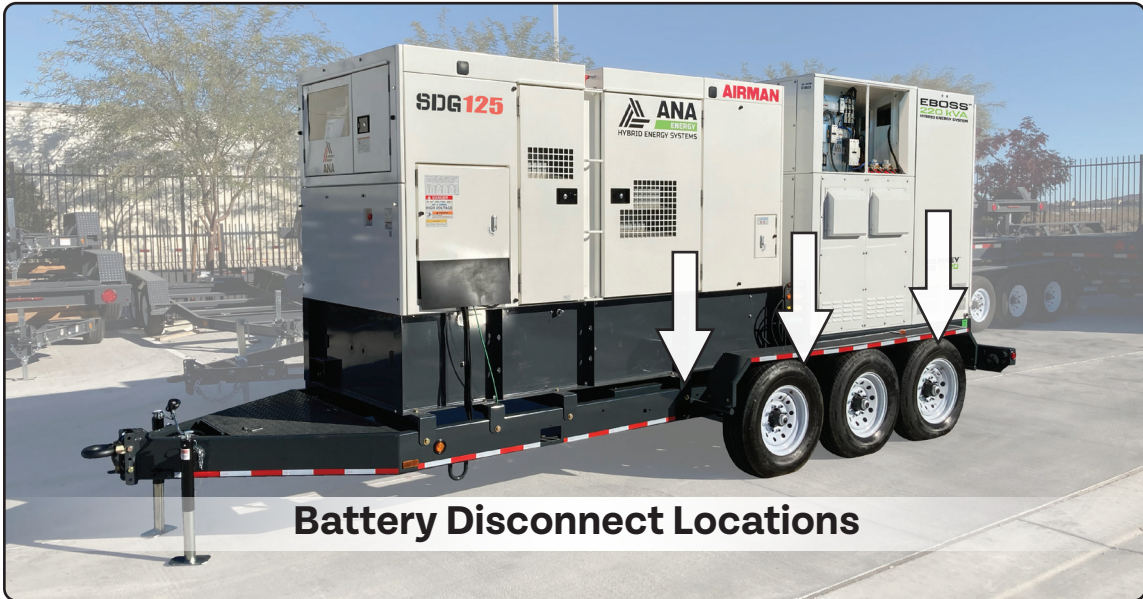

Battery Disconnect Locations

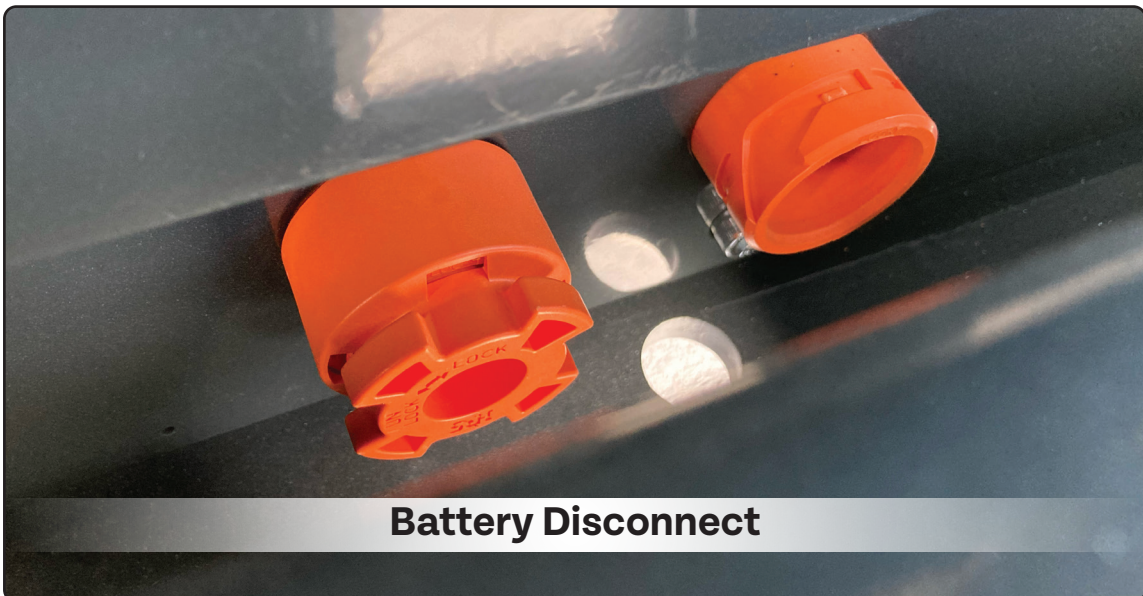

Battery Disconnect

The EBOSS™ is designed to be used outdoors. However, it is recommended that the unit is stored undercover when possible to prevent unnecessary weathering.

► Faults / Alarms

Please refer to your generator's manual for more information and description of the following faults.

| Generator Faults | |
|---------------------------------------|---|
| Generator Emergency Stop | Generator Over Speed |
| Generator Under Speed | Generator High Voltage |
| Generator Low Voltage | Generator Fail to Start |
| Generator Charge Alternator Failure | Generator Oil Pressure Sender Fault |
| Generator Mains Fail to Close | Generator Calibration Lost |
| Generator High Current | Generator Can Ecu Data Fail |
| Generator CAN ECU Shutdown | Generator Expansion Unit Watchdog Alarm |
| Generator Low Fuel Level Switch | Generator Phase Rotation Alarm |
| Generator Earth Fault Trip Alarm | Generator Loading Voltage Alarm |
| Generator Loading Frequency Alarm | Generator Protections Blocked |
| Generator Protections Disabled | Generator Mains Short Circuit |
| Generator Mains Earth Fault | Generator ECU Shutdown |
| Generator ECU Information | Generator ECU Water In Fuel |
| Generator ECU After Treatment | Generator LCD Heater Low Voltage |
| Generator Negative VAR | Generator MSC Old Version |
| Generator SCR Inducement | Generator Fuel Sender Open Circuit |
| Generator MSC Priority Error | Generator Remote Display Link Lost |
| Generator Coolant Sensor Open Circuit | Generator AVR DM1 Red Stop Lamp |
| Generator Fuel Level High | Generator AVR DM1 Red Stop Lamp |
| Generator AVR Data Fail | Generator High Coolant Temperature |
| Generator Low Oil Pressure | Generator Under Frequency |

| Generator Faults (Cont.) | |
|---|--|
| Generator Battery Low Voltage | Generator Over Frequency |
| Generator Fail to Stop | Generator Battery High Voltage |
| Generator Loss of Magnetic Pick Up | Generator Fail to Close |
| Generator Low Fuel Level | Generator Magnetic Pick Up Open Circuit |
| Generator Low Oil Level Switch | Generator CAN ECU Warning |
| Generator KW Overload Alarm | Generator High Temperature Switch |
| Generator Auto Voltage Sense Fail | Generator Negative Phase Sequence Current Alarm |
| Generator Fuel Usage Running | Generator Maintenance Alarm |
| Generator Short Circuit | Generator Fuel Usage Stopped |
| Generator ECU Protect | Generator Mains High Current |
| Generator ECU Warning | Generator ECU Malfunction |
| Generator Reverse Power | Generator ECU Electrical Trip |
| Generator LCD Heater High Voltage | Generator Positive VAR |
| Generator MSC ID Alarm | Generator DEF Level Low |
| Generator Over Speed Runaway | Generator MSC Failure |
| Generator Fuel Tank Bund Level | Generator Over Frequency Runaway |
| Generator Mains Breaker Failed to Open | Generator Charge Air Temperature |
| Generator Escape Mode | Generator Fail to Synchronize |
| Generator Low Coolant Temperature | Generator Coolant High Temp Electrical Trip Unit Overload Warning |

| AFE Faults | |
|---------------------------|-------------------------|
| AFE F1 Over Current Fault | AFE F5 Charge Switch |
| AFE F2 Over Voltage Fault | AFE F7 Saturation Fault |
| AFE F3 Earth Fault | AFE F8 System Fault |

| AFE Faults (cont) | |
|---|---|
| AFE F9 Undervoltage Fault | AFE F56 PT100 Temperature Fault |
| AFE F10 Line Synchronization Fault | AFE F59 SB Heart Beat (SystemBus Com) |
| AFE F11 Line Phase Supervision | AFE F60 Cooling |
| AFE F13 Drive Under Temperature Fault | AFE F62 Run Disable |
| AFE F14 Drive Over Temperature Fault | AFE F63 Quick Stop |
| AFE F22 EEPROM Checksum Fault | AFE F65 PT100 Board 2 |
| AFE F24 Counter Fault | AFE F72 Enter License Code |
| AFE F25 Microprocessor Watchdog Fault | AFE F74 Follower Fault |
| AFE F26 Start-Up Prevention | AFE F76 Synchronization Fault |
| AFE F29 Thermistor Fault | AFE F80 Charging Fault |
| AFE F31 IGBT Temperature | AFE F81 Closed Loop |
| AFE F32 Fan Cooling | AFE F82 External Fault 2 |
| AFE F37 Device Change | AFE F97 Signal Trip |
| AFE F38 Device Added | AFE W29 Thermistor, F56 Measured Temp1, F65 Measured Temp2, F71 LCL Over Temp |
| AFE F39 Device Removed | AFE W11 Supply Phase |
| AFE F40 Device Unknown | AFE W14 Unit Over Temperature |
| AFE F41 IGBT Temperature | AFE F32 Fan Fault, F70 LCL Fan Fault, F60 Cooling Fault |
| AFE F44 Device Changed (Default Param.) | AFE F97 Signal Trip |
| AFE F45 Device Added (Default Param.) | AFE F55 Input Switch |
| AFE F50 4mA Supervision | AFE F64 MCB State Fault |
| AFE F51 External Fault | AFE F66 Klixon |
| AFE F52 Keypad Communication | AFE F67 Fieldbus Communication Slot E |
| AFE F53 Fieldbus Communication | AFE F70 LCL Fan Fault |
| AFE F54 Slot Fault | AFE F71 LCL Temperature |

| AFE Faults (cont) | |
|---------------------------------|-------------------------|
| AFE F83 Generator Inverter Stop | AFE F89 Leakage Fault |
| AFE F84 Insulation | AFE F92 Supply Voltage |
| AFE F85 Earth Switch Fault | AFE F94 E-Stop |
| AFE F86 Arc Relay | AFE F95 Line THD |
| AFE F88 High Amb Temperature | AFE F96 Line HF Voltage |

| DC-DC Faults | |
|--|--|
| DC-DC F1 Over Current Fault | DC-DC F32 Fan Cooling |
| DC-DC F2 Over Voltage Fault | DC-DC F37 Device Change |
| DC-DC F3 Earth Fault | DC-DC F38 Device Added |
| DC-DC F5 Charge Switch | DC-DC F39 Device Removed |
| DC-DC F7 Saturation Fault | DC-DC F40 Device Unknown |
| DC-DC F8 System Fault | DC-DC F41 IGBT Temperature |
| DC-DC F9 Undervoltage Fault | DC-DC F44 Device Changed (Default Param.) |
| DC-DC F10 Line Synchronization Fault | DC-DC F45 Device Added (Default Param.) |
| DC-DC F11 Line Phase Supervision | DC-DC F50 4mA Supervision |
| DC-DC F13 Drive Under Temperature Fault | DC-DC F51 External Fault |
| DC-DC F14 Drive Over Temperature Fault | DC-DC F52 Keypad Communication |
| DC-DC F22 EEPROM Checksum Fault | DC-DC F53 Fieldbus Communication |
| DC-DC F24 Counter Fault | DC-DC F54 Slot Fault |
| DC-DC F25 Microprocessor Watchdog Fault | DC-DC F56 PT100 Temperature Fault |
| DC-DC F26 Start-Up Prevention | DC-DC F59 SB Heart Beat (SystemBus Com) |
| DC-DC F29 Thermistor Fault | DC-DC F60 Cooling |
| DC-DC F31 IGBT Temperature | DC-DC F62 Run Disable |

| DC-DC Faults (cont) | |
|---------------------------------|----------------------------|
| DC-DC F63 Quick Stop | DC-DC F82 External Fault 2 |
| DC-DC F65 PT100 Board 2 | DC-DC F97 Signal Trip |
| DC-DC F72 Enter License Code | DC1 W29 Thermistor |
| DC-DC F74 Follower Fault | DC1 F53 FB Warning |
| DC-DC F76 Synchronization Fault | DC1 F14 Over Temperature |
| DC-DC F80 Charging Fault | DC1 W63 or F62 Quick Stop |
| DC-DC F81 Closed Loop | DC1 W62 or F62 Run Disable |

| Grid Inverter Faults | |
|---|---|
| Grid Inverter F1 Over Current Fault | Grid Inverter F29 Thermistor Fault |
| Grid Inverter F2 Over Voltage Fault | Grid Inverter F31 IGBT Temperature |
| Grid Inverter F3 Earth Fault | Grid Inverter F32 Fan Cooling |
| Grid Inverter F5 Charge Switch | Grid Inverter F37 Device Change |
| Grid Inverter F7 Saturation Fault | Grid Inverter F38 Device Added |
| Grid Inverter F8 System Fault | Grid Inverter F39 Device Removed |
| Grid Inverter F9 Undervoltage Fault | Grid Inverter F40 Device Unknown |
| Grid Inverter F10 Line Synchronization Fault | Grid Inverter F41 IGBT Temperature |
| Grid Inverter F11 Line Phase Supervision | Grid Inverter F44 Device Changed (Default Param.) |
| Grid Inverter F13 Drive Under Temperature Fault | Grid Inverter F45 Device Added (Default Param.) |
| Grid Inverter F14 Drive Over Temperature Fault | Grid Inverter F50 4mA Supervision |
| Grid Inverter F22 EEPROM Checksum Fault | Grid Inverter F51 External Fault |
| Grid Inverter F24 Counter Fault | Grid Inverter F52 Keypad Communication |
| Grid Inverter F25 Microprocessor Watchdog Fault | Grid Inverter F53 Fieldbus Communication |
| Grid Inverter F26 Start-Up Prevention | Grid Inverter F54 Slot Fault |

| Grid Inverter Faults (cont) | |
|--|---|
| Grid Inverter F56 PT100 Temperature Fault | Grid Inverter F1 Over Current Fault |
| Grid Inverter F59 SB Heart Beat (SystemBus Com) | Grid Inverter F3 Earth Fault |
| Grid Inverter F60 Cooling | Grid Inverter F5 Charge Switch |
| Grid Inverter F62 Run Disable | Grid Inverter F7 Saturation Fault |
| Grid Inverter F63 Quick Stop | Grid Inverter F8 System Fault |
| Grid Inverter F65 PT100 Board 2 | Grid Inverter F9 Undervoltage Fault |
| Grid Inverter F72 Enter License Code | Grid Inverter F10 Line Synchronization Fault |
| Grid Inverter F74 Follower Fault | Grid Inverter F11 Line Phase Supervision |
| Grid Inverter F76 Synchronization Fault | Grid Inverter F13 Drive Under Temperature Fault |
| Grid Inverter F80 Charging Fault | Grid Inverter F14 Drive Over Temperature Fault |
| Grid Inverter F81 E-STOP | Grid Inverter F22 EEPROM Checksum Fault |
| Grid Inverter F93 D7 Frequency | Grid Inverter F24 Counter Fault |
| Grid Inverter F96 Line HF Voltage | Grid Inverter F25 Microprocessor Watchdog Fault |
| Grid Inverter F6 Emergency Stop | Grid Inverter F26 Start-Up Prevention |
| Grid Inverter F12 Brake Chopper Supervision | Grid Inverter F29 Thermistor Fault |
| Grid Inverter F42 Brake Resistor Overtemperature | Grid Inverter F31 IGBT Temperature |
| Grid Inverter F57 Identification (Not Implemented) | Grid Inverter F32 Fan Cooling |
| Grid Inverter F68 D7 Voltage or Frequency Fault | Grid Inverter F37 Device Change |
| Grid Inverter F69 OPT-D7 Missing | Grid Inverter F38 Device Added |
| Grid Inverter F73 Supply Frequency | Grid Inverter F39 Device Removed |
| Grid Inverter F77 DC Ground Fault | Grid Inverter F40 Device Unknown |
| GC1 F67 Fieldbus Communication Slot E | Grid Inverter F41 IGBT Temperature |

| Grid Inverter Faults (cont) | |
|---|---|
| Grid Inverter F44 Device Changed (Default Param.) | Grid Inverter F65 PT100 Board 2 |
| Grid Inverter F45 Device Added (Default Param.) | Grid Inverter F72 Enter License Code |
| Grid Inverter F50 4mA Supervision | Grid Inverter F74 Follower Fault |
| Grid Inverter F51 External Fault | Grid Inverter F76 Synchronization Fault |
| Grid Inverter F52 Keypad Communication | Grid Inverter F80 Charging Fault |
| Grid Inverter F53 Fieldbus Communication | Grid Inverter F81 Closed Loop |
| Grid Inverter F54 Slot Fault | Grid Inverter F82 External Fault 2 |
| Grid Inverter F56 PT100 Temperature Fault | Grid Inverter F97 Signal Trip |
| Grid Inverter F59 SB Heart Beat (SystemBus Com) | Grid Inverter W91 Short Circuit |
| Grid Inverter F60 Cooling | Grid Inverter W29 Thermistor |
| Grid Inverter F62 Run Disable | Grid Inverter F53 FB Warning Slot D |
| Grid Inverter F63 Quick Stop | Grid Inverter F67FB Warning Slot E |
| Grid Inverter W14 Unit Temperature | |

| BMU Faults | |
|---|--|
| Current Sensor Abnormality (Sensor Body) | CMU Power Supply Shutdown Abnormality |
| Current Sensor Abnormality (Power Supply) | CMU-CAN Communication Abnormality |
| Current Sensor Abnormality (Signal Line) | Main Contactor (P) Drive Circuit (Short Circuit) |
| CMU-UART Communication Abnormality | Main Contactor (P) Drive Circuit (Ground Fault) |
| CMU Abnormality | GND Control Relay Welding |
| CMU Power Supply Abnormality | GND Control Relay Drive Circuit (Short Circuit) |

| BMU Faults (cont) | |
|--|--|
| GND Control Relay Drive Circuit (Ground Fault) | Main Contactor (N) Welding |
| SDC failure / Fusing / Cable Error Between Modules (open) / Contactor Open Failure | Main Contactor (N) Drive Circuit (Short Circuit) |
| Parallel Connection Configuration Abnormality | Main Contactor (N) Drive Circuit (Ground Fault) |
| AD Reference Voltage Abnormality | Main Contactor (P) Welding |
| Pre-Charge Contactor Drive Circuit (Short Circuit) | Current Leak Sensor Pre-Check Circuit Abnormality |
| Pre-Charge Contactor Drive Circuit (Ground Fault) | Cable Error Between Modules (Ground Fault/Current Leak Detection) |
| Current Leak Sensor Power Supply Abnormality | Backup Abnormality |

Technical Support

Any servicing, diagnostics, or repairs should only be performed by trained personnel equipped with the proper tools and safety equipment. Please contact our technical support team for further information or to assist with repairs.

ANA Technical Support

Phone: 1-562-450-3570 Opt 3

Email: support@anacorp.com

anacorp.com

▶ Troubleshooting

The following chart lists potential issues, their causes, and solutions. If you are unable to resolve your issue, please contact our service department and they can assist you.

Warning - Hazardous High Voltage



This equipment should be installed, adjusted, and serviced by qualified electrical maintenance personnel familiar with the construction and operation of this type of equipment and the hazards involved. Failure to observe this precaution could result in death or severe injury.

| Troubleshooting Chart | | |
|--|--|---|
| Issue | Possible Cause(s) | Suggestion |
| Unit is on but there is no output power. | The output circuit breaker may not be switched on. | Check that the circuit breaker is pushed up to the on position. |
| | “Load Control” is off. | Review the configured “Load Control” or change to ON. |
| | Emergency Stop may be activated. | De-activate the emergency stop. |
| | Limit switch may be open. | Close the bottom front door. |
| | Battery SoC is below 5% and no source of power is connected to the EBOSS™. | Check fuel level on the generator or check if “Auto Start” is on. |
| The system power has been switched on but there is no display on HMI screen. | The HMI Fuse may have blown. | Replace the HMI fuse. |
| | The 24V DC Regulator Fuse may have blown. | Replace the 24V DC Regulator Fuse. |

| Troubleshooting Chart | | |
|---|---|--|
| Issue | Possible Cause(s) | Suggestion |
| There is power being sent to the EBOSS™, but it is not charging or passing through power. | The AC input Fuses may be disconnected or blown. | Check the AC input fuses, connect or replace if necessary. |
| | The HMI “Load Control” is OFF. | Review the configured “Load Control” or change to ON. |
| External power source is active (ex, diesel generator is running) but power is only passing through on first phase (L1) | Phase rotation of diesel generator or its connecting cable is incorrect. | Check the phase rotation of the supplying generator and its cable. |
| | Damaged cable between diesel generator and EBOSS™. | Test or replace cables and connectors. |
| Output voltage is lower than desired voltage over distance. | If the distance between the unit and the consumers is more than 50 meters, the voltage can drop too low. | Contact ANA Technical services to arrange adjustment of system settings. |
| SoC reading 0% and AC output are disconnected. | This indicates that the storage voltage has reached its lower limit and has turned off its output to protect the batteries. | Charge EBOSS™ from the generator and follow “Start Up” procedure. Please contact ANA Technical Support. |
| Output circuit breaker continually trips. | The consumers being connected draw too much power for the rated output of the unit. | Refer to the maximum output rating on the unit’s rating plate and reduce the total power draw accordingly. |
| Input Fuses continually blow | AC Input current set too high | Lower input current to match input source rating. Replace blown fuses if necessary. |
| | Generator remote start signal cable is loose or has been damaged. | Reattach or replace the cable. |

| Troubleshooting | | |
|--------------------------------------|--|---|
| Issue | Possible Cause(s) | Suggestion |
| Remote Generator Start not working. | Remote start switching mode incorrect (normally open / normally closed). | For details on changing the switching mode, please contact ANA Technical Support. |
| | Diesel generator is in manual mode. | Switch diesel generator to automatic mode. |
| | Generator remote start not configured properly. | Contact Technical Support for the generator. |
| | EBOSS™ may be in manual ON generator mode. | Check the state of the generator remote control. |
| Diesel generator constantly running. | There may be phase imbalance - too much power is being drawn on one phase. | Power should be distributed evenly across the three phases as much as possible. |
| | The load may be too high. | Reduce the load. |

▶ **Notice - Please Read**

The product discussed in this literature is subject to terms and conditions outlined in the selling policies of Alliance North America (ANA, Inc.). The sole source governing the rights and remedies of any purchaser of this equipment is the relevant selling policy of ANA Inc.

NO WARRANTIES, EXPRESS OR IMPLIED, INCLUDING WARRANTIES OF FITNESS FOR A PARTICULAR PURPOSE OR MERCHANTABILITY, OR WARRANTIES ARISING FROM COURSE OF DEALING OR USAGE OF TRADE, ARE MADE REGARDING THE INFORMATION, RECOMMENDATIONS AND DESCRIPTIONS CONTAINED HEREIN.

In no event will ANA be responsible to the purchaser or user in contract, in tort (including negligence), strict liability or otherwise for any special, indirect, incidental or consequential damage or loss whatsoever, including but not limited to damage or loss of use of equipment, plant or power system, cost of capital, loss of power, additional expenses in the use of existing power facilities, or claims against the purchaser or user by its customers resulting from the use of the information, recommendations and descriptions contained herein.

The information contained in this manual is subject to change without notice.

ANA, Inc.

1740 Raiders Way
Henderson, NV 89052
anacorp.com

Sales and Support

Phone: 1-562-450-3570 Opt 3
Email: support@anacorp.com
Email: sales@anacorp.com

Page Intentionally Left Blank



ANA
ENERGY
HYBRID ENERGY SYSTEM

EBOSS™
220 kVA
- HYBRID SYSTEM -

Operation Manual