



ANA

We make your world easier.



EBOSS[®]
25-25
 -HYBRID SYSTEM-
 25 / 30 kVA
 PRIME / PEAK POWER

U.S. Patent No. 12,283,8222

AIRMAN[®] Generator Tier 4F Final | ISUZU[®] 42LE2T Engine

EBOSS[®] HYBRID ENERGY SYSTEMS BENEFITS

20X

UP TO 20X THE
CYCLE LIFE OF
NMC/LFP BATTERIES



SAFE BATTERY
TECHNOLOGY
NO THERMAL RUNAWAY

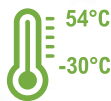

WIDEST
TEMPERATURE
OPERATING RANGE

1Φ AND 3Φ

SIMULTANEOUS
1 AND 3 PHASE
OUTPUT VOLTAGES



REMOTE ACCESS
MONITORING &
TRACKING



INDUSTRIAL
GRADE
INVERTERS

JOURNEY TO ZERO[®]

► How It Works

EBOSS®
25-25

The generator charges the EBOSS® battery, then shuts down while the EBOSS® powers the load until the battery is depleted. This cycles multiple times per day, allowing the generator to run less frequently, reducing fuel consumption, run time, and emissions.

Charging the EBOSS®

The generator charges the EBOSS® battery. Once the battery is fully charged, the generator shuts off.

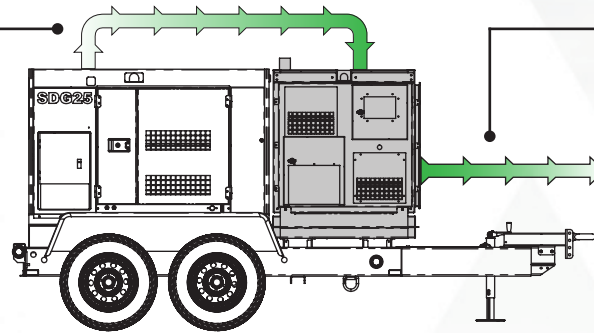

Powering the Load

The stored energy in the battery provides power to the load. Once the battery discharges to 15% capacity, the generator starts up again to charge the battery.

EBOSS® Advantage

// Ease of Use

EBOSS® is easier to use, operate, and integrate as a hybrid system with a standard diesel generator.

// Scalability

EBOSS® is easily scalable to dozens of units without any additional hardware or specialty controls required.

// Battery Chemistry

EBOSS® uses LTO battery chemistry, which is much more efficient and safer than the competition's LFP.

// Battery Life

EBOSS® LTO battery packs can last 40+ years (up to 10x longer than the competition's LFP).

// Energy Uptime

Ultra high cycle life LTO batteries can fully charge in 45 min, the competition charges in 4+ hours.

// Telematics

EBOSS® Telematics provides remote monitoring and reporting 24hrs/day anywhere in the world.

// Product Support

World class product support, with trained and knowledgeable technicians answering your calls 24hrs/day.

// Climate Versatility

EBOSS® performs effortlessly in virtually any climate or environment around the world from -22°F to 130°F (-30°C to 54°C).

► Specifications

EBOSS®
25-25

EBOSS® Specifications			
Generator Input	20kW max		
Battery Capacity	15kWh		
EBOSS® Output	20kW max (24 Amp Load)		
Frequency	60Hz		
Total Battery Life (Energy Throughout)	1,200 MWh		
Battery Cycles / Battery Life (100° F)	80K / 41 Years		
Battery Chemistry	Lithium Titanium Oxide (LTO)		
Operating Temp	-22°F to 130°F (-30°C to 54°C)		
Inverter Cold Start Temp	14°F (-10°C) minimum		
Charge Time (No Load)	~45 min		
Telematics	Monitoring & Reporting		
Parallel Capability	Unlimited		
Dimensions (LxWxH)	Skid 40.62" x 50.29" x 54.83" (1032mm x 1277mm x 1393mm)		
	Hybrid 154.88" x 71.12" x 75.53" (3934mm x 1806mm x 1918mm)		
Weight (Empty / Fueled)	Power Module 2,133lbs (968kg)		
	Hybrid 5,100lbs / 5,500lbs (2,313kg / 2,495kg)		
Maximum Intermittent Power Output (Battery SOC Greater than 5%)			
Three Phase	30kVA / 24kW		
Simultaneous Voltage (Three Phase)	120 / 208 / 277 / 480		
Single Phase	20kVA / 16kW		
Simultaneous Voltage (Single Phase)	120 / 240		
Frequency	60Hz		
Voltage Regulation	Adjustable		
Maximum Continuous Power Output (Battery SOC at 0%)			
Generator	Airman SDG25		
Generator Charge Rate	25kVA / 20kW		
Three Phase Output	23kVA / 19kW		
Single Phase Output	20kVA / 16kW		
Simultaneous Voltage (Three Phase)	120 / 208 / 277 / 480		
Simultaneous Voltage (Single Phase)	120 / 240		
Warranty			
2 Year EBOSS®		7 Year Battery	
Optional Equipment			
Cold Weather Package	Arctic Package	Solar Panels	600V Option

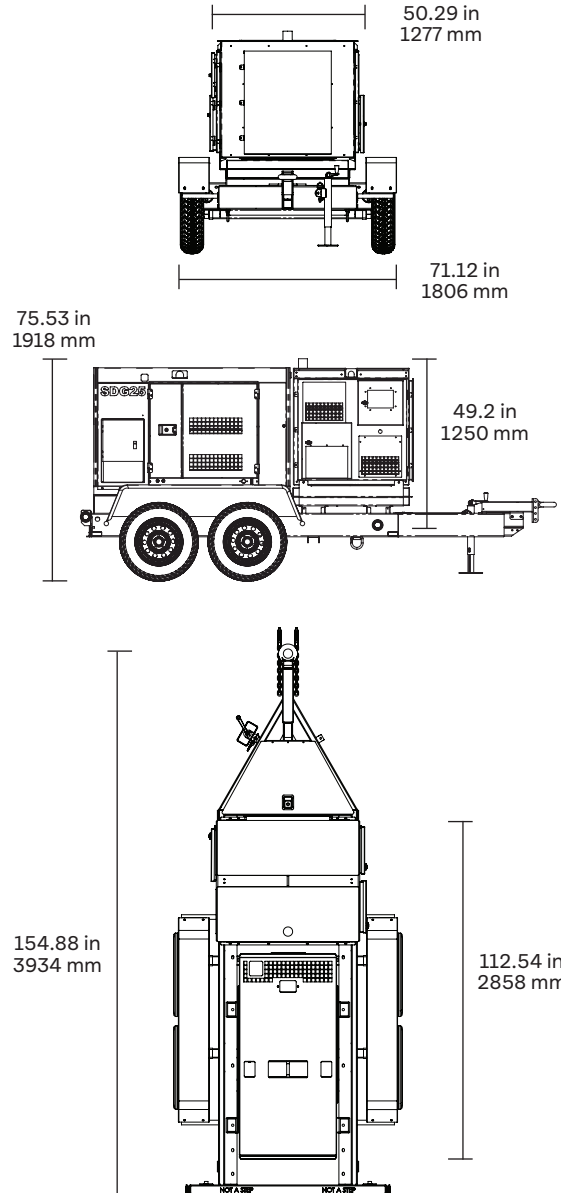

EBOSS® Breaker Type		Rating	QTY
Input	Generator	100A	1
Output	480V 3 Phase (grid inverter output)	100A	1
	480V 3 Phase	30A	1
	208V 3 Phase	65A	1
	240V 1 phase Cam Locks	80A	1
	240V 1 phase twist locks	45A	1
	120V GFCI	20A	1
EBOSS® 600V Specifications			
Max Amperage (continuous)		20 Amps @ 600V	
Max Intermittent Amperage		25 Amps @ 600V	
Motor Starting Amperage		35 Amps @ 600V	

*Specifications shown subject to change without notice. Please contact ANA for current specifications and model information.

Learn More About



ANA

We make your world easier.

ANACORP.COM



EBOSS[®]



SOLD AND SERVICED BY

Cypress, CA // Henderson, NV // Spartanburg, SC
Executive Offices // 1770 Raiders Way, Henderson, NV 89052
1 (562) 450-3570 // sales@anacorp.com // www.anacorp.com

*Specifications shown are subject to change without notice.
Please contact ANA, Inc for current specifications and model information.

EB25-25SV1.26