



# ANA

We make your world easier.



**EBOSS<sup>®</sup>**  
**25kVA**  
**- POWER MODULE -**  
**23 / 30 kVA**  
**PRIME / PEAK POWER**

U.S. Patent No. 12,283,8222

**Ultra-High Cycle Life LTO Batteries | 3-Phase Inverters**

## EBOSS<sup>®</sup> HYBRID ENERGY SYSTEMS BENEFITS

**20X**

UP TO 20X THE  
CYCLE LIFE OF  
NMC/LFP BATTERIES



SAFE BATTERY  
TECHNOLOGY  
NO THERMAL RUNAWAY



WIDEST  
TEMPERATURE  
OPERATING RANGE

**1Φ AND 3Φ**

SIMULTANEOUS  
1 AND 3 PHASE  
OUTPUT VOLTAGES



REMOTE ACCESS  
MONITORING &  
TRACKING



INDUSTRIAL  
GRADE  
INVERTERS

# JOURNEY TO ZERO<sup>®</sup>

# ► How It Works

**EBOSS®**  
**25kVA**

The generator charges the EBOSS® battery, then shuts down while the EBOSS® powers the load until the battery is depleted. This cycles multiple times per day, allowing the generator to run less frequently, reducing fuel consumption, run time, and emissions.

## Charging the EBOSS®

The generator charges the EBOSS® battery. Once the battery is fully charged, the generator shuts off.

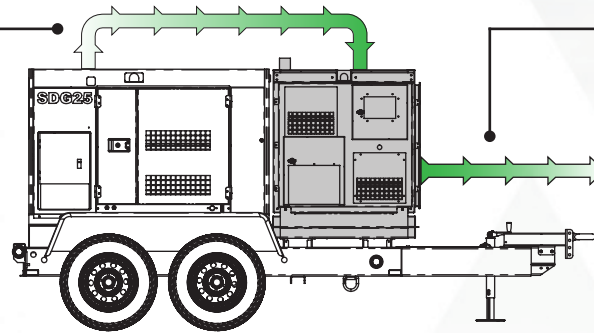

## Powering the Load

The stored energy in the battery provides power to the load. Once the battery discharges to 15% capacity, the generator starts up again to charge the battery.

## EBOSS® Advantage

### // Ease of Use

EBOSS® is easier to use, operate, and integrate as a hybrid system with a standard diesel generator.

### // Scalability

EBOSS® is easily scalable to dozens of units without any additional hardware or specialty controls required.

### // Battery Chemistry

EBOSS® uses LTO battery chemistry, which is much more efficient and safer than the competition's LFP.

### // Battery Life

EBOSS® LTO battery packs can last 40+ years (up to 10x longer than the competition's LFP).

### // Energy Uptime

Ultra high cycle life LTO batteries can fully charge in 45 min, the competition charges in 4+ hours.

### // Telematics

EBOSS® Telematics provides remote monitoring and reporting 24hrs/day anywhere in the world.

### // Product Support

World class product support, with trained and knowledgeable technicians answering your calls 24hrs/day.

### // Climate Versatility

EBOSS® performs effortlessly in virtually any climate or environment around the world from -22°F to 130°F (-30°C to 54°C).

# ► Specifications

**EBOSS®**  
**25kVA**

EBOSS® Specifications			
Generator Input	20kW max		
Battery Capacity	15kWh		
EBOSS® Output	20kW max (24 Amp Load)		
Frequency	60Hz		
Total Battery Life (Energy Throughout)	1,200 MWh		
Battery Cycles / Battery Life (100° F)	80K / 41 Years		
Battery Chemistry	Lithium Titanium Oxide (LTO)		
Operating Temp	-22°F to 130°F (-30°C to 54°C)		
Inverter Cold Start Temp	14°F (-10°C) minimum		
Charge Time (No Load)	~45 min		
Telematics	Monitoring & Reporting		
Parallel Capability	Unlimited		
Dimensions (LxWxH)	Skid 40.62" x 50.29" x 54.83" (1032mm x 1277mm x 1393mm)		
	Hybrid 154.88" x 71.12" x 75.53" (3934mm x 1806mm x 1918mm)		
Weight (Empty / Fueled)	Power Module 2,133lbs (968kg)		
	Hybrid 5,100lbs / 5,500lbs (2,313kg / 2,495kg)		
Maximum Intermittent Power Output (Battery SOC Greater than 5%)			
Three Phase	30kVA / 24kW		
Simultaneous Voltage (Three Phase)	120 / 208 / 277 / 480		
Single Phase	20kVA / 16kW		
Simultaneous Voltage (Single Phase)	120 / 240		
Frequency	60Hz		
Voltage Regulation	Adjustable		
Maximum Continuous Power Output (Battery SOC at 0%)			
Generator (example)	Airman SDG25		
Generator Charge Rate	25kVA / 20kW		
Three Phase Output	23kVA / 19kW		
Single Phase Output	20kVA / 16kW		
Simultaneous Voltage (Three Phase)	120 / 208 / 277 / 480		
Simultaneous Voltage (Single Phase)	120 / 240		
Warranty			
2 Year EBOSS®		7 Year Battery	
Optional Equipment			
Cold Weather Package	Arctic Package	Solar Panels	600V Option

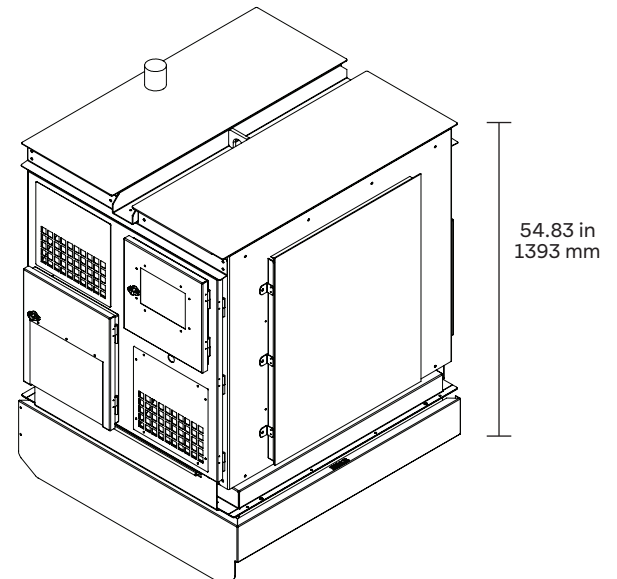
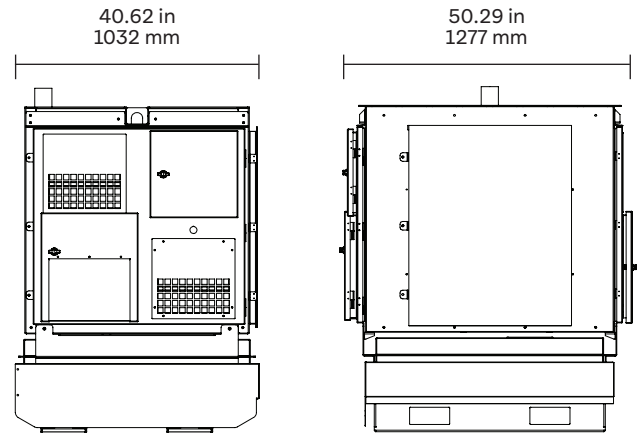

EBOSS® Breaker Type		Rating	QTY
Input	Generator	100A	1
Output	480V 3 Phase (grid inverter output)	100A	1
	480V 3 Phase	30A	1
	208V 3 Phase	65A	1
	240V 1 phase Cam Locks	80A	1
	240V 1 phase twist locks	45A	1
	120V GFCI	20A	1

\*Specifications shown subject to change without notice. Please contact ANA for current specifications and model information.

**Learn More About**



**ANA**

We make your world easier.

**ANACORP.COM**



**EBOSS<sup>®</sup>**



SOLD AND SERVICED BY

**Cypress, CA // Henderson, NV // Spartanburg, SC**  
**Executive Offices // 1770 Raiders Way, Henderson, NV 89052**  
**1 (562) 450-3570 // sales@anacorp.com // www.anacorp.com**

\*Specifications shown are subject to change without notice.  
Please contact ANA, Inc for current specifications and model information.

EB25PMSV1.26