



ANA

ENERGY

HYBRID ENERGY SYSTEM

EBOSS™

70kVA

- HYBRID SYSTEM -



Operation Manual

V1 - 11.26.24 PN: 300000211

Page Intentionally Left Blank

Thank you for purchasing the EBOSS™.

The ANA EBOSS™ is a hybrid energy system that integrates a very efficient diesel generator with our ultra-high cycle life lithium battery storage system optimized to reduce noise, emissions, maintenance, and fuel consumption.

The EBOSS™ Human Machine Interface (HMI) is the central control software and hardware of the system, accessed via a touchscreen control panel enabling high-level monitoring and control over the entire system.

The EBOSS™ Telematics platform allows owners to manage their single unit or complete fleet of EBOSS™ units. It enables monitoring and reporting on each unit and the entire fleet at multiple levels to support the various customer user groups from end users to fleet managers to service engineers. The HMI provides the best means of managing the energy storage system and generator allowing users to get the most out of both systems and respond to customers' needs more effectively.

This manual provides the steps needed to operate, manage, and maintain the EBOSS™ safely and effectively throughout its long operational life. ANA provides a two year base warranty on the generator and all its associated equipment and a seven year product warranty on the battery. ANA offers various levels of extended warranties designed to suit your needs so please contact us about your requirements.

Please note, due to constant product improvement, the specifications, photos, and procedures listed in this manual are subject to change without notice. Please contact ANA directly for the most up to date information on the EBOSS™ product line.

ANA, Inc.
1770 Raiders Way
Henderson, NV 89052
anacorp.com

Sales and Support
Phone: 1-562-450-3570 Opt 3
Email: support@anacorp.com
Email: sales@anacorp.com

Table of Contents

06 | **About ANA**

Information about ANA, Inc.

07 | **About EBOSS™**

Features, benefits, and overview of the EBOSS™.

08 | **Specifications**

EBOSS™ specifications, dimensions, and decals.

22 | **Safety**

Safety explanation and warning symbols.

25 | **Definitions**

Definitions and acronyms used in this manual.

26 | **Transport and Towing**

How to safely transport and tow the EBOSS™ unit.

37 | **Fueling & Grounding**

Safe fueling and grounding procedures.

38 | **Setup for Operation**

How to setup the EBOSS™ for operation.

39 | **Start Up / Shut Down**

How to start up the unit and safely shut it down.

42 | **Power Sources**

All available power sources provided by the EBOSS™.

43 | **Batteries**

Battery function and operation.

44 | **Operation Sequence**

How to safely operate the EBOSS™.

45 | **Cold Weather**

Operating the EBOSS™ in cold weather.

47 | **Parallel Mode**

Operating the EBOSS™ in parallel mode.

48 | **HMI Display**

Operation of the Human Machine Interface (HMI).

50 | **Battery Information**

Battery information shown in the HMI display.

51 | **Fault Information**

Fault information shown in the HMI display.

52 | **Trending Information**

Trending information shown in the HMI display.

54 | **Remote Monitoring**

Information about EBOSS™ telematics.

54 | **Maintenance**

Maintenance procedures of the EBOSS™.

56 | **Storage**

Information about proper storage of the EBOSS™.

58 | **Warnings and Alarms**

Index of common warnings and alarms.

64 | **Troubleshooting**

Troubleshooting information for the EBOSS™.

70 | **Warranty Info**

Warranty information about the EBOSS™.

▶ About ANA

Founded in 2017, ANA, Inc is a customer focused, rapidly growing company specializing in the construction, industrial, utilities, telecom, and rental equipment sectors. ANA is the exclusive North American supplier of AIRMAN mobile generators and air compressors.

ANA also designs and manufactures the EBOSS™, a hybrid energy system revolutionizing the mobile power generation industry.

▶ ANA Locations



Cypress, CA

- Engineering
- Planning
- Warehouse



Henderson, NV

- Corporate HQ
- Engineering
- Production
- Training



Spartanburg, SC

- Production
- Distribution
- Warehouse

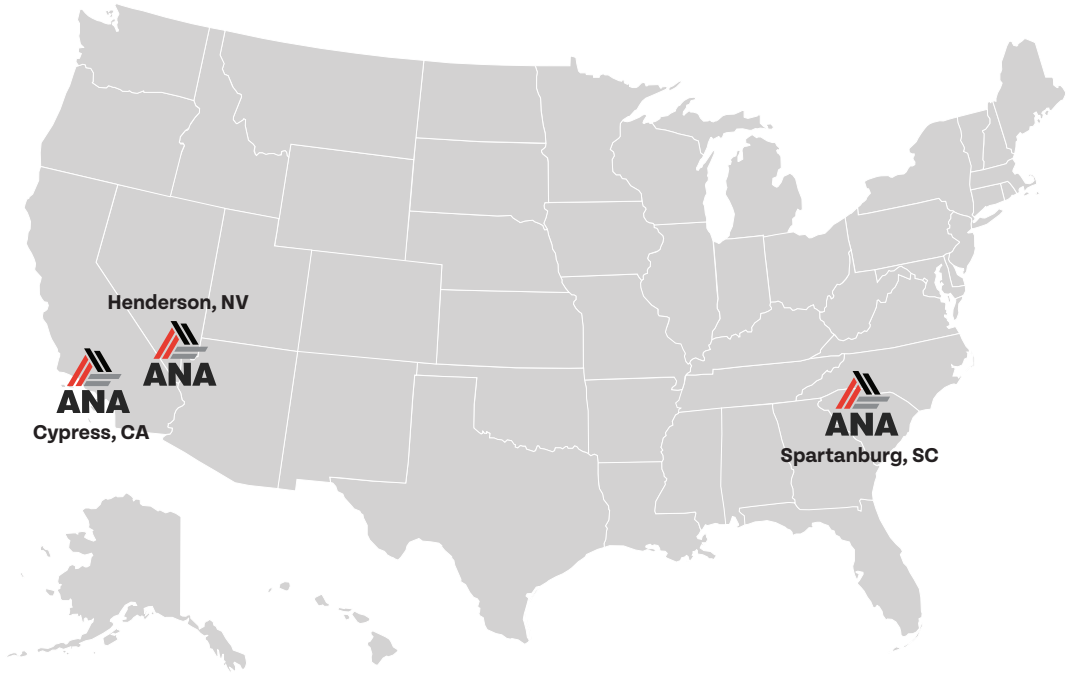

► About EBOSS™

The EBOSS™ hybrid energy system provides an energy efficient power generation solution that provides clean power, long battery life, reduced emissions, lower maintenance costs, with an improved ROI over just running a generator alone. Using a generator to charge battery packs that provide outgoing electrical power, the EBOSS™ significantly reduces generator runtime and fuel consumption.

► How It Works

The generator starts up and charges the EBOSS™ battery. Once fully charged, the generator shuts off and the EBOSS™ provides several hours of clean, quiet power to the load. When the EBOSS™ battery drops below approximately 15% capacity, the generator starts up again to charge the EBOSS™. In low load applications the EBOSS™ can be fully charged in less than an hour.

Charging the EBOSS™

The generator charges the EBOSS™ battery. Once the battery is fully charged, the generator shuts off.

Powering the Load

The stored energy in the battery provides power to the load. Once the battery discharges to approx 15% capacity, the generator starts up again to charge the battery.

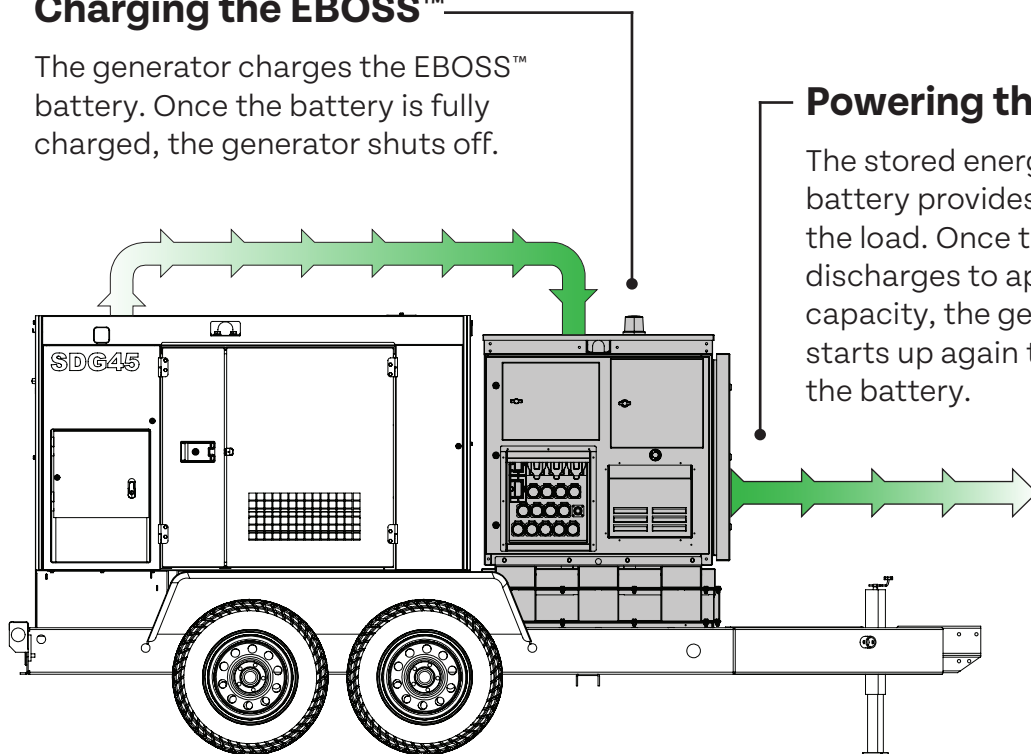

▶ EBOSS™ Specifications

EBOSS™ 70kVA specifications.

Specifications	EBOSS™ 70kVA
Hybrid Energy System	ANA EBOSS™
Prime Output	
Three - Phase	70kVA / 56kW
Single - Phase	47kVA / 37kW
Frequency	60Hz
Voltage (Three - Phase), Simultaneous	208 / 480
Voltage (Single - Phase), Simultaneous	120 / 240
Voltage Regulation	Adjustable
Output Panel	
Single - Phase (120V)	20A
Single - Phase (240V)	50A Twist Lock
Three - Phase (480V)	480V Cam-Loks
Three - Phase (208V)	208V Cam-Loks
Single - Phase (240V)	240V Cam-Loks
Controls	
Control Panel	10" Full Color Touch Screen
Telematics	Generator & EBOSS™
ESG Reporting	Yes
Technology	
Battery Chemistry	Lithium Titanate Oxide (LTO)
Inverter	Industrial Grade 3-Phase, 25kW
Battery System Voltage	360V - 648V
DC BUS Voltage	600+ DC

▶ EBOSS™ Specifications (Cont)

EBOSS™ 70kVA specifications.

Battery Life*	EBOSS™ 70kVA
Battery Type	Lithium Titanate Oxide (LTO)
Battery Size	25kWh
Est. Life Cycle @ 77°F Laboratory Cond.	90k Cycles at 90% DOD
Est. Life Cycle @ 100°F Enclosure Temps.	80k Cycles at 90% DOD
Battery Life (100°F) @ 3kW Average Load	41 Years
Operating Temperatures	
Inverter Cold Start Temperature (min)	14°F (-10°C)
Running Operating Temperature	-22°F to 130°F (-30°C to 54°C)
Arctic Package Operating Temp (optional)	-50°F to 130°F (-45°C to 54°C)
Battery Charging Temperature	-22°F to 130°F (-30°C to 54°C)
Weights & Dimensions	
Length x Width x Height (EBOSS™ only)	55" x 44" x 62"
Skid Weight (EBOSS™ only)	2,513lbs
Length x Width x Height (w/ trailer and generator)	167" x 71" x 76"
Total Weight (empty / fueled)	5,988lbs / 6,600lbs
Warranty	
EBOSS™ Only	2 Years
EBOSS™ with Trailer & Generator	2 Years, 2000 Hours
Manufacturer Battery Warranty	7 Years
Service & Support	24/7, 365 Days
Training	
EBOSS™ Training	Henderson, NV or On Location

*Battery expected to retain 95% of its life after 7 years under 24/7 operation at 3kW average load.

▶ EBOSS™ Components

EBOSS™ 70kVA hybrid component information.

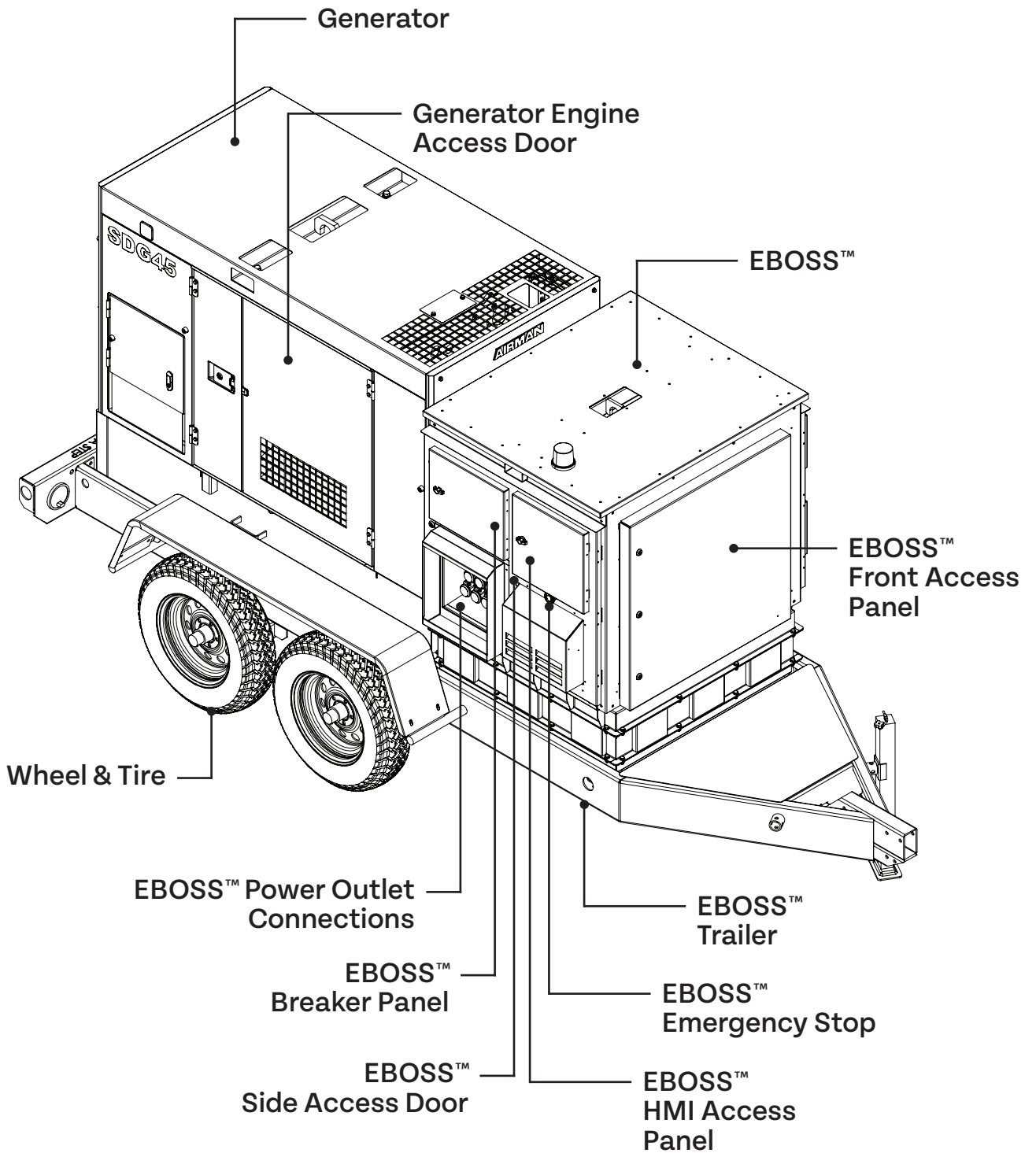

▶ EBOSS™ Components

EBOSS™ 70kVA hybrid component information.

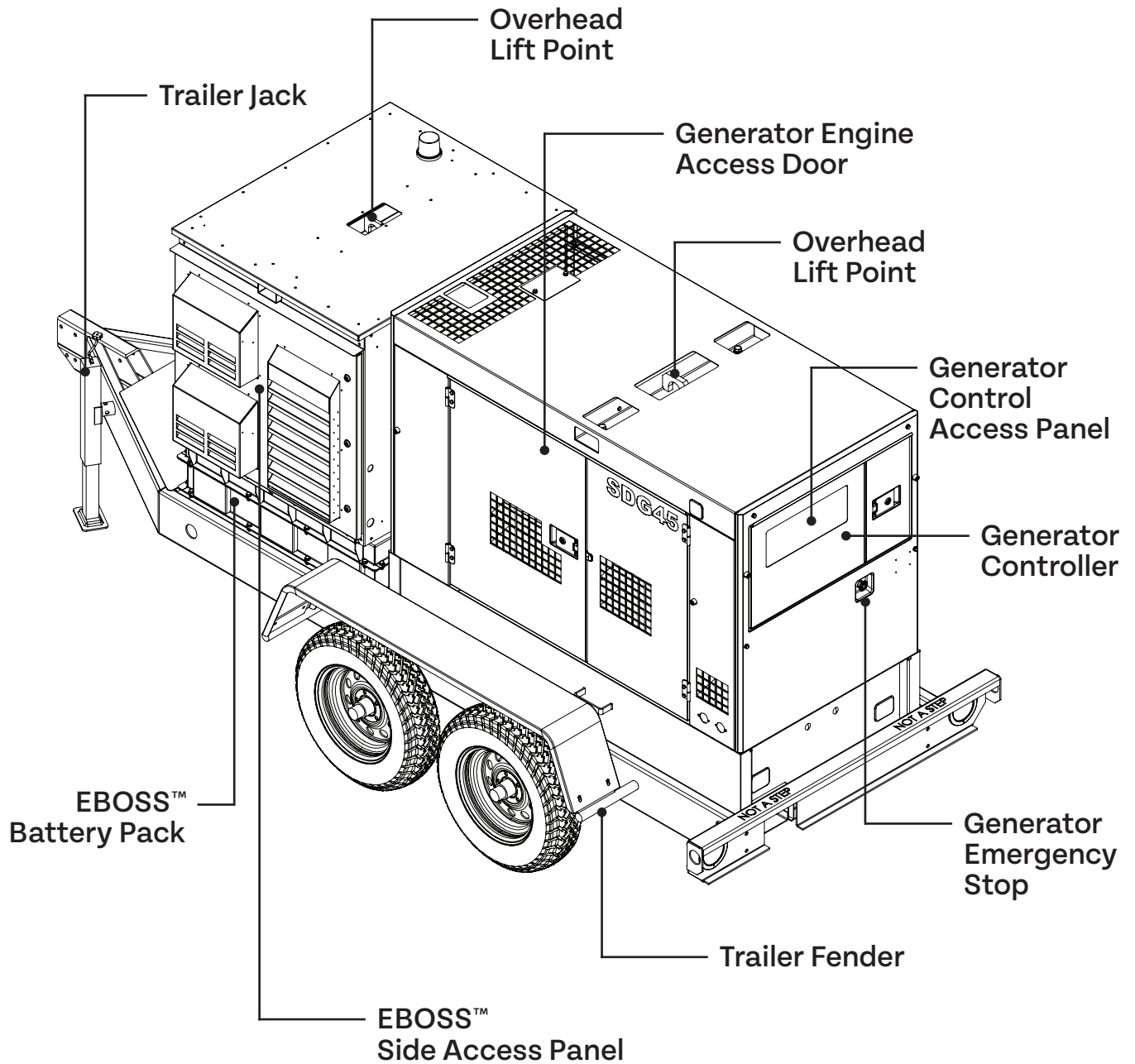

▶ EBOSS™ Dimensions

EBOSS™ 70kVA hybrid specifications.

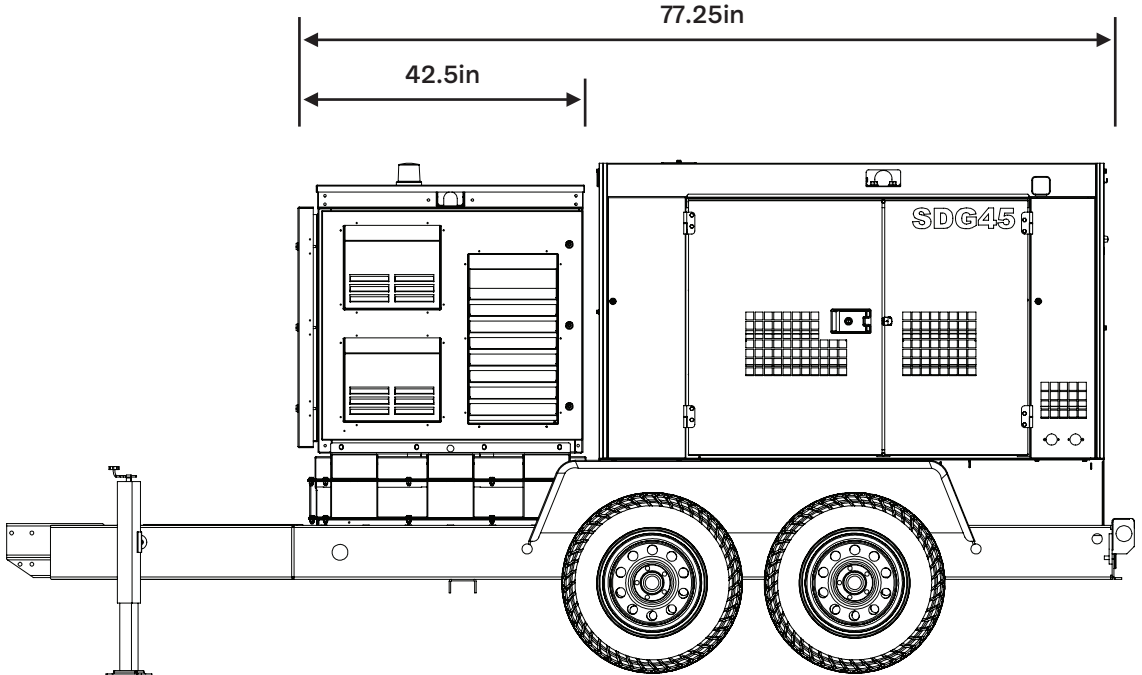
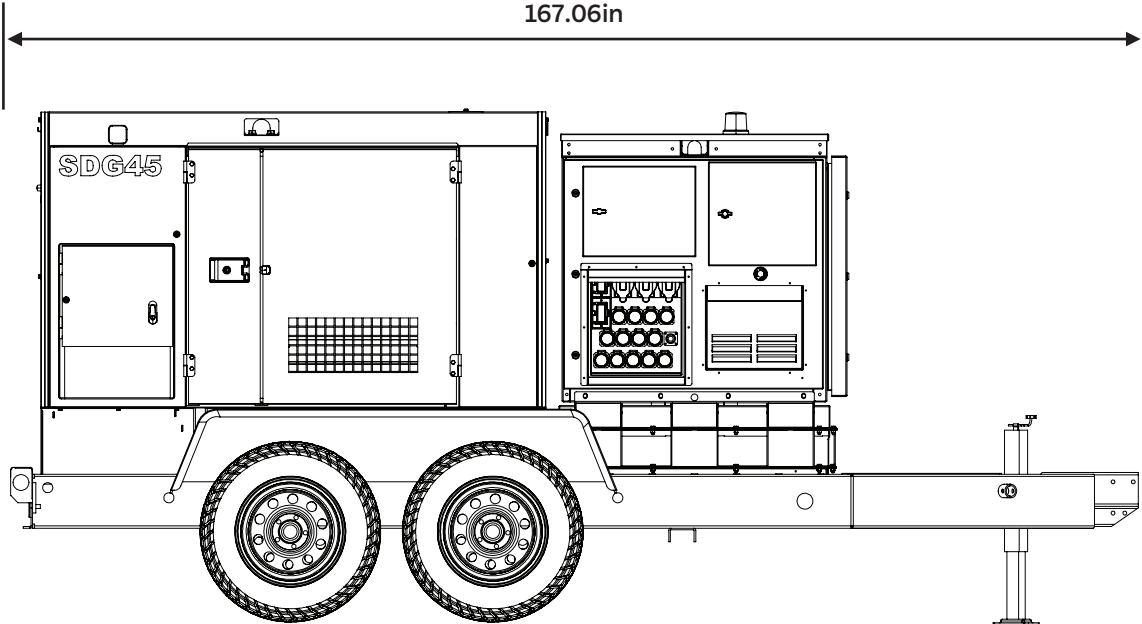

▶ EBOSS™ Dimensions

EBOSS™ 70kVA hybrid specifications.

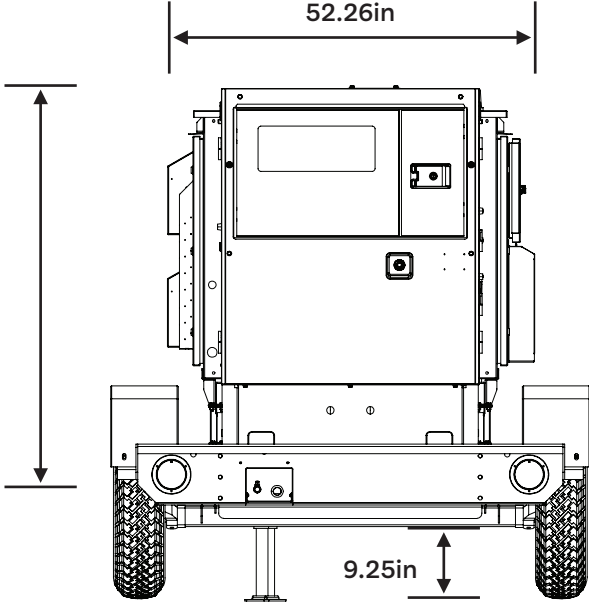
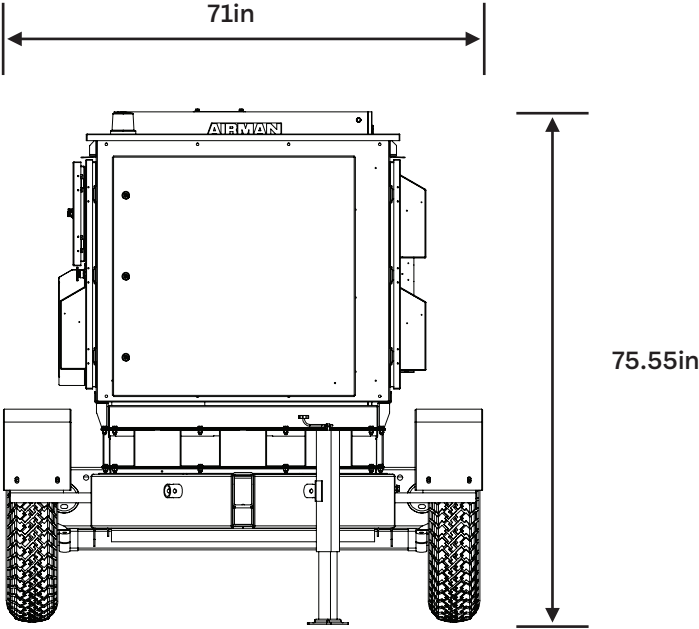

▶ EBOSS™ Decals

EBOSS™ 70kVA hybrid decal locations.

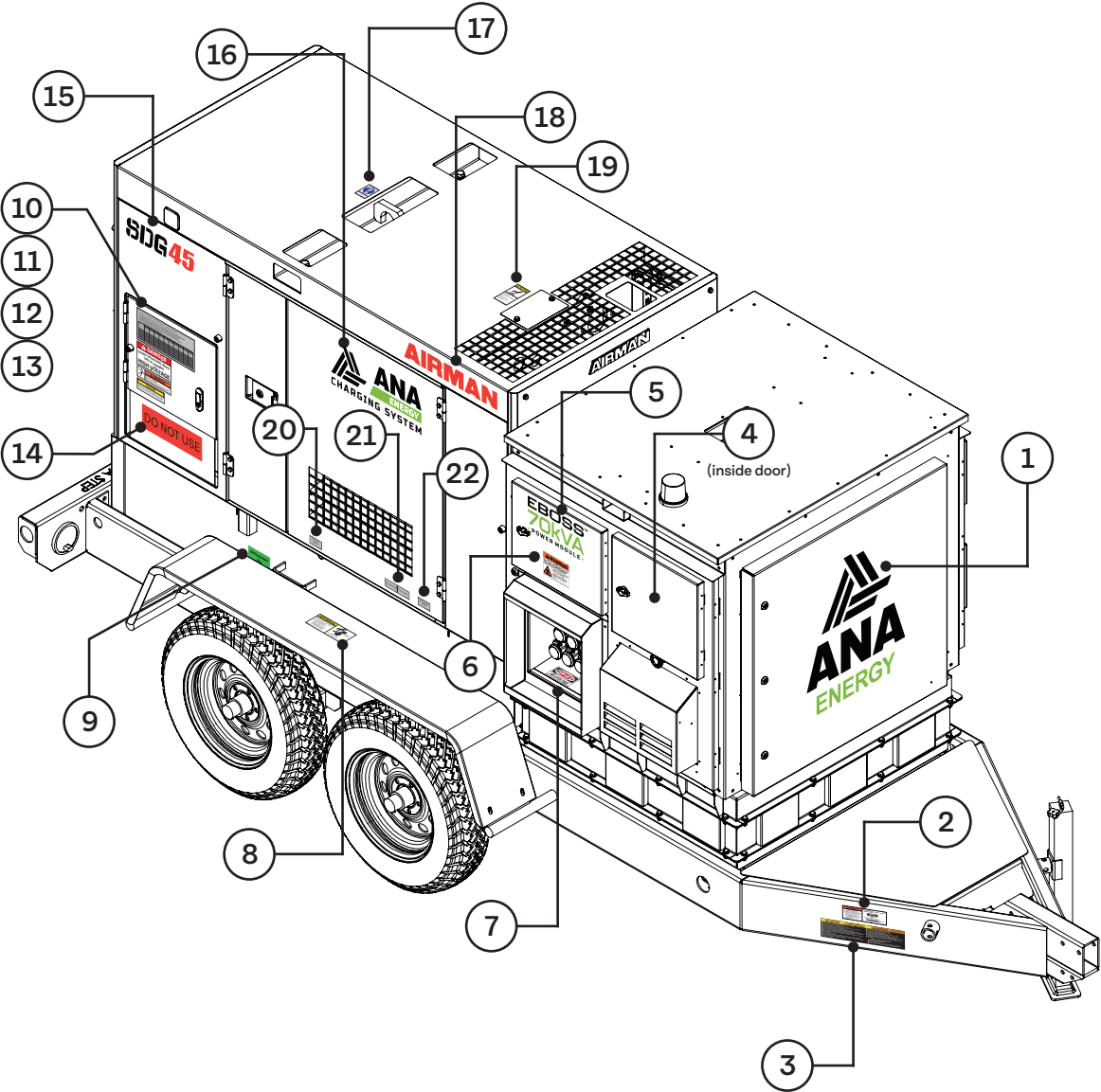

▶ EBOSS™ Decals

EBOSS™ 70kVA hybrid decal locations.

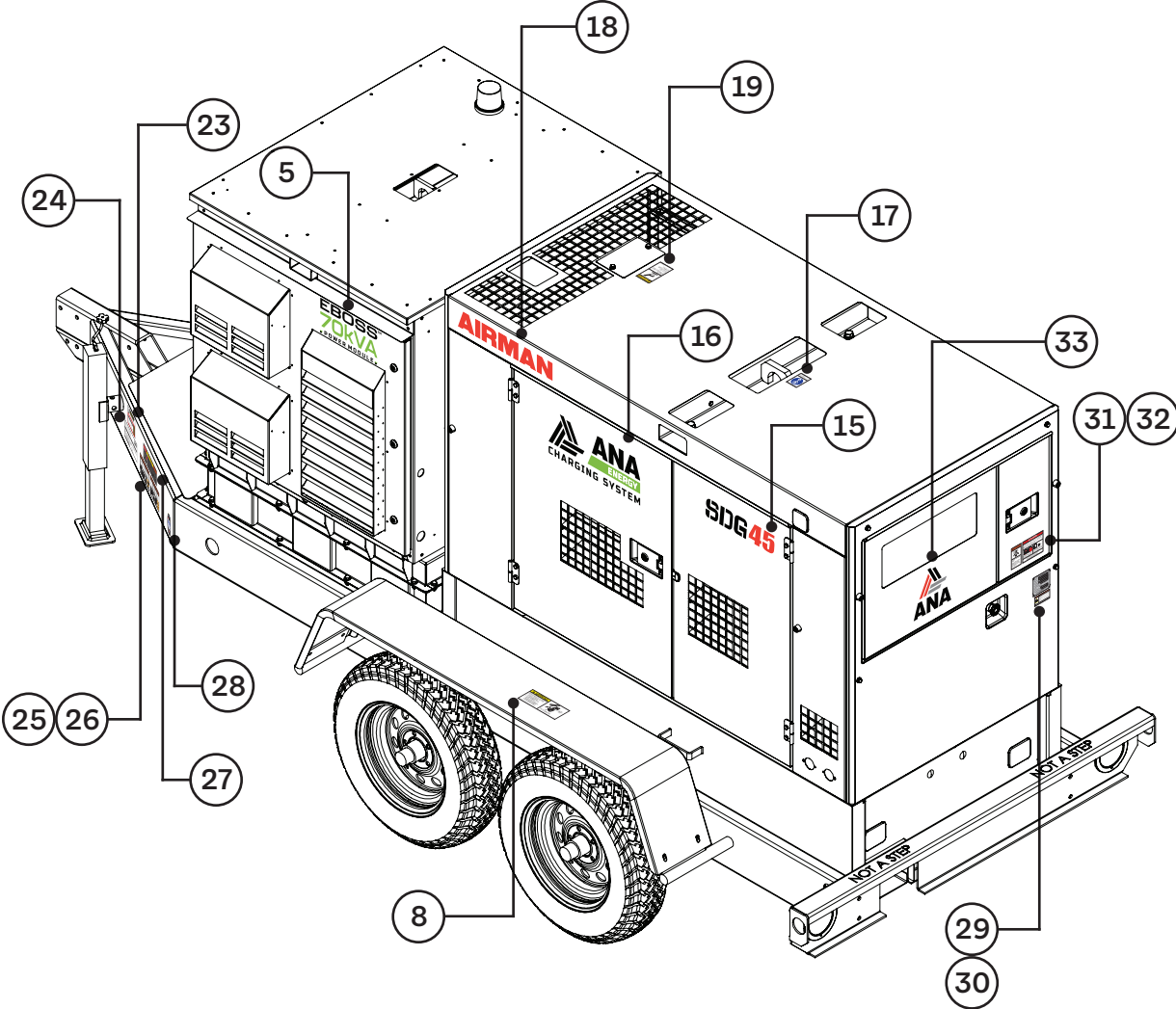

▶ EBOSS™ Decals

EBOSS™ 70kVA hybrid decal descriptions.

EBOSS™ Decals			
1	ANA Energy logo	18	Airman logo
2	Warning - Overload Hazard	19	Caution - Do Not Open Rad Cap
3	Safe Trailer Towing Guidelines	20	Radiator Drain Location
4	Quick Start Guide	21	Fuel Return / Inlet
5	EBOSS™ 70kVA logo	22	Radiator Drain
6	Danger - High Voltage	23	Tire & Loading Information
7	Warning - Arc Flash - PPE	24	Trailer VIN
8	Warning - Wheels & Lugnuts	25	Warning - Pintle Hitch
9	Ground Wire Location	26	Warning - Ball Hitch
10	Maximum Power Chart	27	Trailer Tow Warnings
11	Danger - Do Not Open Panel	28	NATM MFG Badge
12	Warning - Do Not Touch	29	Generator Data Plate
13	Caution - Power Distribution	30	Warning - Diesel Exhaust
14	Do Not Use	31	Warning - Exhaust Fumes
15	SDG45 logo	32	Danger - Carbon Monoxide
16	ANA Charging System logo	33	ANA logo (small)
17	Lift Point Location		

▶ EBOSS™ Decals

EBOSS™ 70kVA hybrid decals.

1



2

WARNING	MAXIMUM LOADED TRAILER WEIGHT (GVWR) = EQUALS
<p>OVERLOAD HAZARD RISK OF DEATH DUE TO LOSS OF CONTROL. NEVER EXCEED THE GROSS VEHICLE WEIGHT RATING (GVWR).</p> <ul style="list-style-type: none"> BEFORE LOADING THE TRAILER FOR THE FIRST TIME, YOU MUST VERIFY ITS CARGO CAPACITY. <ol style="list-style-type: none"> You MUST WEIGH the EMPTY TRAILER. Subtract the weight of the EMPTY TRAILER from the MAXIMUM LOADED TRAILER WEIGHT (GVWR) (see VIN / SERIAL NO. TAG) DO NOT LOAD TRAILER BEYOND VERIFIED CARGO CAPACITY. 	<p>MAXIMUM CARGO WEIGHT</p> <p>+ PLUS</p> <p>WEIGHT OF EMPTY TRAILER</p>

3

CAUTION	OPERATOR RESPONSIBILITY SAFE TRAILER TOWING GUIDELINES:	WARNING	<small>NOT FOLLOWING THESE SAFE TRAILER GUIDELINES CAN LEAD TO SERIOUS INJURY OR DEATH AND/OR PROPERTY DAMAGE.</small>
<ul style="list-style-type: none"> BEFORE TOWING CHECK COUPLING, SAFETY CHAIN, SAFETY BRAKE, TIRE INFLATION, WHEELS AND LIGHTS. USING A SPOTTER, BACK TOW VEHICLE UP TO TRAILER AND HOOK UP. AFTER CONNECTED TO TOW VEHICLE, MAKE SURE TRAILER IS LEVEL; ADJUST AS NEEDED. LOCK PARKING BRAKE OF TOW VEHICLE, BE SURE TRAILER IS ATTACHED, & USE WHEEL CHOCKS WHEN LOADING & UNLOADING. NEVER LEAVE TRAILER DISENGAGED FROM TOW VEHICLE WHEN LOADED. MAKE SURE DECK IS CLEAR OF ALL DEBRIS BEFORE LOADING AND BEFORE HEADING OUT ONTO THE ROAD. SECURE CARGO OR EQUIPMENT TO TRAILER; SECURE LOAD ON ALL FOUR CORNERS IF POSSIBLE. DO NOT OVER TIGHTEN BINDERS. RAMPS MUST BE UPRIGHT & SECURE DURING TOWING, DO NOT PUT HANDS & FEET UNDER RAMPS OR GATE WHEN RAISING OR LOWERING. RAMPS / GATES / DECK HAVE SLIPPERY SURFACES; USE EXTREME CAUTION IN WET OR MOIST CONDITIONS. ADJUST BRAKE CONTROLLER TO ENGAGE THE TRAILER BRAKES BEFORE THE TOW VEHICLE BRAKES. YOUR DEALER CAN ASSIST YOU BY MAKING THIS ADJUSTMENT. USE YOUR TURN SIGNALS WELL IN ADVANCE. USE YOUR MIRRORS TO VERIFY THAT YOU HAVE ROOM TO CHANGE LANES OR PULL INTO TRAFFIC, OR IF VISION IS OBSTRUCTED. ALLOW PLENTY OF ROOM FOR PASSING. THE PASSING DISTANCE WITH A TRAILER IS 4 TIMES THE PASSING DISTANCE WITHOUT A TRAILER. ALLOW PLENTY OF STOPPING SPACE FOR YOUR TRAILER AND TOW VEHICLE. NEVER DRIVE FASTER THAN 50 M.P.H. 	<ul style="list-style-type: none"> DO NOT DRIVE SO FAST THAT THE TRAILER BEGINS TO SWAY DUE TO SPEED. SHIFT YOUR AUTOMATIC TRANSMISSION INTO A LOWER GEAR FOR CITY DRIVING. USE LOWER GEARS FOR CLIMBING AND DESCENDING GRADES. DO NOT RIDE THE BRAKES WHILE DESCENDING GRADES; THEY MAY GET SO HOT THAT THE STOP WORKING. THEN YOU WILL POTENTIALLY HAVE A RUNAWAY TOW VEHICLE AND TRAILER. SLOW DOWN FOR BUMPS IN THE ROAD. TAKE YOUR FOOT OFF THE BRAKE WHEN CROSSING THE BUMP. DO NOT BRAKE WHILE IN A CURVE UNLESS ABSOLUTELY NECESSARY. INSTEAD, SLOW DOWN BEFORE YOU ENTER THE CURVE AND POWER THROUGH THE CURVE; THIS WAY THE TOWING VEHICLE REMAINS IN CHARGE. DO NOT APPLY THE BRAKES TO CORRECT EXTREME TRAILER SWAYING; STEER STRAIGHT AHEAD AND REMOVE YOUR FOOT FROM THE GAS. 	<p style="text-align: center;">ONCE EACH HOUR OR EVERY 50 MILES CONFIRM THAT</p> <ul style="list-style-type: none"> THE COUPLER IS SECURE TO THE HITCH AND IS LOCKED. ELECTRICAL CONNECTION ARE SECURE. THERE IS APPROPRIATE SLACK IN BOTH THE SAFETY CHAINS, AND THE BREAKAWAY SWITCH PULL PIN CABLE. THE TIRES ARE NOT VISIBLY LOW ON PRESSURE, AND THE CARGO IS SECURE AND IN GOOD CONDITION. 	

4

QUICK START GUIDE	
<p>START UP PROCEDURE</p> <ol style="list-style-type: none"> Before starting the Energy Boss, ground the Energy Boss, then ground the generator (see the generator manual for directions). On the generator, turn the control power switch to ON. Place generator into Auto Mode. Make sure the voltage selector is set to 480V. Connect the Orange Battery Disconnect (located directly on the battery packs beneath the unit) by twisting clockwise. (See Energy Boss manual for more information.) Switch the main generator breaker to ON. On the Energy Boss, firmly press the black button under the HMI control screen. The system will take around 30 seconds to power up. Connect load to correct voltage outputs and turn ON breakers for that load. Breakers on unused outlets should be OFF. Push the START button on the touch screen. Check output voltages and adjust voltage as needed. 	<p>SHUT DOWN PROCEDURE</p> <ol style="list-style-type: none"> Press STOP button on Energy Boss to stop the power output. Turn OFF the output breaker located within the breaker panel. To manually shut down, press FAILTS then press SHUT DOWN. The Control Screen will shut down automatically when the battery reaches 35%. On the generator, turn OFF the main breaker. On the generator, switch control power to OFF. <p>LONG TERM STORAGE PROCEDURE</p> <ol style="list-style-type: none"> Ensure the battery is at least 50% charged. Disconnect the Orange Battery Disconnect (located directly on the battery packs beneath the unit) by twisting counterclockwise and pulling out. (See Energy Boss manual for more information.)

5



▶ EBOSS™ Decals

EBOSS™ 70kVA hybrid decals.

6



7



8

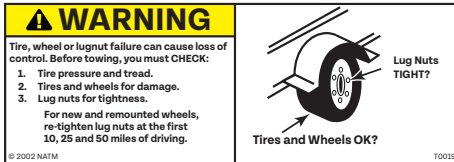

9



10

Never Exceed the Maximum Combined Simultaneous Power Consumption

The following chart shows the maximum power available from the 120V-20A GFCI receptacles during simultaneous consumption (main terminals and receptacles) for both single or three phase settings. Values shown in the left column give the maximum current available at the 120V-20A GFCI receptacles compared to the value of the simultaneous current consumption from the main terminals.

Single Phase 120V-20A GFCI Recept.	SDG255		SDG405		SDG455		SDG655		SDG1005	
	Three Phase 240/480V	Single Phase 240/120V	Three Phase 240/480V	Single Phase 240/120V	Three Phase 240/480V	Single Phase 240/120V	Three Phase 240/480V	Single Phase 240/120V	Three Phase 240/480V	Single Phase 240/120V
kW	kVA	kW	kVA	kW	kVA	kW	kVA	kW	kVA	kW
0.0	25.0	14.4	38.0	22.0	45.0	26.0	63.0	36.5	100	57.7
1.2	20.8	13.2	33.8	20.8	40.9	24.8	59.0	35.3	96.0	56.5
2.4	16.7	12.0	29.7	19.6	36.7	23.6	54.9	34.1	91.9	55.3
3.6	12.5	10.8	25.5	18.4	32.6	22.4	50.7	32.9	87.7	54.1
4.8	8.4	9.6	21.4	17.2	28.4	21.2	46.6	31.7	83.6	52.9

11



12



13



▶ EBOSS™ Decals

EBOSS™ 70kVA hybrid decals.

14



15

SDG45

16



17



18

AIRMAN

19

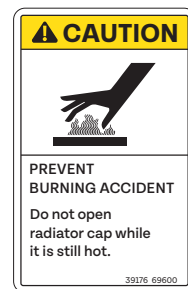

20

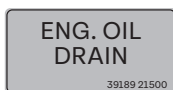

21



22



▶ EBOSS™ Decals

EBOSS™ 70kVA hybrid decals.

23

TIRE AND LOADING INFORMATION
RENSEIGNEMENTS SUR LES PNEUS ET LE CHARGEMENT

The weight of cargo should never exceed
2,790 kg or 6,150 lbs.

7H6BX14B6RH001435

TIRE	SIZE	COLD TIRE PRESS.
FRONT	ST205/75R-15D	448 KPA (65 PSI)
INTER	NONE	NONE
REAR	ST205/75R-15D	448 KPA (65 PSI)
SPARE	NONE	NONE

SEE OWNER'S MANUAL FOR ADDITIONAL INFORMATION
VOIR LE MANUEL DE L'USAGER POUR PLUS DE RENSEIGNEMENTS

24

MANUFACTURED BY: ALLIANCE NORTH AMERICA, INC.

DATE OF MFG : 08/2024 GVWR: 3357 KG (7400 LB)

GAWR (EACH AXLE)	WITH TIRES	RIMS AT	COLD
1678 KG (3700 LB)	ST205/75R-15D	15" X 5"	448 KPA (65 PSI) DUAL

THIS VEHICLE CONFORMS TO ALL APPLICABLE U.S. FEDERAL MOTOR VEHICLE SAFETY STANDARDS IN EFFECT ON THE DATE OF MANUFACTURE SHOWN ABOVE

V.I.N. : **7H6BX14B6RH001435** TYPE : TRAILER
EBOSS 70-25

25

⚠ WARNING	⚠ WARNING	⚠ WARNING	⚠ WARNING
<p>Uncoupling will cause trailer to come loose from tow vehicle.</p> <p>1. CHECK that pin's LOAD RATING is same or greater than ring LOAD RATING.</p> <p>2. LOCK the clamp on place using a pin or lock.</p>	<p>ALWAYS use safety chains. Chains hold trailer if connection fails. You must:</p> <p>1. CROSS chains underneath coupler.</p> <p>2. ALLOW slack for trailer to turn.</p> <p>3. ATTACH chain hooks securely to tow vehicle frame.</p>	<p>Trailer can roll if it comes loose. Electric safety brake applies when cable pulls pin out of switch box:</p> <p>1. PULL hard to get pin out of switch box.</p> <p>2. CHECK brake by PULLING TRAILER with tow vehicle.</p> <p>3. ATTACH pin CABLE to tow vehicle so pin will be pulled out if trailer separates.</p> <p>4. Promptly REPLACE pin in switch box.</p>	<p>Lights can prevent trailer from being hit by other vehicles. You must:</p> <p>1. CONNECT trailer and tow vehicle electrical connectors.</p> <p>2. CHECK all lights: tail lights, turn signal, and brake lights.</p> <p>3. DO NOT TOW if lights are not working.</p>

26

⚠ WARNING	⚠ WARNING	⚠ WARNING	⚠ WARNING
<p>ALWAYS use safety chains. Chains hold trailer if connection fails. You must:</p> <p>1. CROSS chains underneath coupler.</p> <p>2. ALLOW slack for trailer to turn.</p> <p>3. ATTACH chain hooks securely to tow vehicle frame.</p>	<p>Uncoupling will cause trailer to come loose from tow vehicle. You must:</p> <p>1. CHECK that ball LOAD RATING is same or greater than coupler LOAD RATING.</p> <p>2. CHECK that ball SIZE is same as coupler.</p> <p>3. CLOSE COUPLER CLAMP on ball.</p> <p>4. LIFT coupler upwards to test that it will not separate from ball.</p> <p>5. LOCK coupler clamp with pin or padlock.</p>	<p>Trailer can roll if it comes loose. Safety brake applies when chain pulls brake lever:</p> <p>1. ATTACH brake CHAIN to tow vehicle so lever will pull out if trailer separates.</p> <p>2. CHECK brake fluid level.</p> <p>3. DO NOT TOW trailer if brake fluid level is NOT FULL.</p>	<p>Lights can prevent trailer from being hit by other vehicles. You must:</p> <p>1. CONNECT trailer and tow vehicle electrical connectors.</p> <p>2. CHECK all lights: tail lights, turn signal, and brake lights.</p> <p>3. DO NOT TOW if lights are not working.</p>

▶ EBOSS™ Decals

EBOSS™ 70kVA hybrid decals.

27

⚠ DANGER	⚠ CAUTION	BEFORE TOWING THIS TRAILER CHECK THAT:	⚠ WARNING
SERIOUS INJURY AND/OR PROPERTY DAMAGE CAN RESULT IF THIS VEHICLE IS TOWED BEFORE FAMILIARIZING YOURSELF WITH THE MANUFACTURER'S OPERATING INSTRUCTIONS AND CAUTIONS LISTED TO THE RIGHT.	<ul style="list-style-type: none"> • COUPLER HITCH AND TRAILER BALL ARE THE SAME SIZE. • COUPLER IS LATCHED. • SAFETY CHAINS ARE CRISSCROSSED UNDER TONGUE AND ATTACHED TO TOWING VEHICLE. • ALL TRAILER LIGHTING IS WORKING CORRECTLY. • LOAD IS SECURED TO TRAILER FRONT AND REAR. • TONGUE JACK (IF TRAILER IS EQUIPPED) IS RETRACTED. • TILT PIN IS LATCHED. • WHEEL LUG BOLTS ARE PROPERLY TIGHTENED. • TIRES ARE INFLATED TO PRESSURE INDICATED ON TIRE. • TRAILER BRAKES (IF TRAILER IS EQUIPPED) ARE PROPERLY ADJUSTED AND BREAK-AWAY DEVICE IS ATTACHED TO TOWING VEHICLE. • LOAD IS WITHIN TRAILER CAPACITY AND DISTRIBUTED PROPERLY TO MAINTAIN PROPER TONGUE WEIGHT. 	<ul style="list-style-type: none"> • COUPLER IS LATCHED. • SAFETY CHAINS ARE CRISSCROSSED UNDER TONGUE AND ATTACHED TO TOWING VEHICLE. • ALL TRAILER LIGHTING IS WORKING CORRECTLY. • LOAD IS SECURED TO TRAILER FRONT AND REAR. • TONGUE JACK (IF TRAILER IS EQUIPPED) IS RETRACTED. • TILT PIN IS LATCHED. • WHEEL LUG BOLTS ARE PROPERLY TIGHTENED. • TIRES ARE INFLATED TO PRESSURE INDICATED ON TIRE. • TRAILER BRAKES (IF TRAILER IS EQUIPPED) ARE PROPERLY ADJUSTED AND BREAK-AWAY DEVICE IS ATTACHED TO TOWING VEHICLE. • LOAD IS WITHIN TRAILER CAPACITY AND DISTRIBUTED PROPERLY TO MAINTAIN PROPER TONGUE WEIGHT. 	YOU ARE REQUIRED TO COMPLY WITH LOCAL AND STATE REQUIREMENTS REGARDING BRAKES, LICENSING AND ANY ADDITIONAL EQUIPMENT THAT MAY BE NECESSARY. CONTACT YOUR STATE MOTOR VEHICLE DEPARTMENT FOR MORE INFORMATION.

28



29

ENGINE GENERATOR	
MODEL	SDG45S-8E2
SER. NO.	123A456B789C
GEN. OUTPUT	45 kVA
VOLTAGE	240/480 V
FREQUENCY	60 Hz
POWER FACTOR	80% PHASE 3
RULE	JEM1398
NET DRY MASS	1060 kg
OPERATING MASS	1340 kg
AIRMAN USA CORPORATION ASSEMBLED IN USA 30303 49800	



30

⚠ WARNING
 <p>Breathing diesel engine exhaust exposes you to chemicals known to the State of California to cause cancer and birth defects or other reproductive harm.</p> <ul style="list-style-type: none"> • Always start and operate the engine in a well-ventilated area. • If in an enclosed area, vent the exhaust to the outside. • Do not modify or tamper with the exhaust system. • Do not idle the engine except as necessary. <p style="font-size: x-small;">For more information go www.P65warnings.ca.gov/diesel 39178 67840</p>

31

⚠ WARNING
 <p>BEWARE OF EXHAUST GASES</p> <p>When you operate machine INDOORS or in TUNNEL, provide good ventilation. Poor ventilation can cause fatal accident.</p> <p style="font-size: x-small;">39176 73300</p>

32

⚠ DANGER
<p>Using a generator indoors CAN KILL YOU IN MINUTES. Generator exhaust contains carbon monoxide. This is a poison you cannot see or smell.</p> <div style="display: flex; justify-content: space-around;"> <div style="text-align: center;">  <p style="font-size: x-small;">NEVER use inside a home or garage, EVEN IF doors and windows are open.</p> </div> <div style="text-align: center;">  <p style="font-size: x-small;">Only use OUTSIDE and far away from windows, doors, and vents.</p> </div> </div> <p style="font-size: x-small;">Avoid other generator hazards. READ MANUAL BEFORE USE. 39176 09310</p>

33



► Safety - Explanations and Symbols

Read this manual thoroughly and make sure you understand the procedures before you attempt to install, set up, or operate the ANA EBOSS™. Operating and servicing any part of the EBOSS™ requires Personal Protective Equipment (PPE) such as High Voltage gloves rated up to 1000V, Protective Eyewear, and Non Conductive Shoes. Do not touch anything without confirming with a Voltmeter the unit is safe to touch.

Warning - Hazardous High Voltage



Motor control equipment and electronic controllers are connected to hazardous line voltages. When servicing drives and electronic controllers, there may be exposed components with housings or protrusions at or above line potential. Extreme care should be taken to protect against shock.

Warning - Hazardous High Voltage



- Stand on an insulating pad and make it a habit to use only one hand when checking components.
- Always work with another person in case an emergency occurs.
- Disconnect power before checking controllers or performing maintenance.
- Be sure equipment is properly grounded.
- Wear safety glasses whenever working on electronic controllers or rotating machinery.

Warning - Hazardous High Voltage



Be sure to ground the unit following the instructions in this manual. Ungrounded units may cause electric shock and/or fire.

Warning - Hazardous High Voltage



This equipment should be installed, adjusted, and serviced by qualified electrical maintenance personnel familiar with the construction and operation of this type of equipment and the hazards involved. Failure to observe this precaution could result in death or severe injury.

Warning - Hazardous High Voltage



An upstream disconnect/protective device must be provided as required by the National Electric Code (NEC). Failure to follow this precaution may result in death or severe injury.

Caution - Equipment Damage



Any electrical or mechanical modification to this equipment without prior written consent of ANA will void all warranties and may result in a safety hazard and voiding of the UL listing.

Caution - Equipment Damage



Do not perform any meggar or voltage withstand tests on any part of the SBP Drive or its components. Improper testing may result in damage.

Caution - Equipment Damage



Prior to any tests or measurements of the motor or the motor cable, disconnect the motor cable at the SBP output terminals (U, V, W) to avoid damaging the SBP during motor or cable testing.

Caution - Equipment Damage



Do not touch any components on the circuit boards. Static voltage discharge may damage the components.

Caution - Equipment Damage



Prevent foreign material such as wire clippings or metal shavings from entering the drive or controller enclosure, as this may cause arcing damage and fire.

► Definitions and Acronyms

The following terms and acronyms are used throughout this manual to describe the functions and operation of the EBOSS™. Please reference this page if you need any clarification as you read through this operation manual.

SOC - State of Charge.

DC - Direct Current.

AC - Alternating Current.

Converter - Rectifier circuit used to convert AC to DC. The DC from the converter is called the DC bus voltage.

DC Bus - Resulting voltage in the circuit from the converted AC voltage after the rectifier circuitry.

IGBT - Insulated Gate Bipolar Transistor.

Inverter - IGBT circuit configured to change DC bus voltage to AC of varying frequencies through pulse width modulation (PWM).

Battery Storage System - Group of batteries used to store the required amount of voltage (energy) for operation of the EBOSS™.

Generator - Converts motive power into electrical power for use in an external circuit via diesel motor.

HMI - Human Machine Interface, control screen.

Telematics - Telematics is a system of software and hardware elements that allows:

- Control industrial processes locally or at remote locations.
- Monitor, gather, and process real-time data.
- Directly interact with devices such as sensors, valves, pumps, and motors through human-machine interface (HMI) software.

▶ **Transportation on a Flatbed**

EBOSS™ must be loaded or unloaded using the correct equipment operated by trained personnel. ANA offers no direct support for untrained individuals carrying out any action on the unit. The unit must remain upright at all times. Contact ANA Support to request training.

Warning - Equipment Damage



- The EBOSS™ can be transported using a trailer or goods vehicle with adequate available payload. Check the relevant transportation documentation for suitability.
- The gross weight of the unit can be found on the rating plate positioned on the central front door.
- It is recommended that the unit is secured using suitable straps when in transit to prevent it from moving.
- Unit must be switched off through the EBOSS™ HMI System switch button on home tab.
- Check that the emergency stop button is not engaged by twisting it clockwise.

▶ **Loading and Unloading**

The EBOSS™ weighs over 6,600lbs with fuel and accessories. A forklift or crane with the proper lift capacity is required to safely load or unload the EBOSS™.

Once loaded on a flat bed, utilize the 4 tie downs on the underside of the trailer frame to secure the EBOSS™ to bed of a truck or trailer.

► Overhead Lifting - Anchor Points

The EBOSS™ may be lifted using a spreader bar connected to the anchor points or lifting bails on the EBOSS™ and the generator. Initially, apply partial load and check proper rotation and alignment. There should be no interference between the load (EBOSS™) and the anchor point bail.

Never use an anchor point that shows signs of corrosion, wear or damage. Never use an anchor point if the bail is bent or elongated.

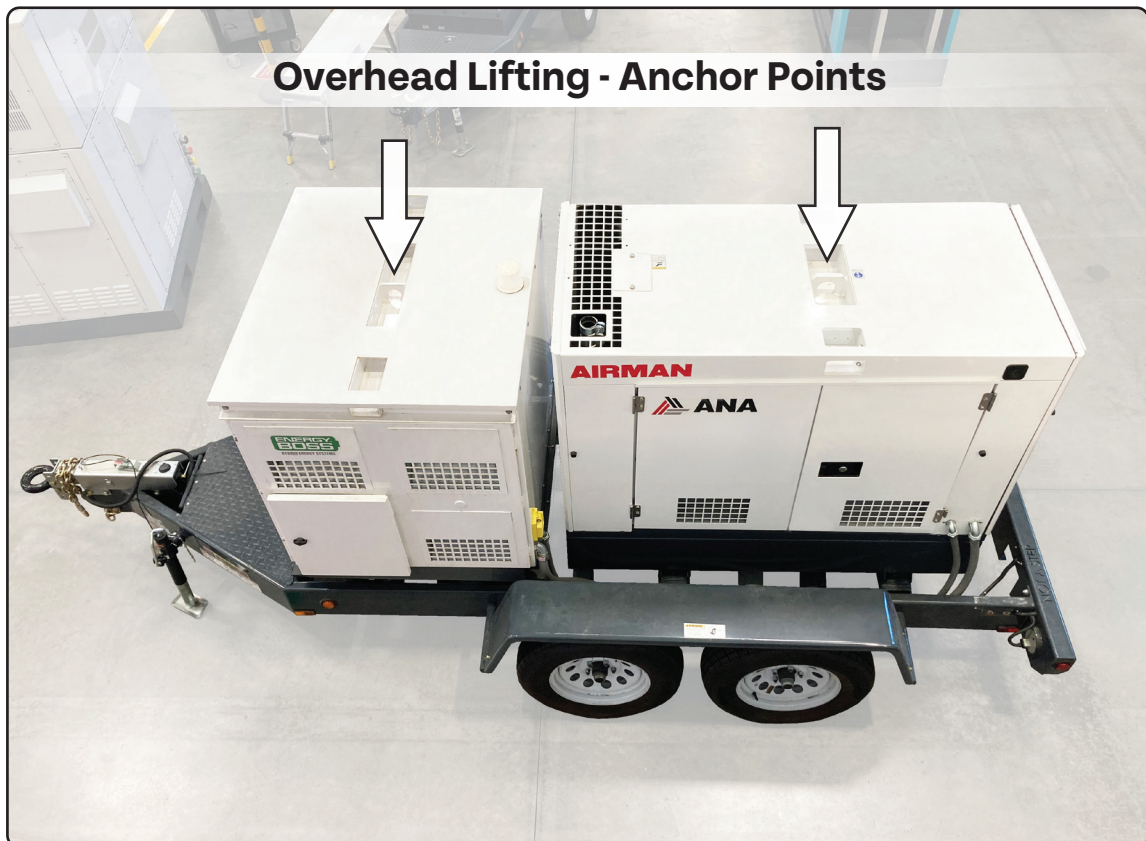

► Lifting Locations - Forklift

Fork lift locations are located behind the rear axle and in front of the front axle for balanced lifting.

▶ Tie Down Locations

There are 4 tie down locations on the EBOSS™. These tie down locations are designed to secure the EBOSS™ to a flatbed trailer for transport only.

Do not use these tie down locations to lift, tow, reposition, or otherwise move the EBOSS™. These tie down locations are not designed to withstand vertical or horizontal forces beyond securing the EBOSS™ to a flatbed trailer for transport.



► Unloading

- 1) Remove tiedowns or chains securing the EBOSS™ to the trailer. Carefully approach the EBOSS™ with a properly rated forklift.



- 2) Position forks to lift behind the rear axle and forward of the front axle to balance the load. Slowly raise the forks until making contact with the EBOSS™. Carefully lift the EBOSS™ up off the trailer.



► Unloading (cont)

3) Once raised, carefully back away from the trailer to allow sufficient clearance to lower the EBOSS™. Be aware of your surroundings and use a spotter if available to assist you.



4) Slowly lower the forks, placing the EBOSS™ on the ground. Lower the forks a few more inches, so they fully clear the EBOSS™. Carefully back the forklift away from the EBOSS™.



▶ Loading

1) Carefully approach the EBOSS™ with a properly rated forklift. Fork lift locations are located behind the rear axle and in front of the front axle for balanced lifting.



2) Slowly raise the forks until making contact with the EBOSS™. Carefully lift the EBOSS™ up off of the ground. Ensure the EBOSS™ is balanced on the forks.



► Loading (cont)

3) Raise the EBOSS™ up high enough to clear the trailer. Slowly approach the trailer, using a spotter to assist you if available. Position the EBOSS™ in the middle of the trailer.



4) Carefully lower the EBOSS™ onto the flatbed trailer. Lower the forks slowly to ensure the load is stable on the trailer. Once forks are clear of the EBOSS™, slowly back forklift away from the trailer.



► Securing to a Flatbed

Once the EBOSS™ has been loaded on a flat bed, utilize the 4 tie downs on the underside of the trailer frame to secure the EBOSS™ to the trailer.



Tie down locations are located in front of the front axles (2) and behind the rear axles (2). These are designed for tie down only and are not designed for lifting the EBOSS™.



▶ Towing the EBOSS™

The EBOSS™ can be towed using a properly rated tow vehicle. With the EBOSS™ weighing more than 6,600lbs, the driver of the tow vehicle should be familiar with towing heavy loads.



Warning - Equipment Damage



- The EBOSS™ can be transported using a vehicle with adequate available towing capacity. Check the tow vehicle's owners manual or tow rating for the correct information.
- The gross weight of the unit can be found on the rating plate positioned on the central front door.
- Unit must be switched off through the EBOSS™ HMI System switch button on home tab.
- Check that the emergency stop button is not engaged by twisting it clockwise.

▶ Attaching the Hitch

The EBOSS™ can be towed with a properly rated vehicle that has a correctly installed pintle hitch and lunette ring connections.

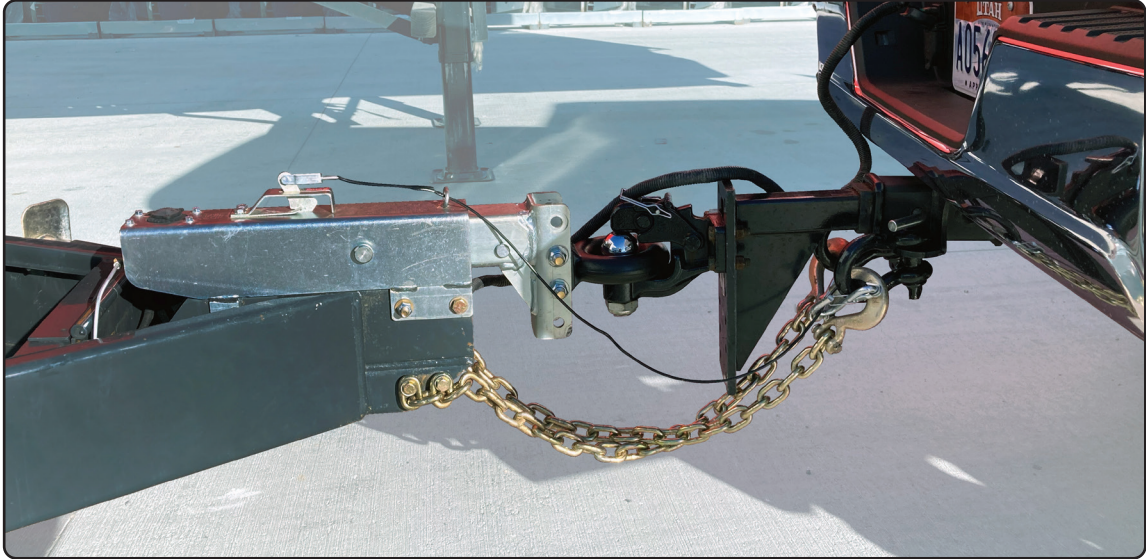

Attach the Pintle Hitch

- 1)** Using the trailer jack, raise the lunette ring coupler high enough to clear the pintle hitch on the tow vehicle.
- 2)** Remove the locking pin and lift the pintle hitch latch. Back up the tow vehicle (use a spotter if available) to position the pintle hitch directly under the lunette ring.
- 3)** Using the trailer jack, lower the trailer and lunette ring coupler onto the pintle hitch hook on the tow vehicle. Close and lock the pintle hitch latch and insert the latch pin.
- 4)** Fully retract the trailer jack. Attach tow chains to the tow vehicle.
- 5)** Connect the trailer wiring connector and emergency brake cable to the tow vehicle.
- 6)** Check the trailer brake lights and running lights for proper operation and visibility.

► Inspecting the Trailer and Tow Vehicle

The EBOSS™ trailer and tow vehicle should be thoroughly inspected before every trip.



Pre-Trip Inspection Checklist

- 1) Check the trailer has been attached correctly and the running and brakes lights are operating properly and visible.
- 2) Ensure the trailer tires are properly inflated and have sufficient tread depth, and the trailer wheels are torqued to the correct values.
- 3) Check that the trailer has the correct license plate, registration, and proper DOT documentation.
- 4) Check that the tow vehicle is in good condition (especially tires and brakes) and is properly equipped to tow the EBOSS™.

Safe Towing Guidelines

- 1) Do not exceed 55mph when towing on paved roads or 15mph on unpaved roads.
- 2) Drive cautiously and reduce travel speed in order to travel, turn, and stop safely.

► Fueling and Grounding

Fill the fuel tank on the generator before initial start-up. Ensure the generator is properly grounded per the manufacturer's operation manual instructions.



Ensure that the generator is grounded to specifications outlined in the generator's user manual. Failure to properly ground the generator may result in damage to the EBOSS™ and poses a safety risk to users.

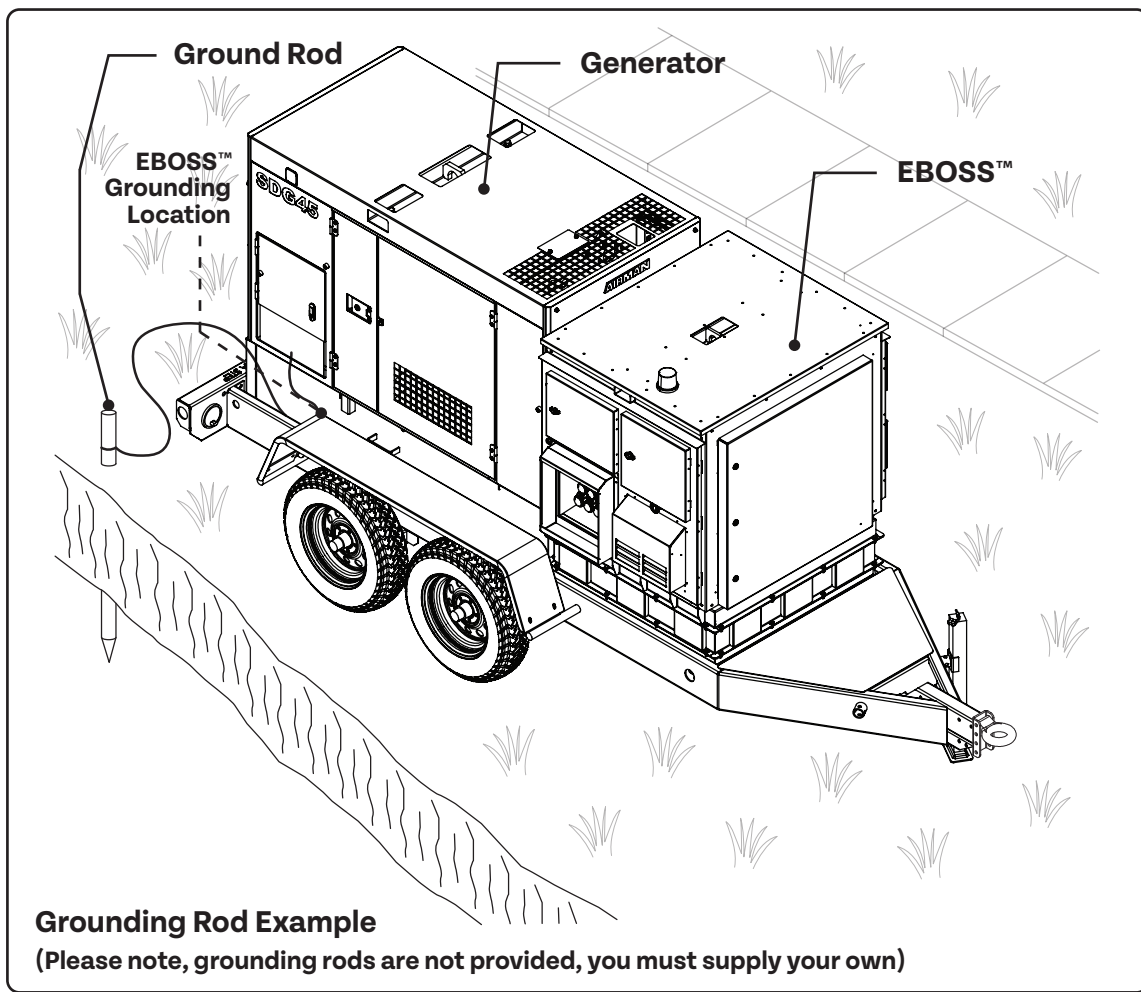

► Setup for Operation

The EBOSS™ is a Hybrid Energy System that combines a Generator with an Energy Storage system that maximizes the use of fuel and reduces generator run time. The system only runs the generator at full load when charging the EBOSS™, which is the most efficient use of the generator in terms of gallons per kW.

The home screen (HMI) shows the direction of power flow. The EBOSS™ uses three inverters to route power between the generator, the battery storage system, and the loads.

AFE Inverter - Takes AC power from the generator and converts the load to the DC Bus.

Grid Converter - Converts the DC Bus to usable AC power, to supply the load.

DC/DC Inverter - Takes voltage from the DC Bus to charge the battery storage system.

Charging the EBOSS™

The generator charges the EBOSS™ battery. Once the battery is fully charged, the generator shuts off.

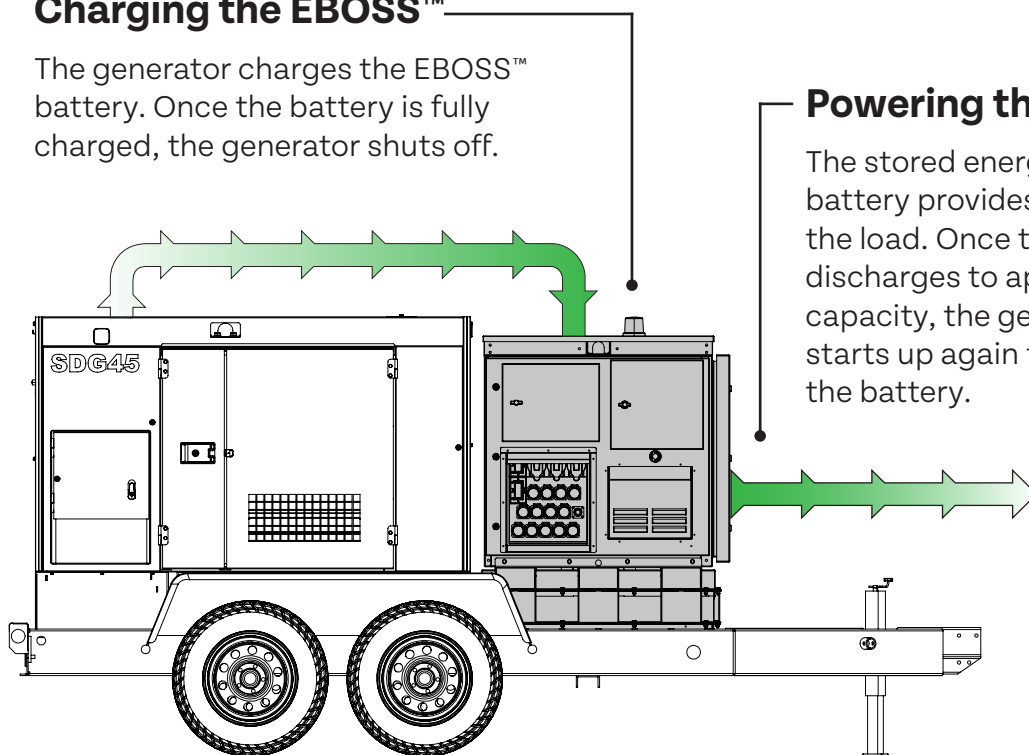

Powering the Load

The stored energy in the battery provides power to the load. Once the battery discharges to approx 15% capacity, the generator starts up again to charge the battery.

▶ Start Up Procedure

- 1) Before starting the EBOSS™, ground the generator.
- 2) On generator, turn control power switch to “ON.”
- 3) Press “**AUTO**” button to place generator in auto mode.
- 4) Adjust voltage selector to 480V if needed.
- 5) Switch main generator breaker to “ON.”
- 6) On EBOSS™, firmly press black button under control screen until screen fully turns on.
- 7) Turn on the main breaker located within EBOSS™ breaker panel.
- 8) Connect load to correct voltage outlets and turn on breakers for that load. Breakers on unused outlets should be off.
- 9) Push the “**PUSH TO START**” button on the touch screen.
- 10) Check output voltages, “adjust voltage” as needed.

▶ Shut Down Procedure

- 1) Press the “**PRESS TO STOP**” button on the touch screen to stop the EBOSS™ output.
- 2) Turn off the main breaker located within EBOSS™ breaker panel.
- 3) Navigate to the “**FAULTS**” page and press “**SHUTDOWN**” in the top right corner.
- 4) On the generator, turn the control power switch to “**OFF**.”

▶ **Connecting EBOSS™ Power Module to Generator** (only if using EBOSS™ with a non-standard hybrid energy system)

- 1) Before starting the EBOSS™, ground the generator.
- 2) Connect 3 Phase 480V AC Cam Lock connections from generator to EBOSS™ input (L1, L2, L3, Ground). 480V color scheme is brown, orange, yellow, and green.
- 3) Connect AutoStart (or GenStart) A1, A2 connections (low voltage wiring, 12V signal pulse) from generator to EBOSS™.
- 4) Turn generator control power “**ON**”. Ensure generator is placed into auto mode.
- 5) Adjust voltage selector to 480V if needed.
- 6) Switch main generator breaker to “**ON**.”
- 7) On EBOSS™, firmly press black button under control screen until screen fully turns on.
- 8) Turn on the main breaker located within EBOSS™ breaker panel.
- 9) Connect load to correct voltage outlets and turn on breakers for that load. Breakers on unused outlets should be off.
- 10) Push the “**PUSH TO START**” button on the touch screen.
- 11) Check output voltages, “adjust voltage” as needed.

▶ **Shut Down Procedure**

- 1) Press the “**PRESS TO STOP**” button on the touch screen to stop the EBOSS™ output.
- 2) Turn off the main breaker located within EBOSS™ breaker panel.
- 3) Navigate to the “**FAULTS**” page and press “**SHUTDOWN**” in the top right corner.
- 4) On the generator, turn the control power switch to “**OFF**.”

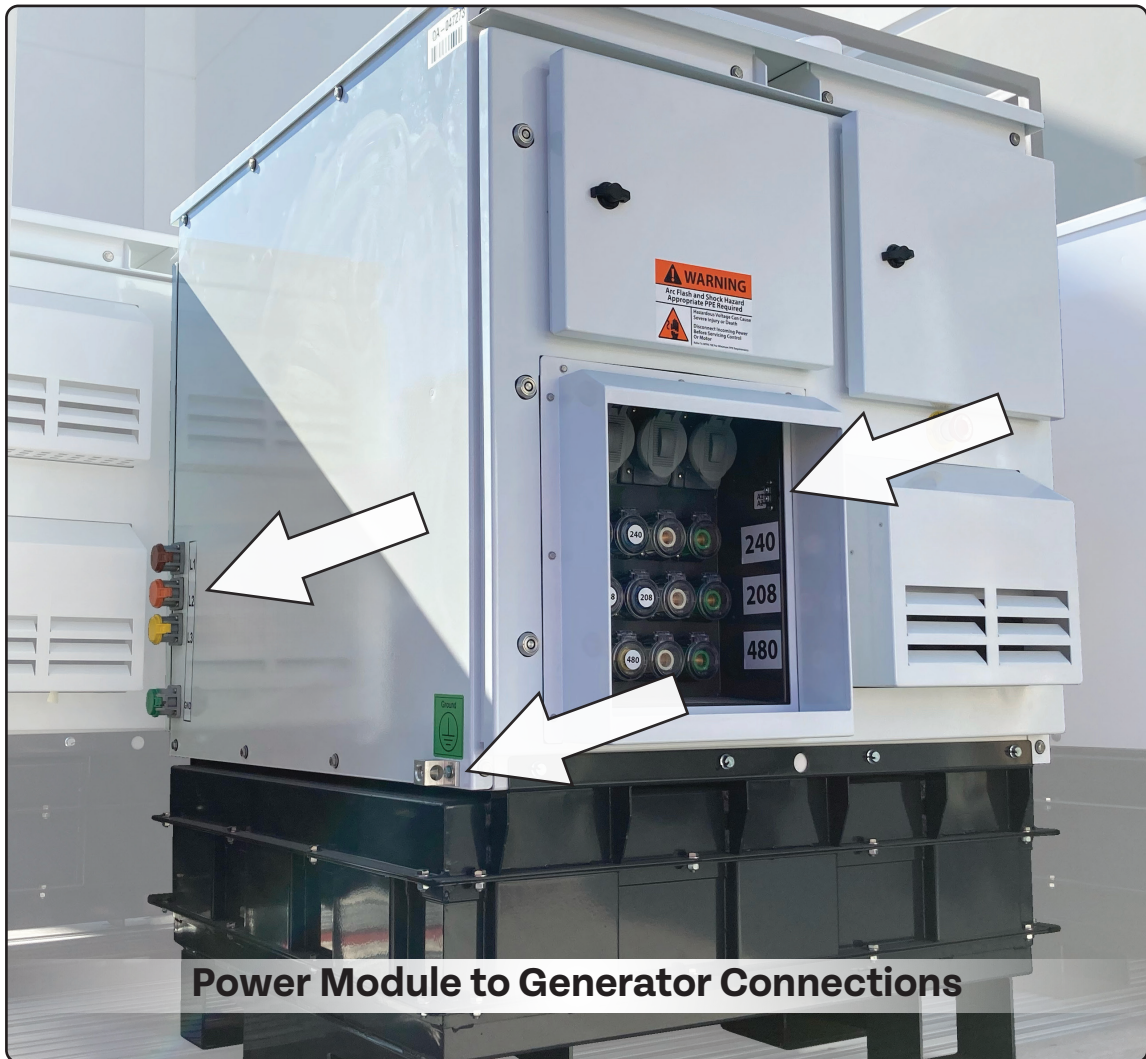

► **Compatible Generator Requirements** (only if using EBOSS™ with a non-standard hybrid energy system)

- 1)** The connected generator's internal battery must be in good condition and hold enough charge to run continuously for at least 12 hours.
- 2)** The connected generator should also include a trickle battery charger or solar charger.
- 3)** The EBOSS™ 70kVA power module must be connected to a 3-Phase, 480V generator capable of at least 35kW of output power.

▶ Power Sources

The EBOSS™ has the following power connection options:

- 3-Phase 480V (1 - connection, Cam Loks)
- 3-Phase 208V (1 - connection, Cam Loks)
- 1-Phase 240V (4 - connections, 3 Twist Locks* and 1 Cam Lok)
- Single Phase 120V (4 - outlet connections)*

*The main 240V breaker must be on while in use.



The combined output of each leg at 480V is 18.5kW. Thus, ensure legs are balanced as much as possible to ensure reliable operation. Connecting 3 phase power to a spider box panel and multiple spider boxes can isolate one of the legs and cause one of the legs to be over the 18.5kW limit.



▶ Batteries

The ANA lithium battery system is a high power, ultra-high cycle life system built for a wide number of commercial and industrial applications. Operation of the battery is fully automated and it shouldn't require any maintenance or servicing.

EBOSS™ 70kVA Battery Specs	
Energy Rating	25kWh
Max Voltage	648V
Min Voltage	360V
Typical High Voltage	610V
Typical Low Voltage	415V
Chemistry	Lithium Titanate Oxide

All lithium-ion batteries are susceptible to fluctuations in temperature, but the ANA battery system used in this application is much less sensitive than other batteries. Standard operating temperature range is -30°C to 55°C (-22°F to 130°F).

The batteries always have live voltage. A service disconnect is used in the system in order to provide a means of disconnection in the middle of the battery pack string. This means that, when disconnected, positive and negative high voltage battery leads are not in electrical continuity with each other.



Completely turning off the EBOSS™ and generator is required before removing the service disconnect (see image on pg 57). Ensure the service disconnect is twisted off completely and placed away from the mating connector to avoid making contact.

▶ Operation Sequence

EBOSS™ Sequence of Operation

- 1)** After preparing the generator (unit is fueled and properly grounded, voltage set to 480V, and controller placed in AUTO), the EBOSS™ is now ready to operate.
- 2)** On the EBOSS™, push and hold down black button under control screen until screen fully turns on (up to 30 seconds).
- 3)** Press the green start button on the home screen to open a pop-up window that asks you to confirm you have read the manual and are ready to start the EBOSS™.
- 4)** After confirmation, the system will come online. This takes approximately 2 minutes for the output panel to be live and have power. The generator will start up and begin to charge the batteries to the max capacity while powering the output load.
- 5)** Open breakers on any unused outputs.
- 6)** Once the battery is fully charged, the generator will shut off.
- 7)** The batteries will carry the electrical load until the batteries deplete. When this happens, the EBOSS™ will then send a command to start the generator and repeat the cycle.
- 8)** When the red stop button is pressed, output power stops and all contactors are open. If the generator is running at this time, the generator has a one minute cool down period before it shuts down. Do Not hit the E-Stop; allow the generator to cool down properly.
- 9)** The EBOSS™ has a built in timer to turn off the HMI if the battery pack is below approximately 35%, and the EBOSS™ is not running. It is best practice to let the batteries fully charge before performing a shutdown. This ensures the EBOSS™ batteries are less likely to be depleted before the next use.

10) To fully shutdown the EBOSS™, press the FAULTS button on the home screen and the SHUTDOWN button on the FAULTS page.

11) Remember to turn off the control power switch on the generator and open the main breaker to prevent unnecessary battery drain on the generator.

▶ **Cold Weather Operation**

Important Notes

1) The EBOSS™ can operate at temperatures as low as -22°F (-30°C) as long as it is powering a load and the generator is equipped with a cold weather package. Operating temperature is much lower than the cold start temperature.

2) Once operational, the EBOSS™ storage system generates its own internal heat as it is charging and discharging the batteries, thus allowing a very low operating temperature.

3) It is recommended to install a cold weather package on the generator and EBOSS™ to ensure smooth and reliable operation in extreme cold temperatures. An optional cold weather package for the EBOSS™ includes a 600W enclosure heater with built in thermostat. The ventilation cover should also be closed (from the inside) during operation below 32°F (0°C).

4) Exhaust fans mounted internally are thermally controlled and will turn on when internal temperatures reach 122°F (50°C) and above. During cold weather operations, the internal temperature should not reach 122°F (50°C). In the event of internal temperatures exceeding these limits during cold-weather operations, open the ventilation cover. The ventilation cover should remain in the open position when temperatures are above freezing to prevent overheat damage to the EBOSS™.



Ventilation Cover



Enclosure Heater



When temperatures are expected to be lower than -22°F (-30°C), it is recommended to keep the unit on and running with ventilation cover closed and enclosure heater plugged in. With these cold weather accessories installed, the EBOSS™ is rated for operation as low as -50°F (-45°C). A thermal blanket or cover may be installed over the EBOSS™ to allow for even colder temperatures.

▶ Cold Start Procedure

- 1)** The three inverters in the EBOSS™ are located in the front panel. They must be above 14°F (-10°C) to start up and begin operation. This could take several minutes or hours to heat up on its own so it is recommended plug in the optional enclosure heater or use an external heater to get the inverter and enclosure components warm enough to start.
- 2)** Once the generator starts, either the generator or an external power source can be used as a source to plug in the enclosure heater or external heat source. The enclosure heater is connected to a flush mount 120V plug located on the front panel and clearly labeled when a cold weather kit is ordered with the EBOSS™.
- 3)** The batteries must be above -22°F (-30°C) in order for the EBOSS™ to charge the batteries. An electric heating blanket or blowing warm air onto the battery tray under the EBOSS™ can get the batteries up to temperature. Once operational, it should provide enough heat to continue operation without external aids.

▶ Parallel Mode Operation

The EBOSS™ uses a simple method of paralleling, where no communication between units is required. The grid converter mimics the physical properties of a traditional load sharing generator, using frequency droop to share the load across all units via a common bus.

Ensure all EBOSS™ units in parallel are set to 480V through the “Adjust Voltage” button. The EBOSS™ can only parallel in 480V or 208V 3 phase. The system will not properly load share when paralleling 120V or 240V single phase loads, although all voltages are available for power distribution while in parallel.

▶ HMI (Human Machine Interface) Display

Overview of the HMI Display

The Home screen of the HMI allows the user to operate the EBOSS™. The start button is red when the unit is off with the description “Press to Start”. When the start button is pressed the color turns green with the description “Press to Stop”.

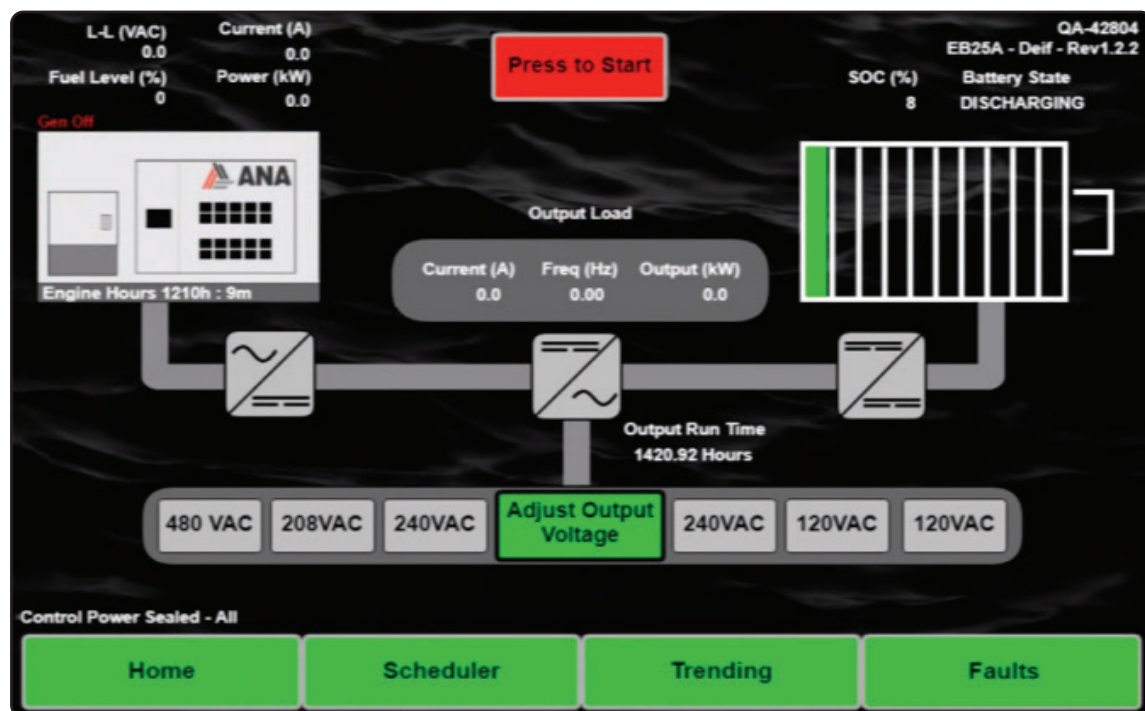

The top left of the screen above the generator shows, line voltage (VAC), current (A), fuel level (%) and power (kW) output of the generator. When the start button is pressed the generator status will display the following:

- Gen Off - before the start button is pressed.
- Gen Run Command - run command initiated to the generator.
- Gen Ready - generator is ready and going through startup.
- Gen Running - generator is online and providing power.

The top right above the battery shows general battery information such as state of charge (SOC) percentage and battery state. When the unit is operating the battery state will either say “charging” or “discharging.”

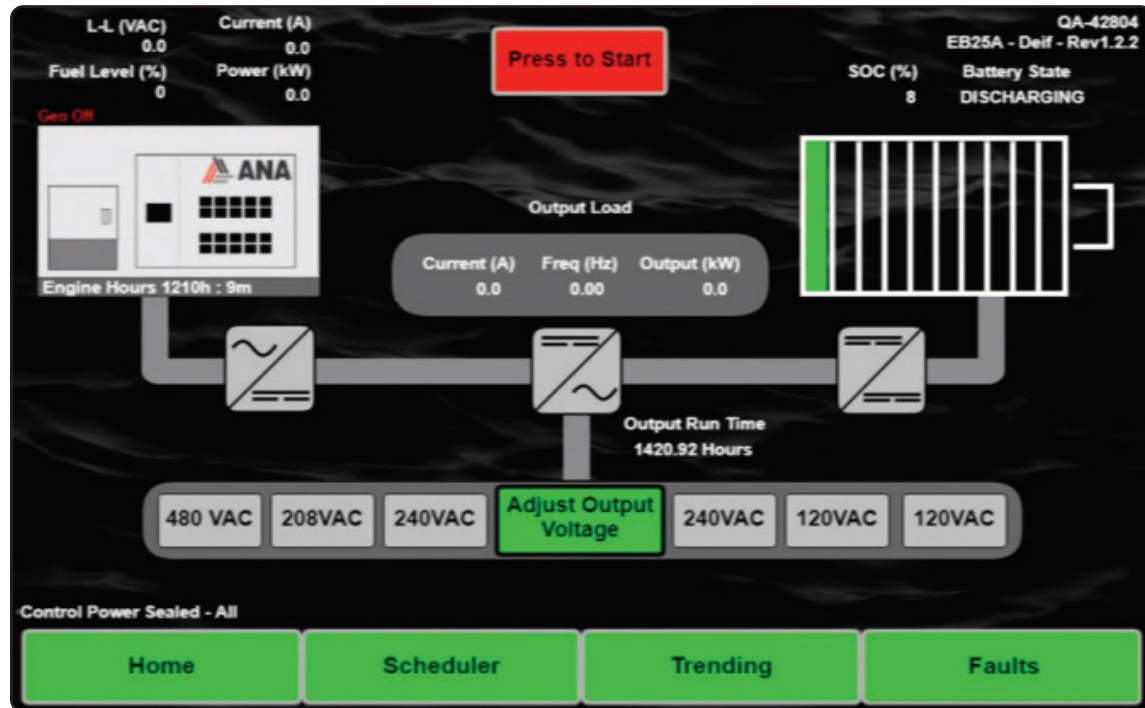

Notice the flow of power between all the major devices:

- Generator to AFE (AC)
- AFE to DC Bus
- DC Bus to DC/DC Inverter
- DC Bus to Grid Converter
- Grid Converter to Load (AC)

The flow of power will be either gray (off), green with animated arrows showing direction of power flow (on), or red (faulted). When a major device has faulted the bus associated with that device will be red and a red fault symbol appears. This fault symbol is clickable and will navigate to the fault screen in addition to the fault button on the navigation bar to identify and troubleshoot the issue.

EBOSS™ Supplying Power and Charging the Batteries

The screen below shows power from the generator going to the AFE inverter. AFE inverter is inverting this to the DC Bus. The DC/DC inverter is using the DC Bus to charge the batteries, and the grid converter is using the DC Bus to convert this to AC voltage to supply the load.

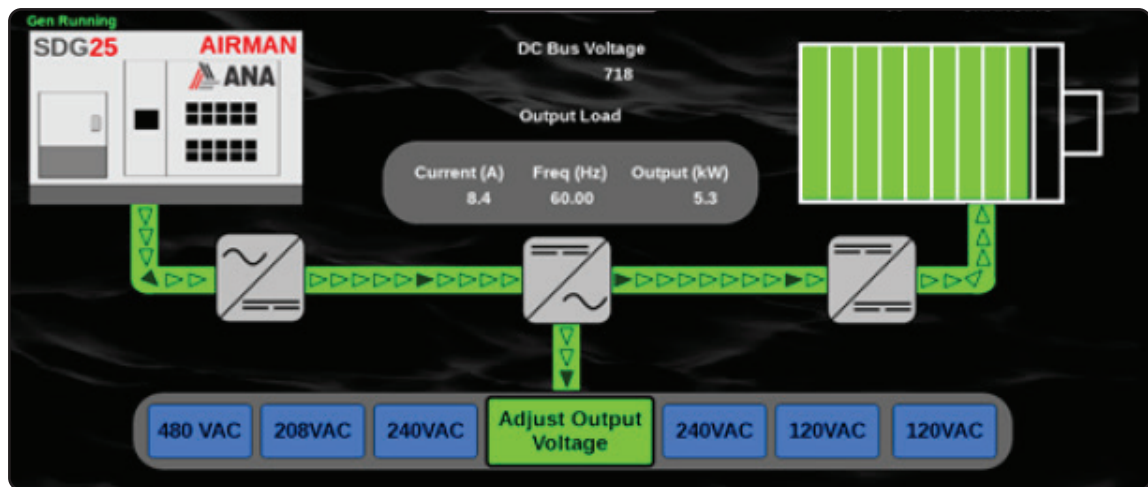

EBOSS™ Supplying Power with Generator Off

The screen below shows the generator off. The batteries are supplying power through the DC/DC inverter to the DC Bus. The grid converter continues to use the DC Bus to convert voltage to AC voltage to supply the load.

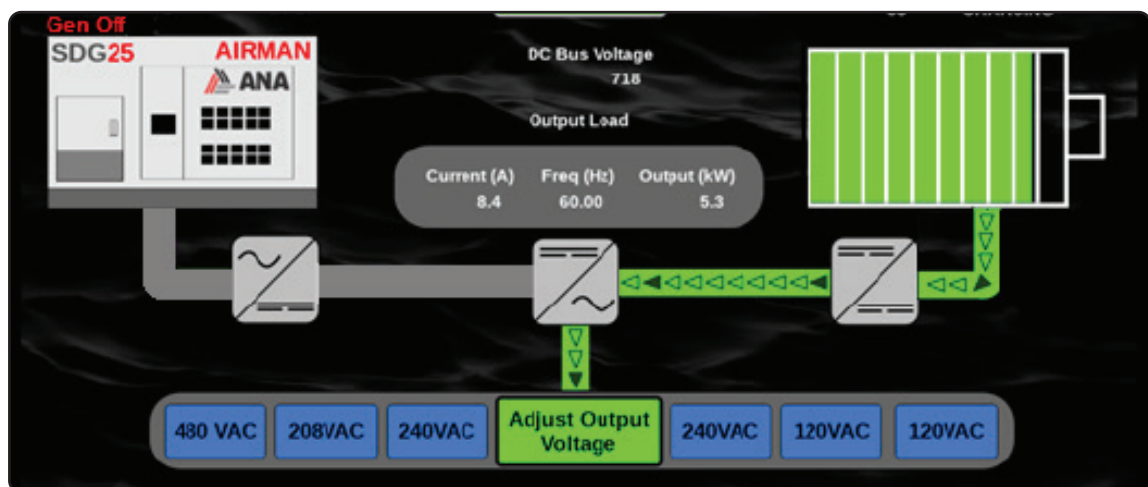

▶ Faults

When a failure occurs during operation of the EBOSS™, the HMI screen will display a red triangular fault symbol.



When any device fails on the unit, the unit will display a fault symbol which is selectable and will navigate to the faults screen. The user can also view existing faults by using the faults button on the navigation bar.

Faults can be viewed and reset via the HMI screen. Possible fault causes should be investigated by the user in an effort to prevent future faults from occurring. Please contact ANA technical support if repeated faults are experienced with your EBOSS™.

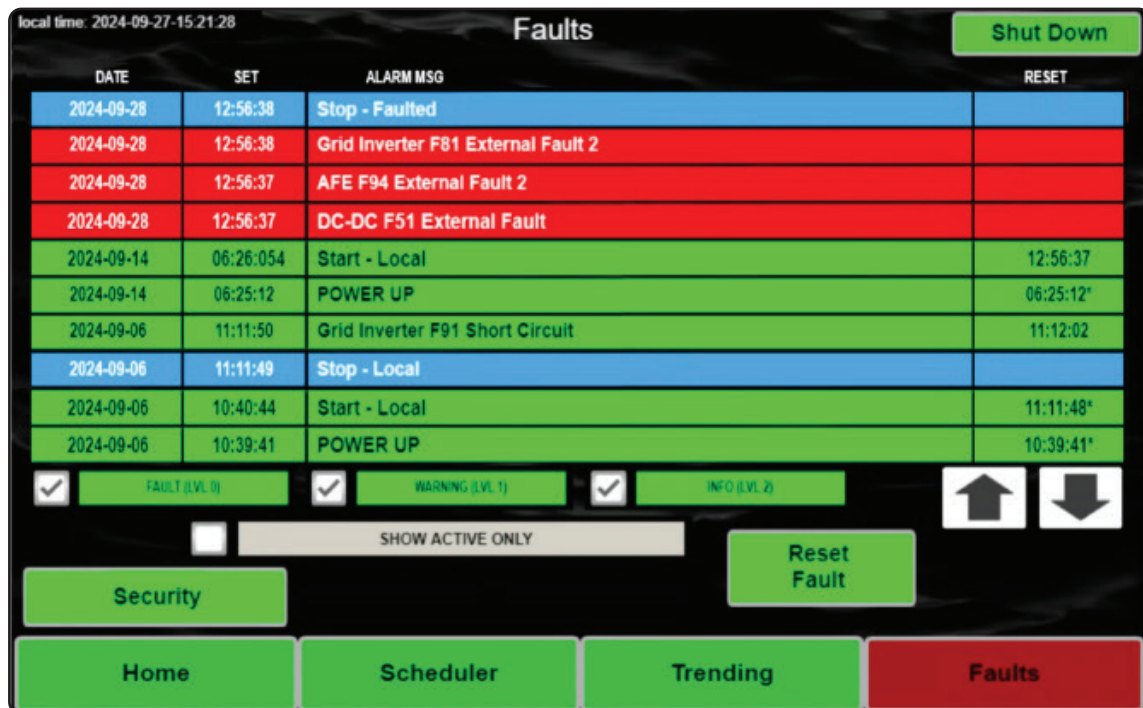

DATE	SET	ALARM MSG	RESET
2024-09-28	12:56:38	Stop - Faulted	
2024-09-28	12:56:38	Grid Inverter F81 External Fault 2	
2024-09-28	12:56:37	AFE F94 External Fault 2	
2024-09-28	12:56:37	DC-DC F51 External Fault	
2024-09-14	06:26:054	Start - Local	12:56:37
2024-09-14	06:25:12	POWER UP	06:25:12*
2024-09-06	11:11:50	Grid Inverter F91 Short Circuit	11:12:02
2024-09-06	11:11:49	Stop - Local	
2024-09-06	10:40:44	Start - Local	11:11:48*
2024-09-06	10:39:41	POWER UP	10:39:41*

local time: 2024-09-27-15:21:28

Shut Down

FAULT (LVL. 0) [checked] WARNING (LVL. 1) [checked] INFO (LVL. 2) [checked]

SHOW ACTIVE ONLY [checkbox]

Reset Fault

Security

Home Scheduler Trending **Faults**

► Trending Information

The trending screen will display a graph of information including: State of charge (SOC), Charge Current, Discharge Current, and Grid kilowatts (kW). This information is only displayed on the graph for the first 24hrs after starting the EBOSS™.

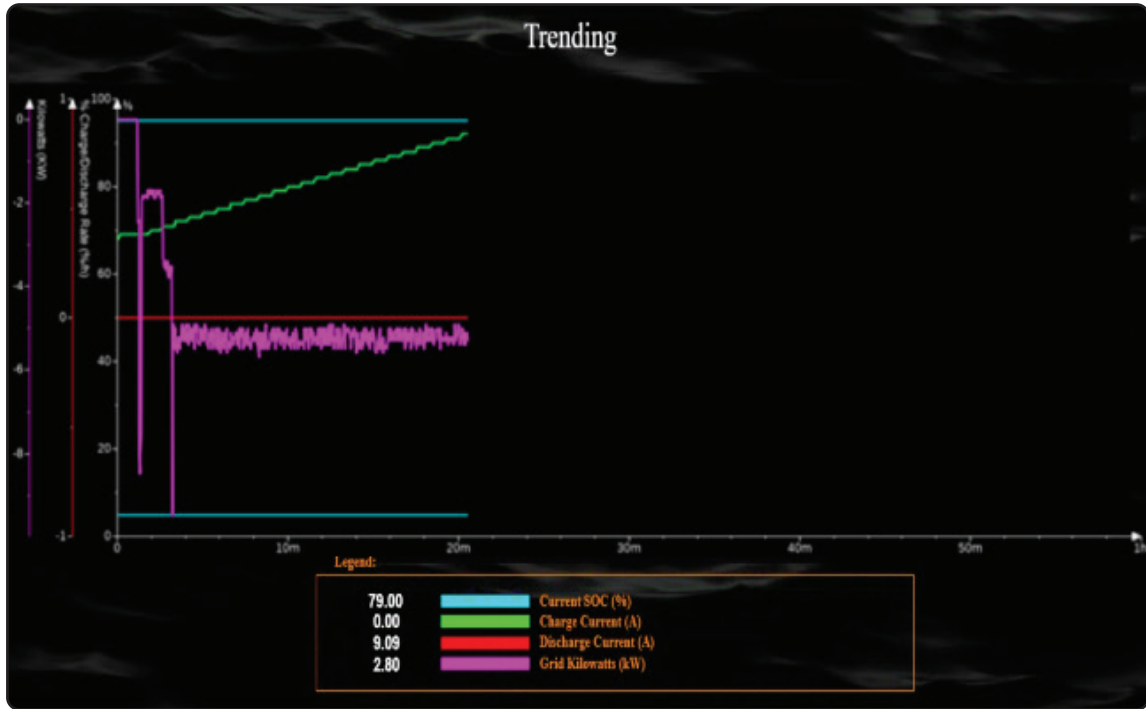

► Scheduler Operation

The Scheduler screen allows for 3 scheduled start charge times and multiple day selection. This is most commonly used for instances when operation solely on the batteries is required such as hosting an event or a generator maintenance. If the batteries reach a low state of charge the system will still command a charge cycle outside of the scheduled times.

The scheduler operation will call for the a charge cycle regardless of battery state of charge, and charge the batteries to 100% or the scheduler duration, whichever comes first.

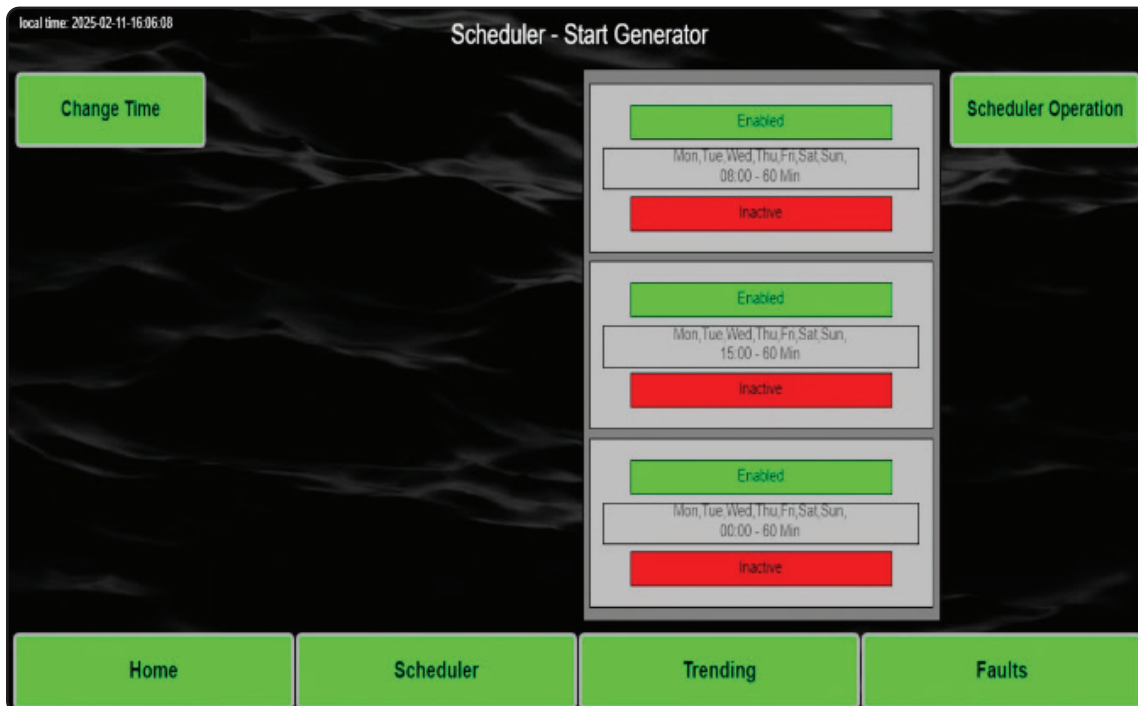

Please note the local time in the upper left corner and ensure its accuracy before enabling the scheduler. Adjust if necessary.

When a scheduler selection is enabled, the indicator will display as green and enabled. If the EBOSS™ is currently running a scheduled charge cycle, the red inactive indicator will change to green and display as active.

The home screen will display a blue icon indicating the scheduler has been set and enabled.

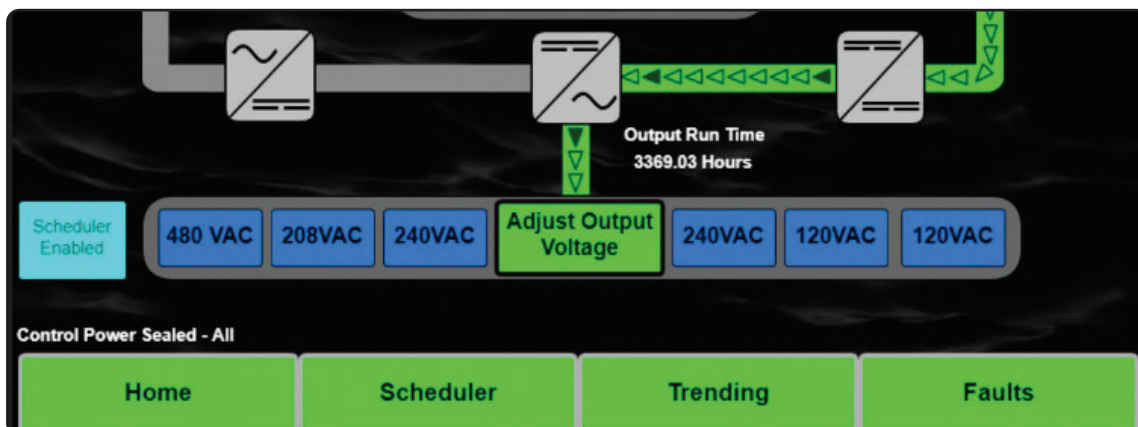

▶ Remote Monitoring

Telematics - Telematics is a system of software and hardware elements that allows:

- Control of industrial processes locally or at remote locations.
- Monitor, gather, and process real-time data.
- Directly interact with devices in a similar display as the human-machine interface (HMI) software.

From a single unit to an entire fleet, ANA's telematics enables remote access, diagnostics, and monitoring of the EBOSS™. This enables our service technicians to provide an enhanced level of service to your EBOSS™ units in the field.

Generator Status

Telematics is also able to review generator status. This is helpful in reviewing performance value history to determine the overall health and performance of the generator.

▶ Maintenance



This equipment should be serviced by qualified electrical maintenance personnel. Failure to observe this precaution could result in death or severe injury.

The EBOSS™ is generally mated to a standard Airman generator. All standard maintenance on the generator should be followed based off of the recommended service intervals as specified in the generator's user manual.



Completely turn off the EBOSS™ and generator and remove the service disconnect before performing any maintenance. Ensure the service disconnect is twisted off completely and placed away from the mating connector to avoid making any contact.

There are five fans in the EBOSS™ that should be dusted every 6 months (every 2-3 months in severe conditions). Three fans are mounted to the inverters (front side), the other two fans can be accessed via the street or curb side doors and are used to cool the transformers.

Compressed air should be used to remove dust and debris from the fans. Do not make contact between the can nozzles and the sensitive internal electronics of the EBOSS™, as damage can result.

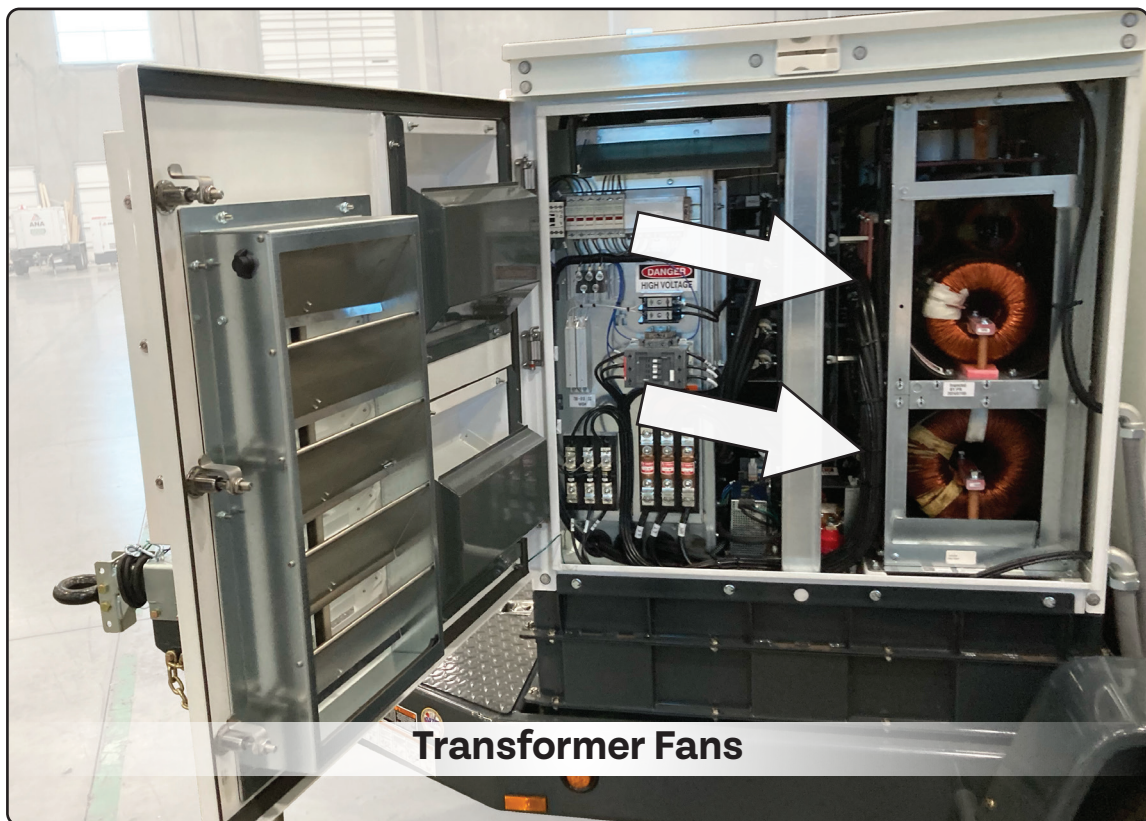



Inverter Fans

Compressed air should be used to remove dust and debris from the fans. Do not make contact between the can nozzles and the sensitive internal electronics of the EBOSS™, as damage can result.

► **Storage**

The internal battery storage system should be stored with 50% to full-charge while the unit is not in use for long periods. For storage over 1 month, the battery disconnect (orange cap, located inside at the base of the unit) may be removed to prevent any measurable battery drain. Disconnect the orange battery disconnect by twisting it counterclockwise and lift off completely.



This equipment should be serviced by qualified electrical maintenance personnel. Failure to observe this precaution could result in death or severe injury.



Battery Disconnect

The EBOSS™ is designed to be used outdoors. However, it is recommended that the unit is stored undercover when possible to prevent unnecessary weathering.

Make sure EBOSS™ is stored where there is no risk of flooding. Flood water inside of the unit, including the battery, is not covered under warranty.

► Warnings and Alarms

Please refer to your generator's manual for more information and description of the following warnings and alarms.

Warnings and Alarms		
Warning	Description	Solution
Battery Charging Request	The battery minimum cell voltage has reached 2.25VDC and is not in a running state.	Press start and let the batteries charge to full before shutting down.
Shutdown Timer Started	The battery minimum cell voltage has reached 2.20V and is not in a running state. A 30min timer is started when this is displayed, after 30min without a start signal the energy boss will turn off control power.	No action is needed, this timer will turn off control power to prevent over-discharge of the batteries.
Battery Low Limit	The battery minimum cell voltage has reached 2.07VDC. The DC-DC discharging limit is set to 0% until the string minimum cell voltage reaches 2.21V.	Decrease load to charge the batteries.
Control Power Jumper Installed	After 2 minutes of control power being jumped, this warning occurs. This will lead to the batteries being over-discharged if the unit is not running.	Verify wiring on the control power black button.

Warnings and Alarms		
Shutdown	Description	Solution
<p>Grid Inverter F81-External Fault 2</p> <p>DC-DC F51-External Fault</p> <p>AFE F94-External Fault 2</p>	<p>All 3 drives have the external fault contact activated. Emergency Stop button has been pressed.</p>	<ol style="list-style-type: none"> 1. Emergency Stop button has been pressed. 2. Pull Emergency Stop button out and reset the faults. 3. If these faults occur individually: <ol style="list-style-type: none"> a. Verify wiring on the Emergency Stop relays. b. Contact ANA Tech Support
<p>Magnetics Top Tube Overheated</p>	<p>There is temperature switch in the top tube of magnetics. The temperature switch opens at 75°C. Once the transformer is below 70°C then the temperature switch will close again.</p>	<ol style="list-style-type: none"> 1. Check fan operation. 2. Check wiring for loose connections. 3. Verify panel vents are not obstructed.
<p>CTM Transformer Overheated</p>	<p>There are 3 temperature switches wired in series on the transformer in the bottom tube of the magnetics. The temperature switches open at 130°C. Once the transformer is back below 125°C, then the temperature switch will close again.</p>	<ol style="list-style-type: none"> 1. Check fan operation. 2. Check wiring for loose connections. 3. Verify panel vents are not obstructed.

Warnings and Alarms		
Shutdown	Description	Solution
Surge Arrestor Blown	A voltage spike has caused the surge arrestor to open.	<ol style="list-style-type: none"> 1. Check the indicator on the surge arrestor to verify if it has blown. Replace surge arrestor. 2. Verify auxiliary wiring on surge arrestor is secure. 3. Verify surge arrestors are secure and have not vibrated loose.
Grid Inverter F1-Over Current	The Grid Inverter has detected a high current output greater than it is capable of.	<ol style="list-style-type: none"> 1. Sudden increase in load or overload. <ol style="list-style-type: none"> a. Check load. 2. Short circuit in load cables. <ol style="list-style-type: none"> a. Check cables.
Grid Inverter F91-Short Circuit	Drive has operated against current limit for more than the short circuit time allowed. A fault comes after the short circuit timer, typically 3-4 seconds.	<ol style="list-style-type: none"> 1. Sudden increase in load or overload. <ol style="list-style-type: none"> a. Check load. 2. Short circuit in load cables. <ol style="list-style-type: none"> a. Check cables.

Warnings and Alarms		
Shutdown	Description	Solution
AFE F92-Supply Voltage	The AFE supply voltage is outside of allowable parameters.	<ol style="list-style-type: none"> 1. Verify the generator is producing 480VAC. 2. Verify the main breaker on the generator is closed. 3. Check input supply fuses (bottom left set).
AFE F10-Line Synchronization Fault	The AFE did not sync to the generator voltage within the time period allowed.	<ol style="list-style-type: none"> 1. Verify the generator is producing 480VAC. 2. Verify the main breaker on the generator is closed. 3. Check input supply fuses (bottom left set).
AFE Precharge Error	The AFE did not come out of precharge. The DC bus voltage needs to be higher than 625VDC to get out of precharge.	<ol style="list-style-type: none"> 1. Verify the generator is producing 480VAC. 2. Verify the main breaker on the generator is closed. 3. Check input supply fuses (bottom left set). 3. Verify precharge contactor is closing. 4. Check precharge fuses (top left set). 5. Contact ANA Tech Support.

Warnings and Alarms		
Shutdown	Description	Solution
Generator Communication Fault	The HMI cannot communicate with the generator.	<ol style="list-style-type: none"> 1. Verify the control power switch for the generator is powered "ON". 2. Verify the serial connector is securely plugged into the back of the HMI. 3. Verify the RS485 connector is plugged into the back of the Deep Sea generator controller. 4. Verify the 120ohm resistor is across pins 57 and 58 on the RS485 connector on the Deep Sea.
Generator Timeout Fault	The generator does not return 'ready' within 2 minutes of a start command being sent or the generator is faulted when the command is issued for start.	<ol style="list-style-type: none"> 1. Verify generator controller is ON and in Auto. 2. Verify no warnings or shutdown codes are present on the generator. 3. Verify communication to the generator

Warnings and Alarms		
Shutdown	Description	Solution
Battery System BMU CMU Fault	The Battery Management Unit has received an abnormal response from the batteries.	<ol style="list-style-type: none"> 1. Possible over-discharge, dead batteries/cells or temperature issues. 2. Communication issues between the BMU and the batteries. 3. Call ANA Tech Support to continue diagnosis.

Technical Support

Any servicing, diagnostics, or repairs should only be performed by trained personnel equipped with the proper tools and safety equipment. Please contact our technical support team for further information or to assist with repairs.

ANA Technical Support
 Phone: 1-562-450-3570
 Email: support@anacorp.com
anacorp.com

► Troubleshooting

The following chart lists potential issues, their causes, and solutions. If you are unable to resolve your issue, please contact our service department and they can assist you.

Warning - Hazardous High Voltage



This equipment should be installed, adjusted, and serviced by qualified electrical maintenance personnel familiar with the construction and operation of this type of equipment and the hazards involved. Failure to observe this precaution could result in death or severe injury.

Troubleshooting Chart		
Issue	Possible Cause(s)	Suggestion
Unit is on but there is no output power.	The output circuit breaker may not be switched on.	Check that the circuit breaker is pushed up to the on position.
	Proper startup procedure not followed.	Refer to the beginning of the manual for proper startup procedure
	Emergency Stop may be activated.	De-activate the emergency stop.
	There may be active faults.	Navigate to the faults page for further information

Troubleshooting Chart		
Issue	Possible Cause(s)	Suggestion
The system power has been switched on but there is no display on HMI screen.	The display may have entered sleep mode.	Tap the screen to wake from sleep mode.
	The battery pack voltage may be too low.	Contact ANA technical support.
There is power being sent to the EBOSS™, but it is not charging.	The AC input Fuses may be disconnected or blown.	Check the AC input fuses, connect or replace if necessary.
	Incorrect generator voltage.	Verify generator output voltage is between 480-490VAC, and generator main breaker is closed.
Output voltage is lower than desired voltage over distance.	If the distance between the unit and the load is more than 50 meters, the voltage can drop too low.	Press “Adjust Voltage” and adjust as needed.
SoC reading 0% and not allowing output.	This indicates that the battery pack voltage has reached its lower limit and has turned off its output to protect the batteries.	Open load output breakers, follow startup procedure and allow battery SOC to increase before applying load.
Output circuit breaker continually trips.	The load being connected draws too much power for the rated output of the unit.	Refer to the maximum output rating on the unit’s rating plate and reduce the total power draw accordingly.

Troubleshooting		
Issue	Possible Cause(s)	Suggestion
AFE input power fuses continually blow	Generator to EBOSS™ cables damaged or loose	Verify cable integrity and check connections on the back of the generator output lug panel. Replace blown fuses if necessary.
	Internal short circuit within the EBOSS™.	Contact ANA technical support.
Remote Generator Start not working.	Start signal not being sent.	Verify home screen displays “Generator Run Command” above the generator.
	Generator is in manual mode.	Verify generator controller is placed in AUTO mode.
	Faulty Moxa device, not closing A1-A2 for remote start	Contact Technical Support.
	Loose or damaged A1-A2 remote start wires.	Verify integrity of A1-A2 remote start wires.
Diesel generator constantly running.	Generator running in manual mode.	Verify generator controller is placed in AUTO mode.
	High loads will require more frequent charge cycles.	Reduce the load.

▶ **Warranty Information**

See the printed warranty statement included with your EBOSS™ for current warranty information.

▶ **Notice - Please Read**

The product discussed in this literature is subject to terms and conditions outlined in the selling policies of Alliance North America (ANA, Inc.). The sole source governing the rights and remedies of any purchaser of this equipment is the relevant selling policy of ANA Inc.

NO WARRANTIES, EXPRESS OR IMPLIED, INCLUDING WARRANTIES OF FITNESS FOR A PARTICULAR PURPOSE OR MERCHANTABILITY, OR WARRANTIES ARISING FROM COURSE OF DEALING OR USAGE OF TRADE, ARE MADE REGARDING THE INFORMATION, RECOMMENDATIONS AND DESCRIPTIONS CONTAINED HEREIN.

In no event will ANA be responsible to the purchaser or user in contract, in tort (including negligence), strict liability or otherwise for any special, indirect, incidental or consequential damage or loss whatsoever, including but not limited to damage or loss of use of equipment, plant or power system, cost of capital, loss of power, additional expenses in the use of existing power facilities, or claims against the purchaser or user by its customers resulting from the use of the information, recommendations and descriptions contained herein.

Please note, the information contained in this manual is subject to change without notice.

ANA, Inc.
1770 Raiders Way
Henderson, NV 89052
anacorp.com

Sales and Support
Phone: 1-562-450-3570
Email: support@anacorp.com
Email: sales@anacorp.com

Page Intentionally Left Blank



ANA
ENERGY

HYBRID ENERGY SYSTEM

EBOSS™
70kVA
- HYBRID SYSTEM -

Operation Manual